

SERVICE MANUAL

INTEGRATED COLOR TV / STEREO VIDEO
CASSETTE RECORDER

BASIC TAPE MECHANISM : OVD-6

SPECIFICATIONS

GENERAL

POWER REQUIREMENTS	120V AC, 60Hz
POWER CONSUMPTION	89W
	TYP 4W (power save mode)
WEIGHT	13.5 kg (29.8 lbs.)
DIMENSIONS	435 mm (W) x 370.5 mm (D) x
	384.5 mm (H)
	(17 1/4 x 14 5/8 x
	15 1/4 in.)

TV SECTION

PICTURE TUBE	208 mm (W) x 211 mm (H)
	(8 1/4 x 8 3/8 in.)
	335 mm (diagonal) (13 in.)
TUNER SYSTEM	Frequency synthesized tuner
CHANNEL COVERAGE	VHF: 2 to 13
	UHF: 14 to 69
	CATV: 5A, A-1 to A-5, A to W,
	W+1 to W+84

PROGRAM MEMORY	181
TV SYSTEM	M
HORIZONTAL RESOLUTION	230 lines
ANTENNA INPUT	75 ohms, unbalanced

VCR SECTION

OPERATING TEMPERATURE	5°C to 40°C
VIDEO RECORDING SYSTEM	Rotary 2 head helical scanning system

VIDEO SIGNAL SYSTEM	NTSC color system, 525 lines, 60 fields
VIDEO HEAD	Azimuth 2 head
USABLE CASSETTES	VHS video cassette
	S-VHS video cassette (play back only)
TAPE SPEED	SP: 33.35 mm/sec
	LP: 16.67 mm/sec
	SLP: 11.12 mm/sec
RECORDING/PLAYBACK TIME	SP: 3 hours with T-180 tape
	LP: 6 hours with T-180 tape
	SLP: 9 hours with T-180 tape
VIDEO INPUT	1.0Vp-p, 75 ohm, unbalanced
VIDEO OUTPUT	1.0Vp-p, 75 ohm, unbalanced
VIDEO S/N	53dB (nominal)
AUDIO INPUT	-8dBs, 50K ohm
AUDIO OUTPUT	-8dBs, less than 1K ohm
AUDIO TRACK	1 tracks (Normal sound)
FAST-FORWARD TIME	Approx. 2 minutes 15 seconds with T-120 tape
REWIND TIME	Approx. 1 minute 48 seconds with T-120 tape

● Design and specifications are subject to change without notice.

TABLE OF CONTENTS

SPECIFICATIONS	COVER
TABLE OF CONTENTS	A1-1
SERVICING NOTICES ON CHECKING	A2-1
DISASSEMBLY INSTRUCTIONS	
REMOVAL OF MECHANICAL PARTS AND P.C. BOARDS	B1-1, B1-2
REMOVAL OF DECK PARTS	B2-1~B2-5
REMOVAL OF ANODE CAP	B3-1
KEY TO ABBREVIATIONS	C1-1, C1-2
SERVICE MODE LIST	C2-1
PREVENTIVE CHECKS AND SERVICE INTERVALS	C3-1, C3-2
NOTE FOR THE REPLACING OF MEMORY IC	C4-1
SERVICING FIXTURES AND TOOLS	C5-1
PREPARATION FOR SERVICING	C5-2, C5-3
VCR TEST TAPE INTERCHANGEABILITY TABLE	C6-1
MECHANICAL ADJUSTMENTS	
CONFIRMATION AND ADJUSTMENT	D1-1, D1-2
CONFIRMATION AND ADJUSTMENT OF TAPE RUNNING MECHANISM	D1-2, D1-3
MECHANISM ADJUSTMENT PARTS LOCATION GUIDE	D1-4
ELECTRICAL ADJUSTMENTS	
ADJUSTMENT PROCEDURE	D2-1
BASIC ADJUSTMENTS	D2-1~D2-4
ELECTRICAL ADJUSTMENT PARTS LOCATION GUIDE	D2-5, D2-6
PURITY AND CONVERGENCE ADJUSTMENTS	D2-7
TROUBLESHOOTING GUIDES	E-1~E-26
IC DESCRIPTIONS	F1-1~F1-3
SERVO TIMING CHART	F2-1
SYSTEM SWITCH MODE	F2-2
SEMICONDUCTOR BASE CONNECTIONS	G-1
BLOCK DIAGRAMS	
TV	H-1
Y/C/AUDIO/HEAD AMP/IN/OUT	H-2
MICON/POWER/OPERATION	H-3
PRINTED CIRCUIT BOARDS (OPERATION/DECK)	I-1
OPERATION SCHEMATIC DIAGRAM	I-2
DECK SCHEMATIC DIAGRAM	I-3
PRINTED CIRCUIT BOARDS (SYSCON)	I-4~I-6
Y/C/AUDIO/HEAD AMP SCHEMATIC DIAGRAM	I-7
MICON SCHEMATIC DIAGRAM	I-8
CHROMA/IF SCHEMATIC DIAGRAM	I-9
IN/OUT SCHEMATIC DIAGRAM	I-10
POWER SCHEMATIC DIAGRAM	I-11
SOUND AMP SCHEMATIC DIAGRAM	I-12
PRINTED CIRCUIT BOARDS (MAIN/CRT)	I-13
DEFLECTION SCHEMATIC DIAGRAM	I-14
TV POWER SCHEMATIC DIAGRAM	I-15
CRT SCHEMATIC DIAGRAM	I-16
INTERCONNECTION DIAGRAM	I-17
WAVEFORMS	J-1~J-3
MECHANICAL EXPLODED VIEW	K1-1, K1-2
MECHANICAL REPLACEMENT PARTS LIST	K1-3
ACCESSORY REPLACEMENT PARTS LIST	K1-3
CHASSIS EXPLODED VIEW (TOP VIEW)	K2-1
CHASSIS EXPLODED VIEW (BOTTOM VIEW)	K2-2
CHASSIS REPLACEMENT PARTS LIST	K2-3
ELECTRICAL REPLACEMENT PARTS LIST	K3-1~K3-4

SERVICING NOTICES ON CHECKING

1. KEEP THE NOTICES

As for the places which need special attentions, they are indicated with the labels or seals on the cabinet, chassis and parts. Make sure to keep the indications and notices in the operation manual.

2. AVOID AN ELECTRIC SHOCK

There is a high voltage part inside. Avoid an electric shock while the electric current is flowing.

3. USE THE DESIGNATED PARTS

The parts in this equipment have the specific characters of incombustibility and withstand voltage for safety. Therefore, the part which is replaced should be used the part which has the same character. Especially as to the important parts for safety which is indicated in the circuit diagram or the table of parts as a \triangle mark, the designated parts must be used.

4. PUT PARTS AND WIRES IN THE ORIGINAL POSITION AFTER ASSEMBLING OR WIRING

There are parts which use the insulation material such as a tube or tape for safety, or which are assembled in the condition that these do not contact with the printed board. The inside wiring is designed not to get closer to the pyrogenic parts and high voltage parts. Therefore, put these parts in the original positions.

5. TAKE CARE TO DEAL WITH THE CATHODE-RAY TUBE

In the condition that an explosion-proof cathode-ray tube is set in this equipment, safety is secured against implosion. However, when removing it or serving from backward, it is dangerous to give a shock. Take enough care to deal with it.

6. AVOID AN X-RAY

Safety is secured against an X-ray by considering about the cathode-ray tube and the high voltage peripheral circuit, etc.

Therefore, when repairing the high voltage peripheral circuit, use the designated parts and make sure not modify the circuit.

Repairing except indicates causes rising of high voltage, and it emits an X-ray from the cathode-ray tube.

7. PERFORM A SAFETY CHECK AFTER SERVICING

Confirm that the screws, parts and wiring which were removed in order to service are put in the original positions, or whether there are the portions which are deteriorated around the serviced places serviced or not. Check the insulation between the antenna terminal or external metal and the AC cord plug blades. And be sure the safety of that.

(INSULATION CHECK PROCEDURE)

1. Unplug the plug from the AC outlet.
2. Remove the antenna terminal on TV and turn on the TV.
3. Insulation resistance between the cord plug terminals and the external exposure metal **[Note 2]** should be more than 1M ohm by using the 500V insulation resistance meter **[Note 1]**.
4. If the insulation resistance is less than 1M ohm, the inspection repair should be required.

[Note 1]

If you have not the 500V insulation resistance meter, use a Tester.

[Note 2]

External exposure metal: Antenna terminal
Earphone jack

DISASSEMBLY INSTRUCTIONS

1. REMOVAL OF MECHANICAL PARTS AND P.C. BOARDS

1-1: BACK CABINET (Refer to Fig. 1-1)

1. Remove the 2 screws ①.
2. Remove the 2 screws ②.
3. Remove the 2 screws ③ which are used for holding the Back Cabinet.
4. Remove the AC cord from the AC cord hook ④.
5. Remove the Back Cabinet in the direction of arrow.

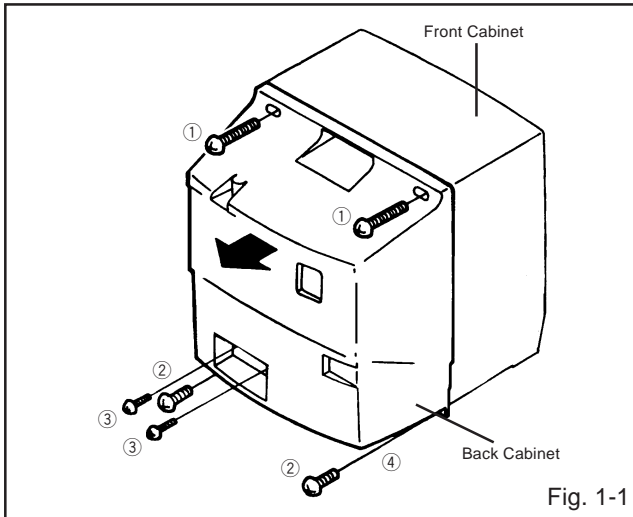

Fig. 1-1

1-2: CRT PCB (Refer to Fig. 1-2)

CAUTION: BEFORE REMOVING THE ANODE CAP, DISCHARGE ELECTRICITY BECAUSE IT CONTAINS HIGH VOLTAGE. BEFORE ATTEMPTING TO REMOVE OR REPAIR ANY PCB, UNPLUG THE POWER CORD FROM THE AC SOURCE.

1. Remove the Anode Cap.
(Refer to REMOVAL OF ANODE CAP)
2. Disconnect the following connectors:
(CP801, CP802 and CP850).
3. Remove the CRT PCB in the direction of arrow.

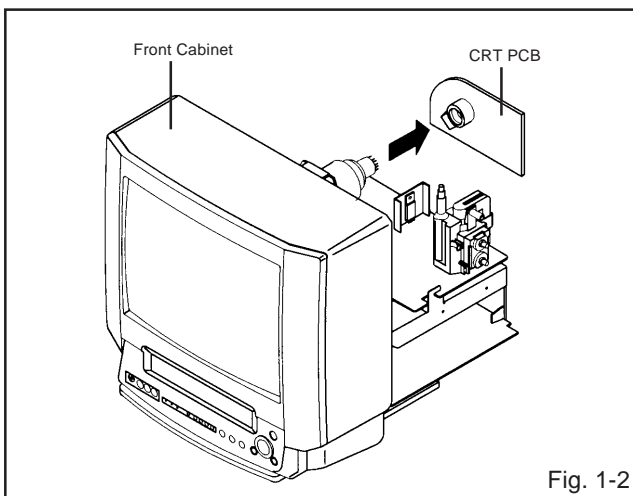

Fig. 1-2

1-3: TV/VCR BLOCK (Refer to Fig. 1-3)

1. Remove the 2 screws ①.
2. Disconnect the following connectors:
(CP351, CP352, CP353, CP354, CP401 and CP502).
3. Unlock the support ②.
4. Remove the TV/VCR Block in the direction of arrow.

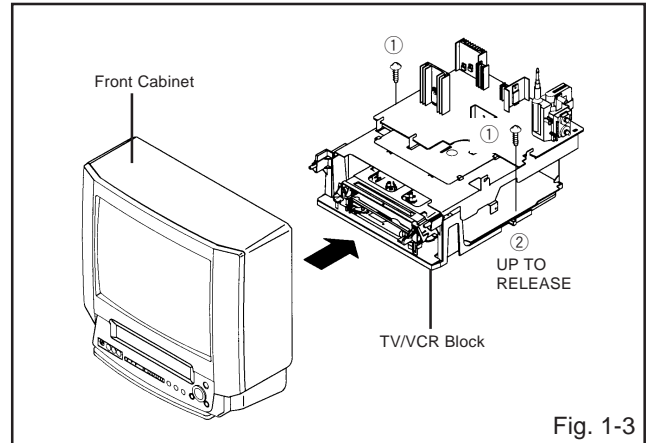

Fig. 1-3

1-4: MAIN PCB (Refer to Fig. 1-4)

1. Remove the screw ①.
2. Remove the Main PCB Holder.
3. Remove the 2 screws ②.
4. Remove the 3 screws ③.
5. Disconnect the following connectors:
(CP810, CP820, CP811 and CP804).
6. Remove the Main PCB in the direction of arrow.

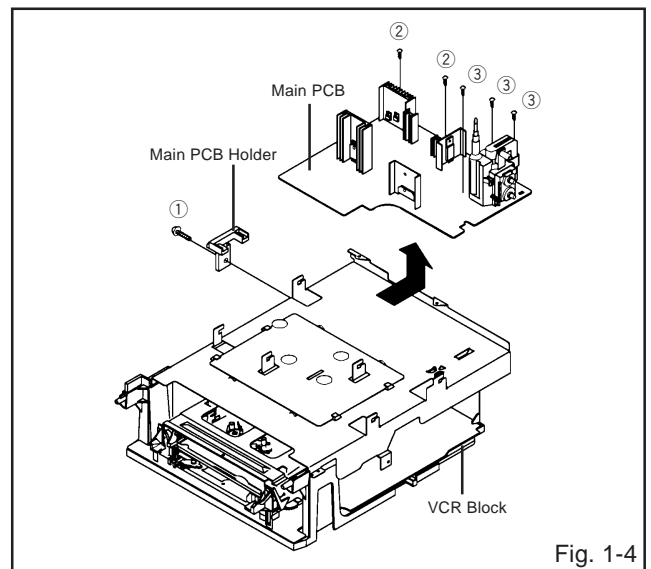
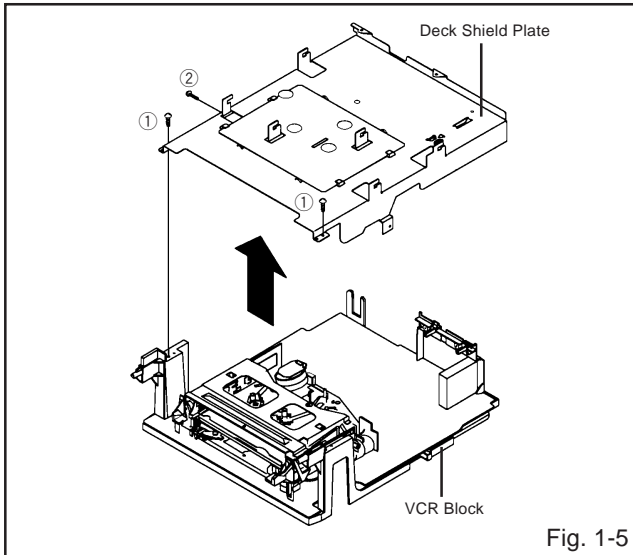

Fig. 1-4

DISASSEMBLY INSTRUCTIONS

1-5: DECK SHIELD PLATE (Refer to Fig. 1-5)

1. Remove the 2 screws ①.
2. Remove the screw ②.
3. Remove the Deck Shield Plate in the direction of arrow.



1-6: DECK CHASSIS (Refer to Fig. 1-6)

1. Remove the 3 screws ①.
2. Disconnect the following connectors:
(CP1002, CP1005, CP1006, CP4001, CP4004 and CP4005).
3. Remove the Deck Chassis in the direction of arrow.

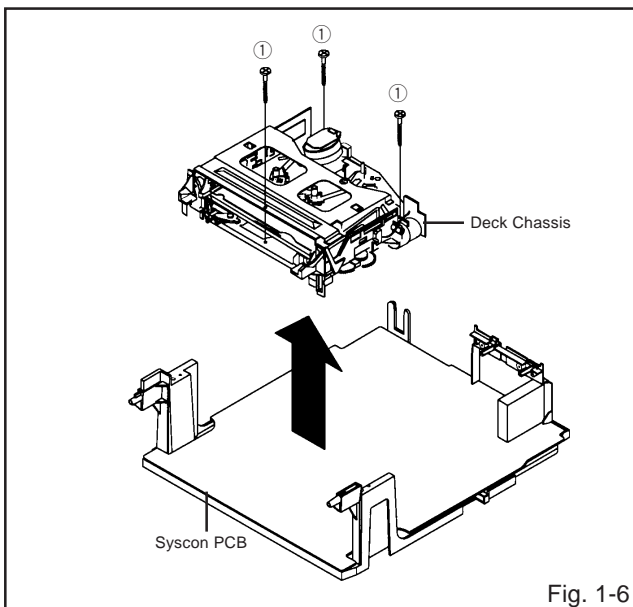

1-7: JACK PLATE AND SYSCON PCB (Refer to Fig. 1-7)

1. Remove the screw ①.
2. Remove the Syscon PCB in the direction of arrow (A).
3. Remove the screw ②.
4. Remove the nut ③.
5. Remove the washer ④.
6. Unlock the 2 supports ⑤.
7. Remove the Jack Plate in the direction of arrow (B).

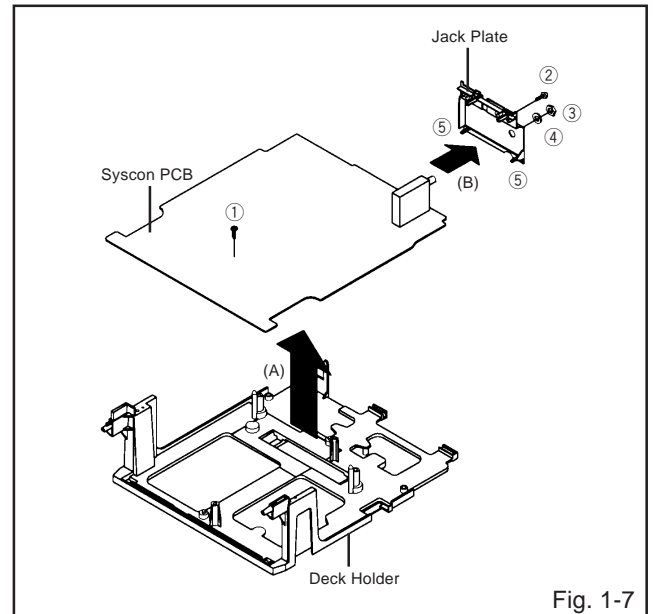

DISASSEMBLY INSTRUCTIONS

2. REMOVAL OF DECK PARTS

2-1: TOP BRACKET (Refer to Fig. 2-1)

1. Remove the 2 screws ①.
2. Slide the 2 supports ② and remove the Top Bracket.

NOTE

When you install the Top Bracket, install the screw (1) first, then install the screw (2).

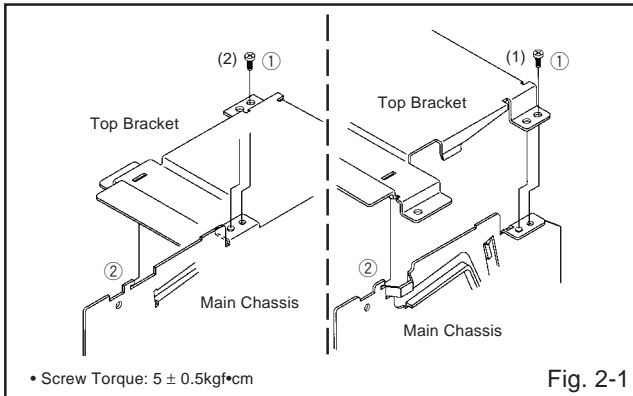

Fig. 2-1

2-2: FLAP LEVER/TAPE GUIDE R (Refer to Fig. 2-2)

1. Move the Cassette Holder Ass'y to the back side.
2. Remove the Polyslider Washer ①.
3. Remove the Flap Lever.
4. Unlock the 3 supports ② and remove the Tape Guide R.

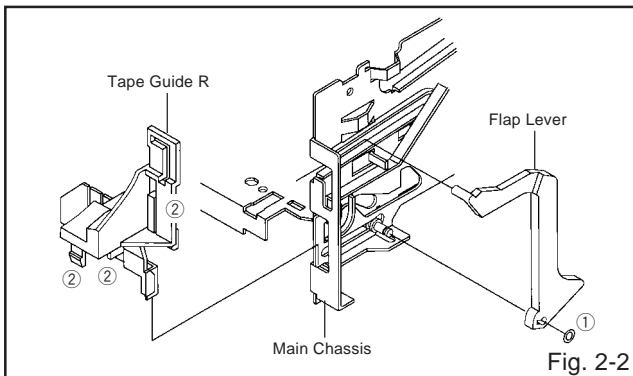

Fig. 2-2

2-3: TAPE GUIDE L (Refer to Fig. 2-3-A)

1. Move the Cassette Holder Ass'y to the back side.
2. Unlock the 2 supports ① and remove the Tape Guide L.
3. Remove the REC Lever. (Recorder only)

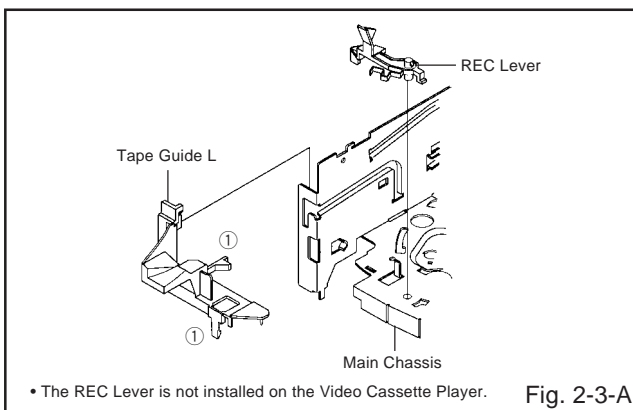

Fig. 2-3-A

NOTE

When you install the Tape Guide L, install as shown in the circle of Fig. 2-3-B. (Refer to Fig. 2-3-B)

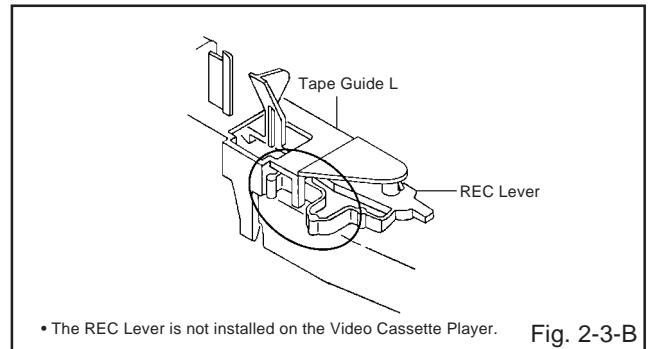

Fig. 2-3-B

2-4: CASSETTE HOLDER ASS'Y (Refer to Fig. 2-4)

1. Move the Cassette Holder Ass'y to the front side.
2. Push the Locker R to remove the Cassette Side R.
3. Remove the Cassette Side L.

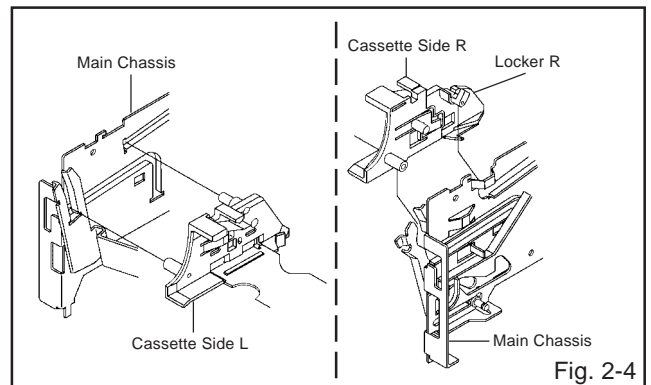

Fig. 2-4

2-5: CASSETTE SIDE L/R (Refer to Fig. 2-5)

1. Remove the Locker Spring.
2. Unlock the 4 supports ① and then remove the Cassette Side L/R.

NOTE

When you install the Cassette Side L/R, be sure to move the Locker L/R after installing.

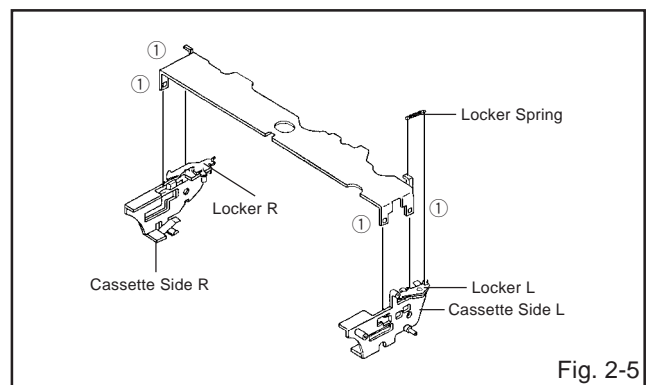
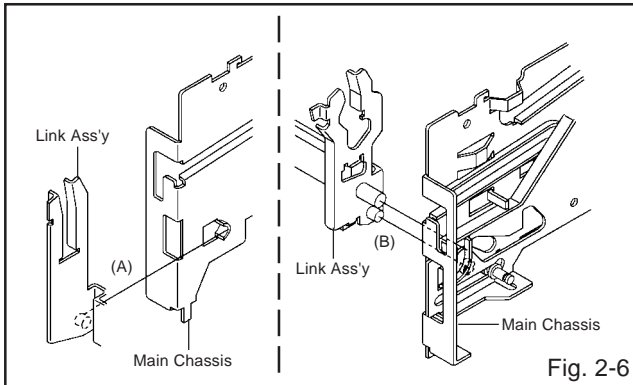

Fig. 2-5

DISASSEMBLY INSTRUCTIONS

2-6: LINK ASS'Y (Refer to Fig. 2-6)

1. Set the Link Ass'y to the Eject position.
2. Remove the (A) side of the Link Ass'y first, then remove the (B) side.



2-7: LOADING MOTOR ASS'Y (Refer to Fig. 2-7)

1. Remove the Link Lever.
2. Remove the Dumper Spring.
3. Remove the 2 screws ①.
4. Unlock the support ② and remove the Loading Motor Ass'y.
5. Unlock the 2 supports ③ and remove the Deck PCB (BOT).

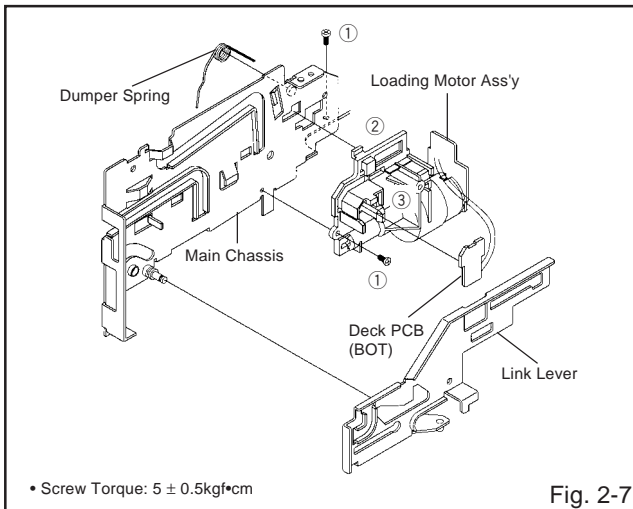

2-8: SENSOR COVER L (Refer to Fig. 2-8)

1. Unlock the support ① and remove the Sensor Cover L.
2. Unlock the 2 supports ② and remove the Deck PCB (EOT).

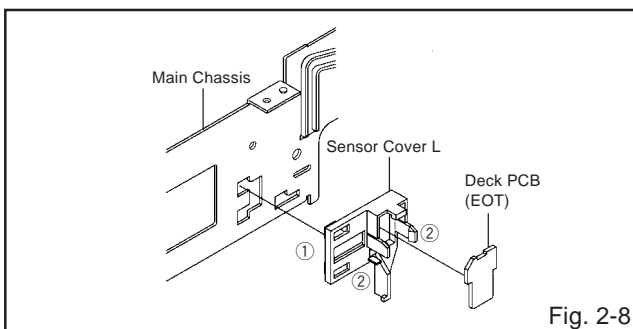

2-9: TENSION ASS'Y (Refer to Fig. 2-9-A)

1. Move the Inclined S Ass'y to the back side.
2. Unlock the support ① and remove the S Reel Stopper.
3. Remove the Tension Spring.
4. Unlock the support ② and remove the Tension Arm Ass'y.
5. Remove the Tension Adjust.
6. Unlock the 2 supports ③ and remove the Tension Band Ass'y.
7. Unlock the support ④ and remove the Tension Holder.

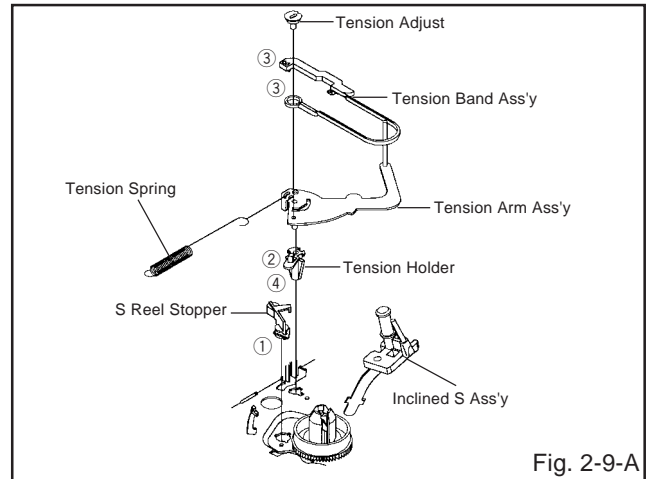

NOTE

When you install the Tension Adjust, install as shown in Fig. 2-9-B. (Refer to Fig. 2-9-B)

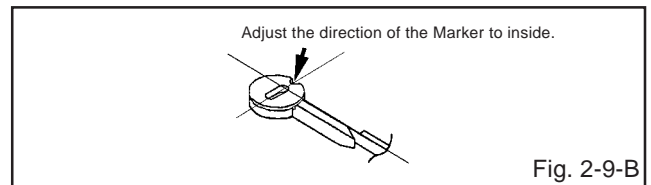

2-10: T BRAKE ASS'Y (Refer to Fig. 2-10)

1. Remove the T Brake Spring.
2. Remove the T Brake Ass'y.

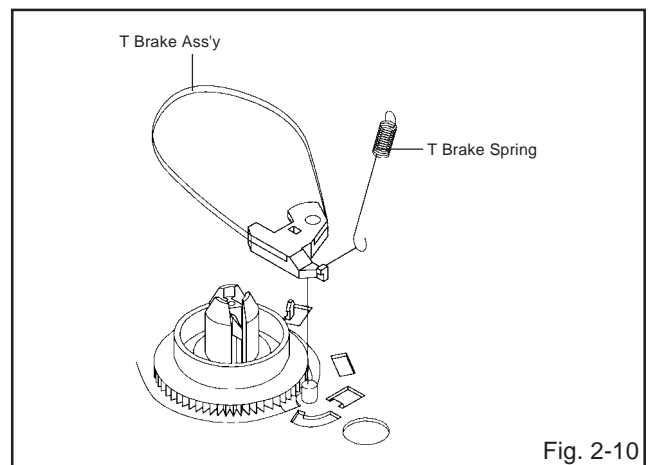

DISASSEMBLY INSTRUCTIONS

2-11: S REEL/T REEL ASS'Y (Refer to Fig. 2-11)

1. Remove the Idler Ass'y.
2. Remove the S Reel and T Reel Ass'y.
3. Remove the 2 Polyslider Washers ①.

NOTE

1. Take care not to damage the gears of the S Reel, T Reel Ass'y and Idler Ass'y.
2. The Polyslider Washer may be remained on the back of the reel.
3. Take care not to damage the shaft.
4. Do not touch the section "A" of S Reel and T Reel Ass'y. (Use gloves.) **(Refer to Fig. 2-11)** Do not adhere the stains on it.
5. When you install the reel, clean the shaft and oil it (KYODO OIL Slidas #150). (If you do not oil, noise may be heard in FF/REW mode.)
6. After installing the reel, adjust the height of the reel. **(Refer to MECHANICAL ADJUSTMENT)**

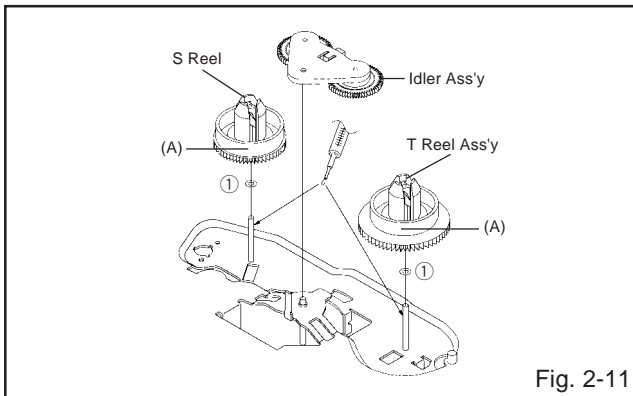

Fig. 2-11

2-12: PINCH ROLLER ASS'Y/P5 ARM ASS'Y (Refer to Fig. 2-12-A)

1. Remove the P5 Spring.
2. Remove the screw ①.
3. Unlock the 2 supports ② and remove the Cassette Opener.
4. Remove the Pinch Roller Ass'y, Pinch Roller Lever and P5 Arm Ass'y.

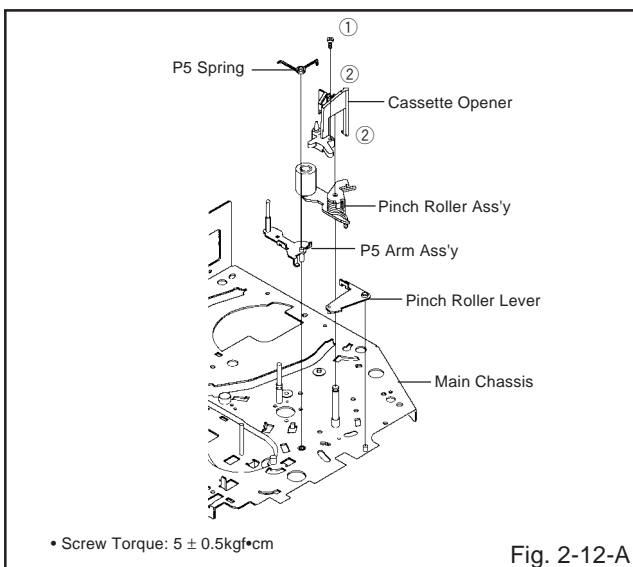

Fig. 2-12-A

NOTE

1. Do not touch the Pinch Roller. (Use gloves.)
2. When you install the Pinch Roller Ass'y, install as shown in the circle. **(Refer to Fig. 2-12-B)**

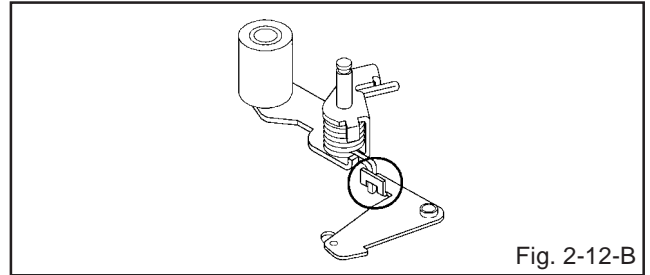

Fig. 2-12-B

2-13: A/C HEAD (Refer to Fig. 2-13-A)

1. Remove the screw ①.
2. Remove the A/C Head Base.
3. Remove the 3 screws ②.
4. Remove the A/C Head and A/C Head Spring.

NOTE

1. Do not touch the A/C Head. (Use gloves.)
2. When you install the A/C Head Spring, install as shown in Fig. 2-13-B. **(Refer to Fig. 2-13-B)**
3. When you install the A/C Head, tighten the screw (1) first, then tighten the screw (2), finally tighten the screw (3).

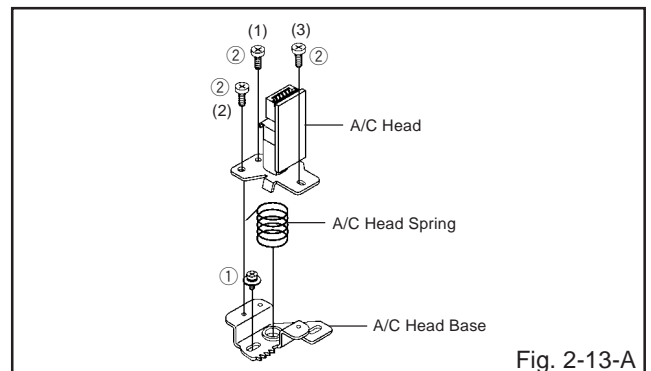

Fig. 2-13-A

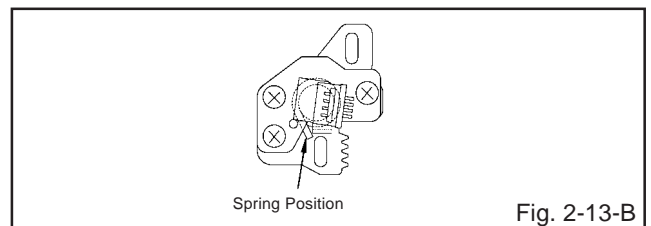

Fig. 2-13-B

2-14: FE HEAD (RECORDER ONLY) (Refer to Fig. 2-14)

1. Remove the screw ①.
2. Remove the FE Head.

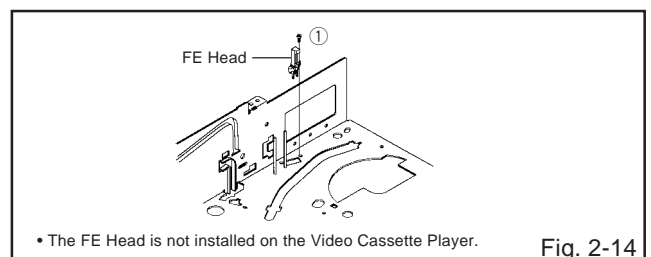

Fig. 2-14

DISASSEMBLY INSTRUCTIONS

2-15: AHC ASS'Y/CYLINDER UNIT ASS'Y (Refer to Fig. 2-15)

1. Unlock the support ① and remove the AHC Ass'y.
2. Remove the 3 screws ②.
3. Remove the Cylinder Unit Ass'y.

NOTE

When you install the Cylinder Unit Ass'y, tighten the screws from (1) to (3) in order while pulling the Ass'y toward the left front direction.

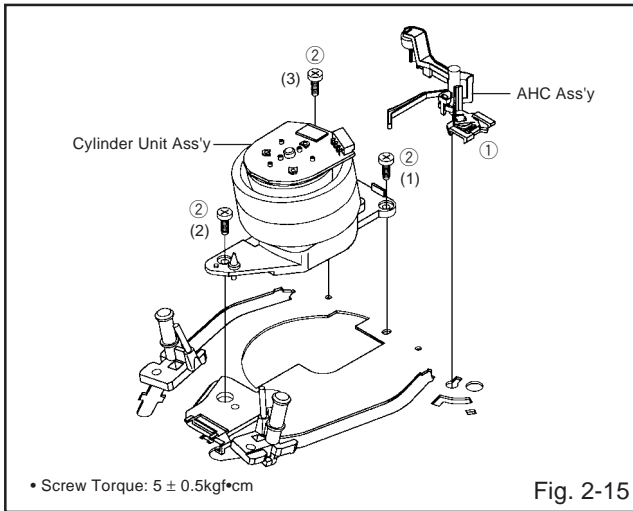

2-16: CAPSTAN DD UNIT (Refer to Fig. 2-16)

1. Remove the Capstan Belt.
2. Remove the 3 screws ①.
3. Remove the Capstan DD Unit.

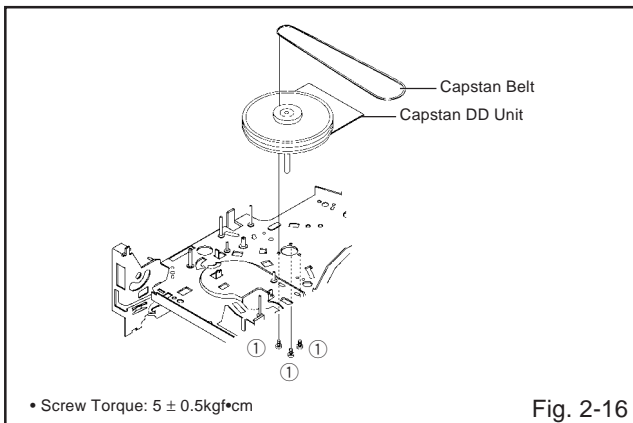

2-17: MIDDLE GEAR/MAIN CAM (Refer to Fig. 2-17-A)

1. Remove the Polyslider Washer ①, then remove the Middle Gear.
2. Remove the E-Ring, then remove the Main Cam, Link Lever Spacer and P5 Cam.
3. Remove the Polyslider Washer ②, then remove the Pinch Roller Cam.
4. Remove the Polyslider Washer ③, then remove the Joint Gear.

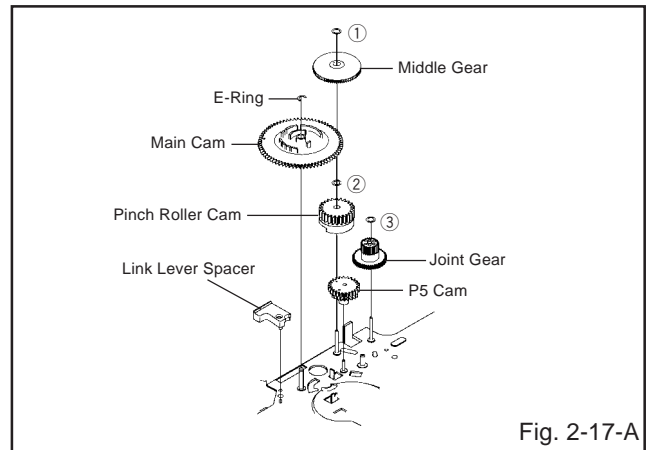

NOTE

When you install the Pinch Roller Cam, P5 Cam and Main Cam, align each marker. (Refer to Fig. 2-17-B)

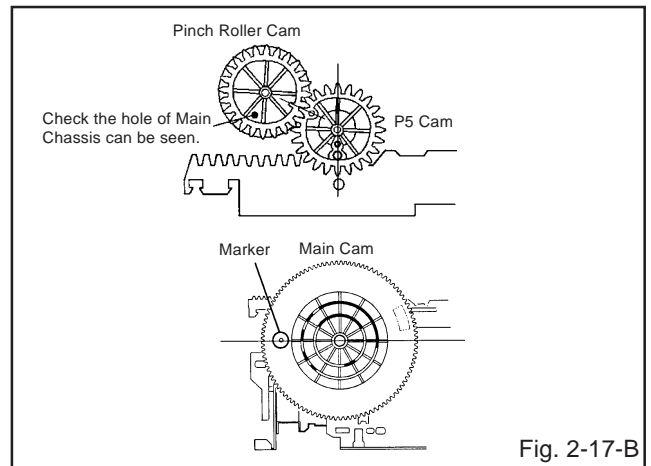

2-18: CLUTCH ASS'Y (Refer to Fig. 2-18)

1. Remove the Polyslider Washer ①.
2. Remove the Clutch Ass'y, Ring Spring, Ring Clutch, Gear Clutch and Polyslider Washer ②.

NOTE

When you install the Clutch Ass'y, oil the shaft (KYODO OIL Slidas #150).

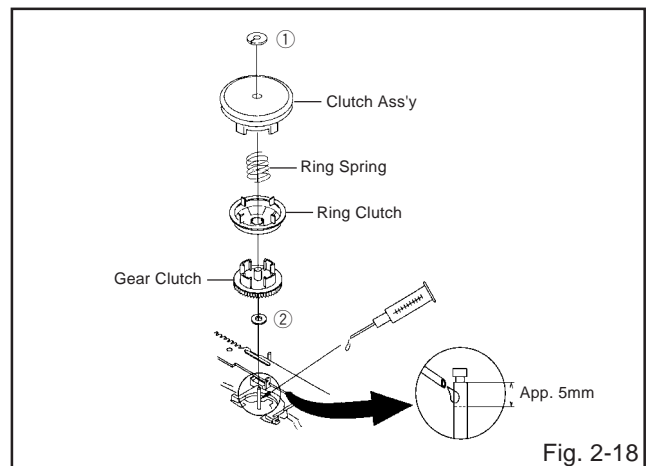

DISASSEMBLY INSTRUCTIONS

2-19: LOADING GEAR S/T ASS'Y (Refer to Fig. 2-19-A)

1. Remove the E-Ring ① and remove the Main Loading Gear.
2. Remove the Capstan Brake Spring.
3. Slide the Main Rod and remove the Capstan Brake Arm Ass'y.
4. Remove the Main Rod.
5. Remove the Tension Lever.
6. Unlock the 2 supports ② and remove the Clutch Lever.
7. Remove the screw ③.
8. Remove the LED Reflector.
9. Remove the Loading Arm S Ass'y and Loading Arm T Ass'y.
10. Remove the Loading Gear S and Loading Gear T.
11. Remove the Loading Gear Spring.

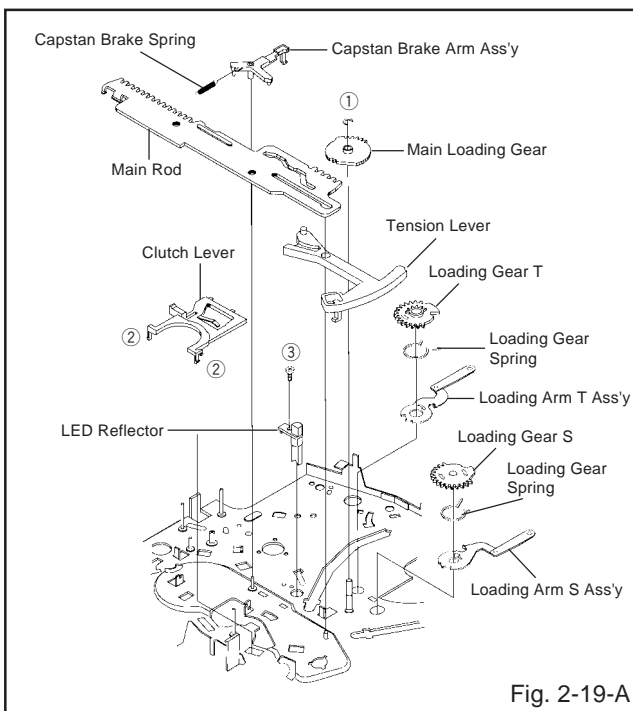

NOTE

When you install the Loading Arm S Ass'y, Loading Arm T Ass'y and Main Loading Gear, align each marker. (Refer to Fig. 2-19-B)

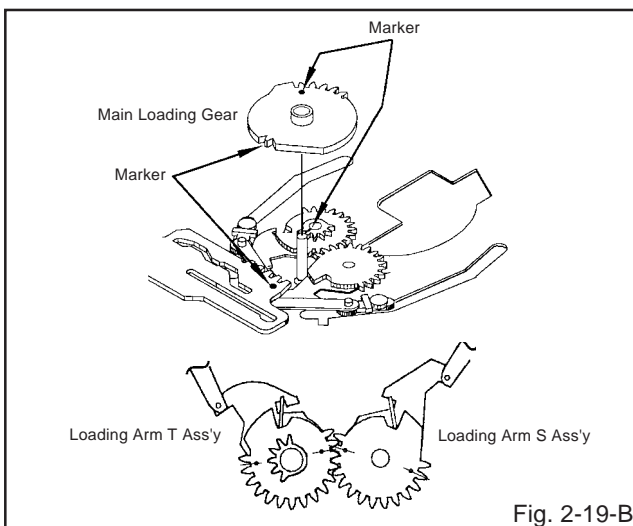

2-20: INCLINED S/T ASS'Y (Refer to Fig. 2-20)

1. Unlock the support ① and remove the P4 Cover.
2. Remove the S-S Brake Spring.
3. Unlock the support ② and remove the Loading Gear Holder.
4. Remove the S-S Brake Arm.
5. Remove the Inclined S.
6. Remove the Inclined T.
7. Remove the 2 screws ③, then remove the Guide Roller.

NOTE

Do not touch the roller of Guide Roller.

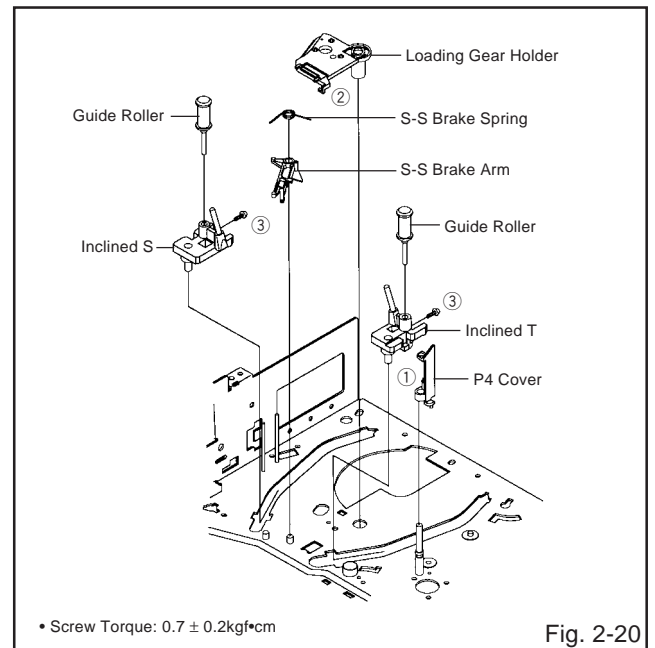

DISASSEMBLY INSTRUCTIONS

3. REMOVAL OF ANODE CAP

Read the following **NOTED** items before starting work.

- * After turning the power off there might still be a potential voltage that is very dangerous. When removing the Anode Cap, make sure to discharge the Anode Cap's potential voltage.
- * Do not use pliers to loosen or tighten the Anode Cap terminal, this may cause the spring to be damaged.

REMOVAL

1. Follow the steps as follows to discharge the Anode Cap. **(Refer to Fig. 3-1.)**

Connect one end of an Alligator Clip to the metal part of a flat-blade screwdriver and the other end to ground. While holding the plastic part of the insulated Screwdriver, touch the support of the Anode with the tip of the Screwdriver.

A cracking noise will be heard as the voltage is discharged.

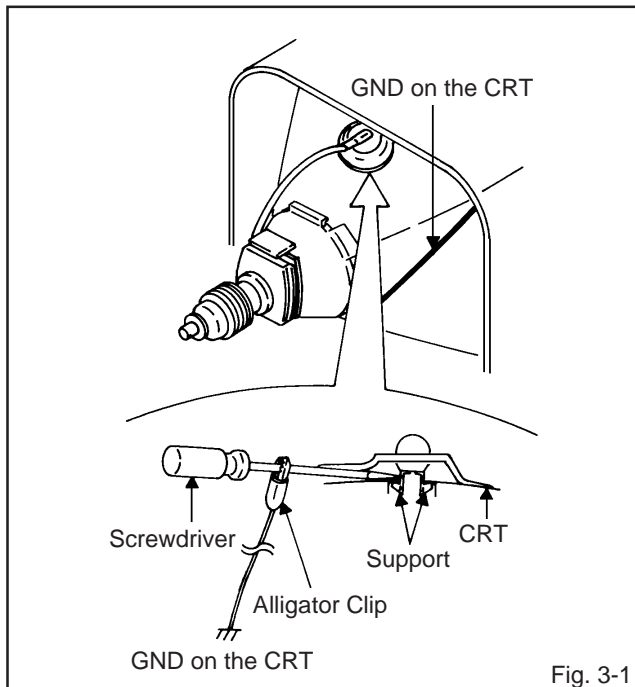

Fig. 3-1

2. Flip up the sides of the Rubber Cap in the direction of the arrow and remove one side of the support. **(Refer to Fig. 3-2.)**

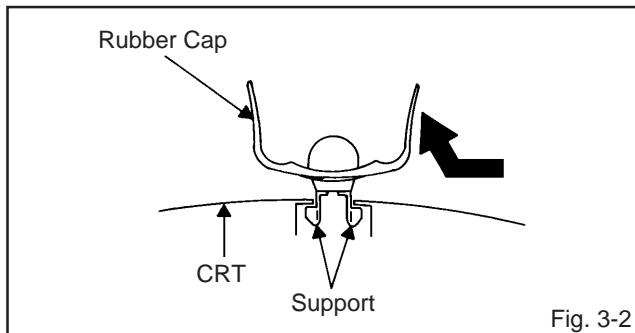

Fig. 3-2

3. After one side is removed, pull in the opposite direction to remove the other.

NOTE

Take care not to damage the Rubber Cap.

INSTALLATION

1. Clean the spot where the cap was located with a small amount of alcohol. **(Refer to Fig. 3-3.)**

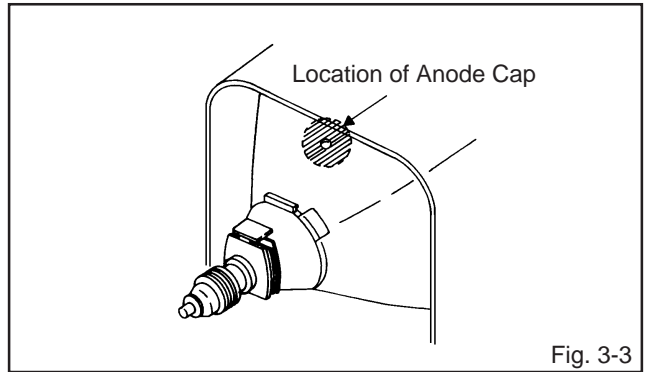

Fig. 3-3

NOTE

Confirm that there is no dirt, dust, etc. at the spot where the cap was located.

2. Arrange the wire of the Anode Cap and make sure the wire is not twisted.
3. Turn over the Rubber Cap. **(Refer to Fig. 3-4.)**

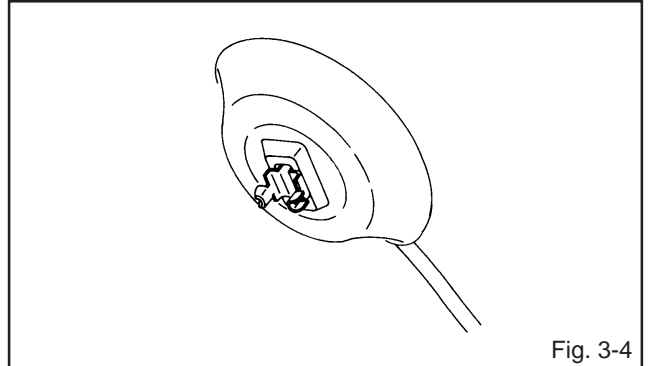

Fig. 3-4

4. Insert one end of the Anode Support into the anode button, then the other as shown in Fig. 3-5.

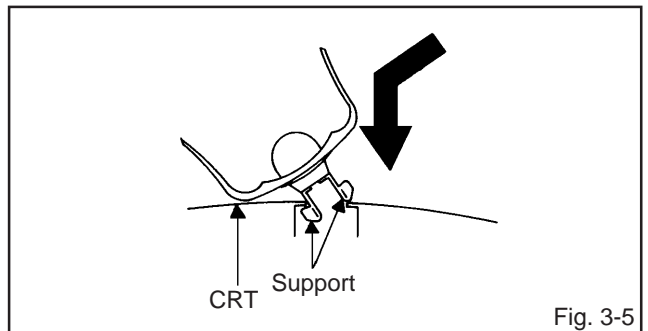

Fig. 3-5

5. Confirm that the Support is securely connected.
6. Put on the Rubber Cap without moving any parts.

KEY TO ABBREVIATIONS

A	A/C	: Audio/Control	H.SW	: Head Switch	
	ACC	: Automatic Color Control	Hz	: Hertz	
	AE	: Audio Erase	I	IC	: Integrated Circuit
	AFC	: Automatic Frequency Control		IF	: Intermediate Frequency
	AFT	: Automatic Fine Tuning		IND	: Indicator
	AFT DET	: Automatic Fine Tuning Detect		INV	: Inverter
	AGC	: Automatic Gain Control	K	KIL	: Killer
	AMP	: Amplifier	L	L	: Left
	ANT	: Antenna		LED	: Light Emitting Diode
	A.PB	: Audio Playback		LIMIT AMP	: Limiter Amplifier
	APC	: Automatic Phase Control		LM, LDM	: Loading Motor
	ASS'Y	: Assembly		LP	: Long Play
	AT	: All Time		L.P.F	: Low Pass Filter
	AUTO	: Automatic		LUMI.	: Luminance
	A/V	: Audio/Video	M	M	: Motor
B	BGP	: Burst Gate Pulse		MAX	: Maximum
	BOT	: Beginning of Tape		MINI	: Minimum
	BPF	: Bandpass Filter		MIX	: Mixer, mixing
	BRAKE SOL	: Brake Solenoid		MM	: Monostable Multivibrator
	BUFF	: Buffer		MOD	: Modulator, Modulation
	B/W	: Black and White		MPX	: Multiplexer, Multiplex
C	C	: Capacitance, Collector		MS SW	: Mecha State Switch
	CASE	: Cassette	N	NC	: Non Connection
	CAP	: Capstan		NR	: Noise Reduction
	CARR	: Carrier	O	OSC	: Oscillator
	CH	: Channel		OPE	: Operation
	CLK	: Clock	P	PB	: Playback
	CLOCK (SY-SE)	: Clock (Syscon to Servo)		PB CTL	: Playback Control
	COMB	: Combination, Comb Filter		PB-C	: Playback-Chrominance
	CONV	: Converter		PB-Y	: Playback-Luminance
	CPM	: Capstan Motor		PCB	: Printed Circuit Board
	CTL	: Control		P. CON	: Power Control
	CYL	: Cylinder		PD	: Phase Detector
	CYL-M	: Cylinder-Motor		PG	: Pulse Generator
	CYL SENS	: Cylinder-Sensor		P-P	: Peak-to Peak
D	DATA (SY-CE)	: Data (Syscon to Servo)	R	R	: Right
	dB	: Decibel		REC	: Recording
	DC	: Direct Current		REC-C	: Recording-Chrominance
	DD Unit	: Direct Drive Motor Unit		REC-Y	: Recording-Luminance
	DEMODO	: Demodulator		REEL BRK	: Reel Brake
	DET	: Detector		REEL S	: Reel Sensor
	DEV	: Deviation		REF	: Reference
E	E	: Emitter		REG	: Regulated, Regulator
	EF	: Emitter Follower		REW	: Rewind
	EMPH	: Emphasis		REV, RVS	: Reverse
	ENC	: Encoder		RF	: Radio Frequency
	ENV	: Envelope		RMC	: Remote Control
	EOT	: End of Tape		RY	: Relay
	EQ	: Equalizer	S	S. CLK	: Serial Clock
	EXT	: External		S. COM	: Sensor Common
F	F	: Fuse		S. DATA	: Serial Data
	FBC	: Feed Back Clamp		SEG	: Segment
	FE	: Full Erase		SEL	: Select, Selector
	FF	: Fast Forward, Flipflop		SENS	: Sensor
	FG	: Frequency Generator		SER	: Search Mode
	FL SW	: Front Loading Switch		SI	: Serial Input
	FM	: Frequency Modulation		SIF	: Sound Intermediate Frequency
	FSC	: Frequency Sub Carrier		SO	: Serial Output
	FWD	: Forward		SOL	: Solenoid
G	GEN	: Generator		SP	: Standard Play
	GND	: Ground		STB	: Serial Strobe
H	H.P.F	: High Pass Filter		SW	: Switch

KEY TO ABBREVIATIONS

S	SYNC	:	Synchronization
	SYNC SEP	:	Sync Separator, Separation
T	TR	:	Transistor
	TRAC	:	Tracking
	TRICK PB	:	Trick Playback
	TP	:	Test Point
U	UNREG	:	Unregulated
V	V	:	Volt
	VCO	:	Voltage Controlled Oscillator
	VIF	:	Video Intermediate Frequency
	VP	:	Vertical Pulse, Voltage Display
	V.PB	:	Video Playback
	VR	:	Variable Resistor
	V.REC	:	Video Recording
	VSF	:	Visual Search Fast Forward
	VSR	:	Visual Search Rewind
	VSS	:	Voltage Super Source
	V-SYNC	:	Vertical-Synchronization
	VT	:	Voltage Tuning
X	X'TAL	:	Crystal
Y	Y/C	:	Luminance/Chrominance

SERVICE MODE LIST

This unit provided with the following SERVICE MODES so you can repair, examine and adjust easily.

To enter SERVICE MODE, Unplug AC cord till lost actual clock time. Then press and hold Vol (-) button of main unit and remocon key simultaneously.

The both pressing of set key and remote control key will not be possible if clock has been set. To reset clock, either unplug AC cord and allow at least 5 seconds before Power On.

Set Key	Remocon Key	Operations
VOL. (-) MIN	0	Releasing of V-CHIP PASSWORD.
VOL. (-) MIN	1	Initialization of the factory. NOTE: Do not use this for the normal servicing.
VOL. (-) MIN	2	Horizontal position adjustment of OSD. NOTE: Also can be adjusted by using the Adjustment MENU. Refer to the "ELECTRICAL ADJUSTMENT" (OSD HORIZONTAL).
VOL. (-) MIN	3	Adjust the PG SHIFTER automatically. Refer to the "ELECTRICAL ADJUSTMENT" (PG SHIFTER).
VOL. (-) MIN	4	Adjust the PG SHIFTER manually. Refer to the "ELECTRICAL ADJUSTMENT" (PG SHIFTER).
VOL. (-) MIN	5	Adjusting of the Tracking to the center position. NOTE: Also can be adjusted by pressing the ATR button for more tan 2 seconds during PLAY.
VOL. (-) MIN	6	POWER ON total hours and PLAY/REC total hours are displayed on the screen. Refer to the "PREVENTIVE CHECKS AND SERVICE INTERVALS" (CONFIRMATION OF USING HOURS). Can be checked of the INITIAL DATA of MEMORY IC. Refer to the "NOTE FOR THE REPLACING OF MEMORY IC".
VOL. (-) MIN	8	Writing of EEPROM initial data. NOTE: Do not use this for the normal servicing.
VOL. (-) MIN	9	Display of the Adjustment MENU on the screen. Refer to the "ELECTRICAL ADJUSTMENT" (On-Screen Display Adjustment).

Method	Operations
Press the ATR button on the remote control for more than 2 seconds during PLAY.	Adjusting of the Tracking to the center position. Refer to the "MECHANICAL ADJUSTMENT" (GUIDE ROLLER) and "ELECTRICAL ADJUSTMENT" (PG SHIFTER).
Make the short circuit between the test point of SERVICE and the GND.	The EOT/BOT/Reel sensor do not work at this moment. Refer to the "PREPARATION FOR SERVICING"

PREVENTIVE CHECKS AND SERVICE INTERVALS

The following standard table depends on environmental conditions and usage. Unless maintenance is properly carried out, the following service intervals may be quite shortened as harmful effects may be had on other parts. Also, long term storage or misuse may cause transformation and aging of rubber parts.

Time Parts Name	500 hours	1,000 hours	1,500 hours	2,000 hours	3,000 hours	Notes
Audio Control Head	■	■	■	■	■	Clean those parts in contact with the tape.
Full Erase Head (Recorder only)	■	■	■	■	■	
Capstan Belt			■	■	●	Clean the rubber, and parts which the rubber touches.
Pinch Roller	■	■	■	■	■ ●	
Capstan DD Unit					●	
Loading Motor					●	
Tension Band					●	
Capstan Shaft	■	■	■	■	■	
Tape Running Guide Post	■	■	■	■	■	Replace when rolling becomes abnormal.
Cylinder Unit	■	■	■	■	●	Clean the Head

- : Clean
- : Replace

CONFIRMATION OF USING HOURS

POWER ON total hours and PLAY/REC total hours can be checked on the screen. Total hours are displayed in 16 system of notation.

NOTE: The confirmation of using hours will not be possible if clock has been set. To reset clock, either unplug AC cord and allow at least 5 seconds before Power On.

1. Set the VOLUME to minimum.
2. While holding down VOLUME button on front cabinet, press key 6 on remote control simultaneously.
3. After the confirmation of using hours, turn off the power.

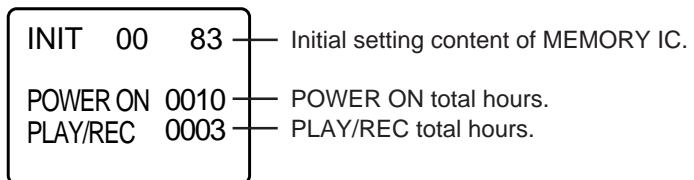

(16 x 16 x 16 x thousands digit value) + (16 x 16 x hundreds digit value) + (16 x tens digit value) + (ones digit value)

PREVENTIVE CHECKS AND SERVICE INTERVALS

CLEANING

NOTE

After cleaning the heads with isopropyl alcohol, do not run a tape until the heads dry completely. If the heads are not completely dry and alcohol gets on the tape, damage may occur.

1. AUDIO CONTROL HEAD

Wrap a piece of chamois around your finger. Dip it in isopropyl alcohol and clean the audio control head by wiping it horizontally. Clean the full erase head in the same manner. **(Refer to the figure below.)**

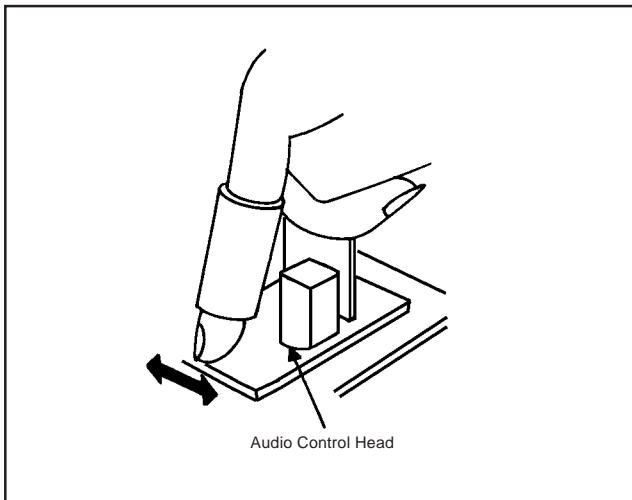

2. TAPE RUNNING SYSTEM

When cleaning the tape transport system, use the gauze moistened with isopropyl alcohol.

3. CYLINDER

Wrap a piece of chamois around your finger. Dip it in isopropyl alcohol. Hold it to the cylinder head softly. Turn the cylinder head counterclockwise to clean it (in the direction of the arrow). **(Refer to the figure below.)**

NOTE

Do not exert force against the cylinder head. Do not move the chamois upward or downward on the head. Use the chamois one by one.

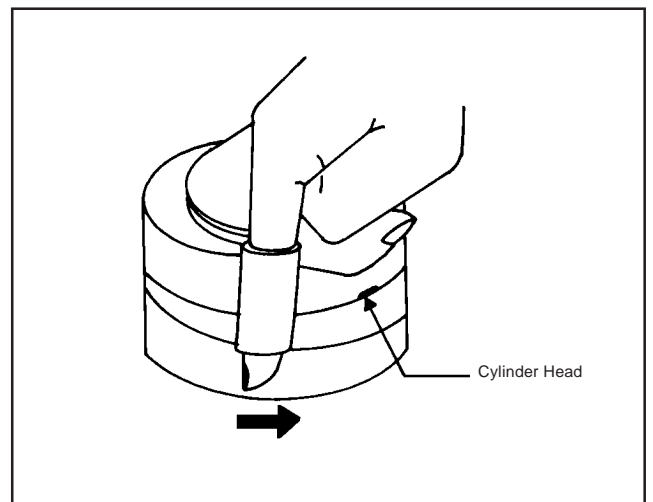

NOTE FOR THE REPLACING OF MEMORY IC

If a service repair is undertaken where it has been required to change the MEMORY IC, the following steps should be taken to ensure correct data settings while making reference to TABLE 1.

NOTE: Initial Data setting will not be possible if clock has been set. To reset clock, either unplug AC cord and allow at least 5 seconds before Power On.

ADDRESS	DATA	ADDRESS	DATA	ADDRESS	DATA	ADDRESS	DATA	ADDRESS	DATA
00	81	0A	2B	14	90	1E	43	28	39
01	6D	0B	24	15	A0	1F	13	29	02
02	07	0C	CB	16	6D	20	7D		
03	00	0D	01	17	54	21	0A		
04	00	0E	04	18	B9	22	3E		
05	00	0F	05	19	0C	23	00		
06	A4	10	6C	1A	08	24	39		
07	CB	11	2B	1B	82	25	00		
08	39	12	21	1C	6B	26	00		
09	16	13	15	1D	FA	27	3A		

Table 1

1. Enter DATA SET mode by setting VOLUME to minimum.
2. While holding down VOLUME button on front cabinet, press key 6 on remote control simultaneously.
3. ADDRESS and DATA should appear as FIG 1.

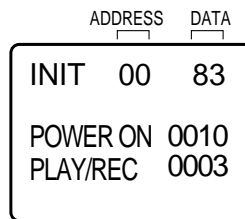
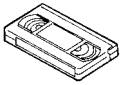
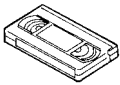
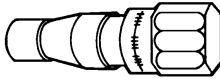
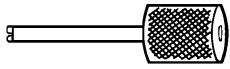
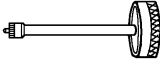
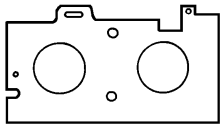
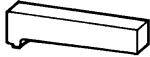
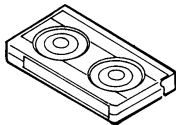
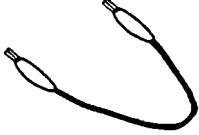
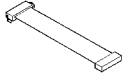
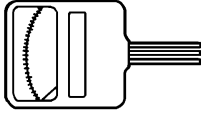

Fig. 1

4. ADDRESS is now selected and should "blink". Using the SET + or - keys on the remote, step through the ADDRESS until required ADDRESS to be changed is reached.
5. Press ENTER to select DATA. When DATA is selected, it will "blink".
6. Again, step through the DATA using SET + or - until required DATA value has been selected.
7. Pressing ENTER will take you back to ADDRESS for further selection if necessary.
8. Repeat steps 4 to 7 until all data has been checked.
9. When satisfied correct DATA has been entered, turn POWER off (return to STANDBY MODE) to finish DATA input. The unit will now have the correct DATA for the new MEMORY IC.

SERVICING FIXTURES AND TOOLS

<p>(For 2 heads model) VHS Alignment Tape JG001 (TTV-N2) JG001A (TTV-N12) JG001T (VN₂S-X6³)</p> 	<p>(For 4 heads model) VHS Alignment Tape JG001B (TTV-N2) JG001I (TTV-N12) JG001S (VN₁S-X6³)</p> 	<p>JG002B Adapter JG002E Dial Torque Gauge (10~90gf•cm) JG002F (60~600gf•cm)</p> 	<p>JG005 Post Adjustment Screwdriver Part No. SV-TG0-030-000 (small)</p> 
<p>JG153 X Value Adjustment Screwdriver</p> 	<p>JG022 Master Plane</p> 	<p>JG024A Reel Disk Height Adjustment Jig</p> 	<p>JG100A Torque Tape (VHT-063)</p> 
<p>JG154 Cable Parts No. SJ-G15-400-000</p> 	<p>JG162C Cable (10 Pins) Parts No. SJ-G16-2C0-000 JG162D Cable (11 Pins) Parts No. SJ-G16-2D0-000 JG162Y Cable (5 Pins) Parts No. SJ-G16-2Y0-000</p> 	<p>Tentelometer</p> 	

Part No.	Remarks
JG001	Stair Steps, 7KHz (For 2 heads model)
JG001A	Color Bar, 1KHz (For 2 heads model)
JG001T	X Value Adjustment (For 2 heads model)
JG001B	Stair Steps, 7KHz (For 4 heads model)
JG001I	Color Bar, 1KHz (For 4 heads model)
JG001S	X Value Adjustment (For 4 heads model)
JG002B	VSR Torque, Brake Torque (S Reel/T Reel Ass'y)
JG002E	Brake Torque (T Reel Ass'y)
JG002F	VSR Torque, Brake Torque (S Reel)
JG005	Guide Roller Adjustment
JG153	X Value Adjustment
JG022/JG024A	Reel Disk Height Adjustment
JG100A	Playback Torque, Back Tension Torque During Playback
JG154	Used to connect the test point of SERVICE and GROUND
JG162C/JG162D	Used to connect the Syscon PCB and Main PCB
JG162Y	Used to connect the Syscon PCB and CRT PCB

PREPARATION FOR SERVICING

Basic Servicing Position (In case of needing to check on all blocks)

1. Unplug the connector CP351, CP352, CP353 and CP354, then remove the TV/VCR Block from the set.
2. Unplug the connector CP810, CP820 and CP850, then remove the Main PCB from the VCR Block.
3. Connect as shown in the below figure using the Service Fixture.
 - Connect the Syscon PCB to the Main PCB with the cable JG162C and JG162D.
 - Connect the Syscon PCB to the CRT PCB with the cable JG162Y.
4. Remove the Operation PCB from the set, then connect it with the Syscon PCB.
If necessary, connect CP351. (Front A/V Jack Input Terminal)
5. Short circuit between **TP1001** and **GND** with the cable JG154.
(The EOT, BOT and Reel Sensor do not work at this moment.)
6. At that time, the STOP/EJECT button is available to insert and eject the Cassette Tape.

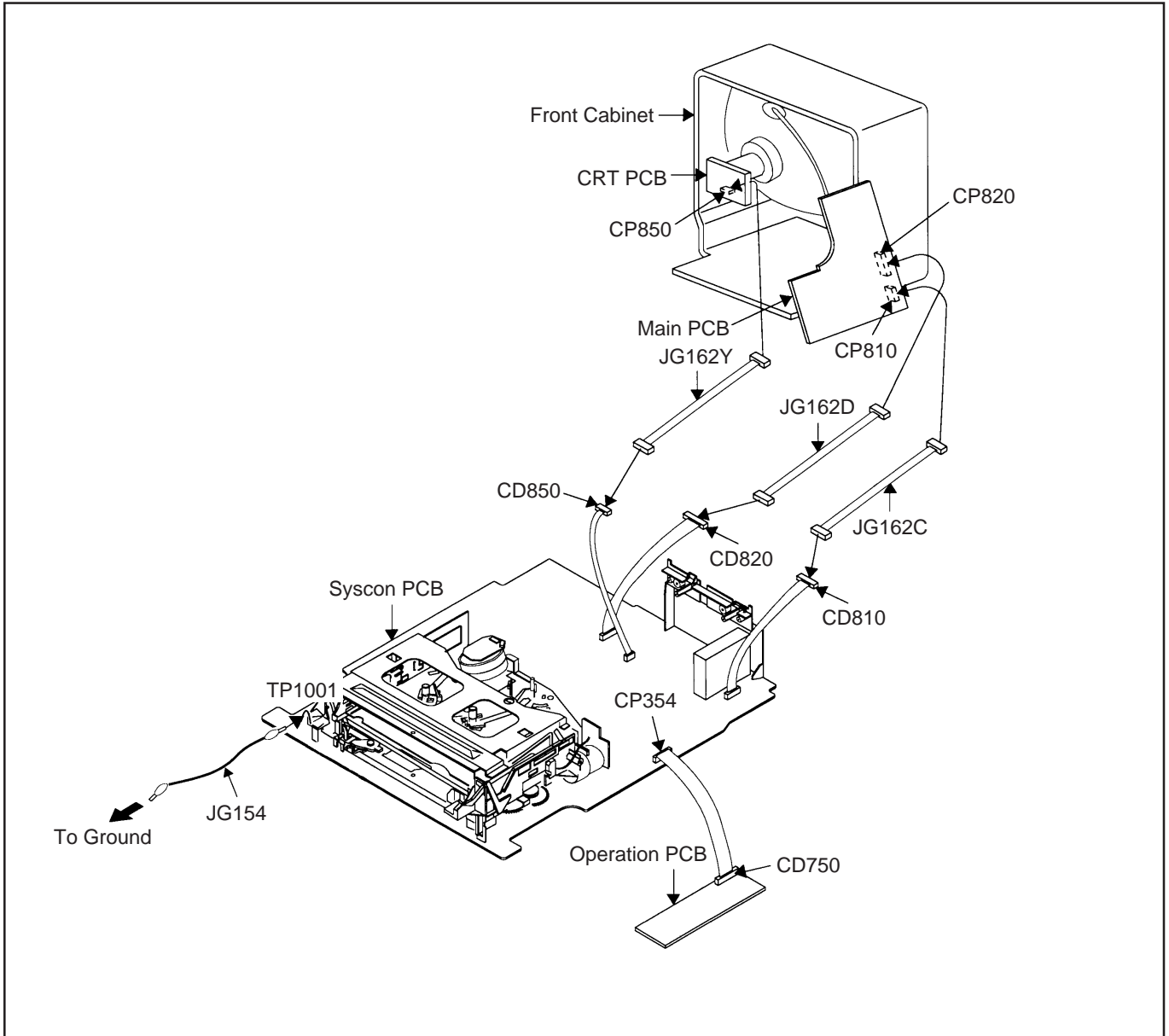

PREPARATION FOR SERVICING

Servicing Position for Main PCB (In case of needing to check on Main PCB)

- It's possible to get the Servicing Position without the extension Jig if you arrange the unit as shown below.
(But L503 connection can not be done, Degauss circuit will not operate.)

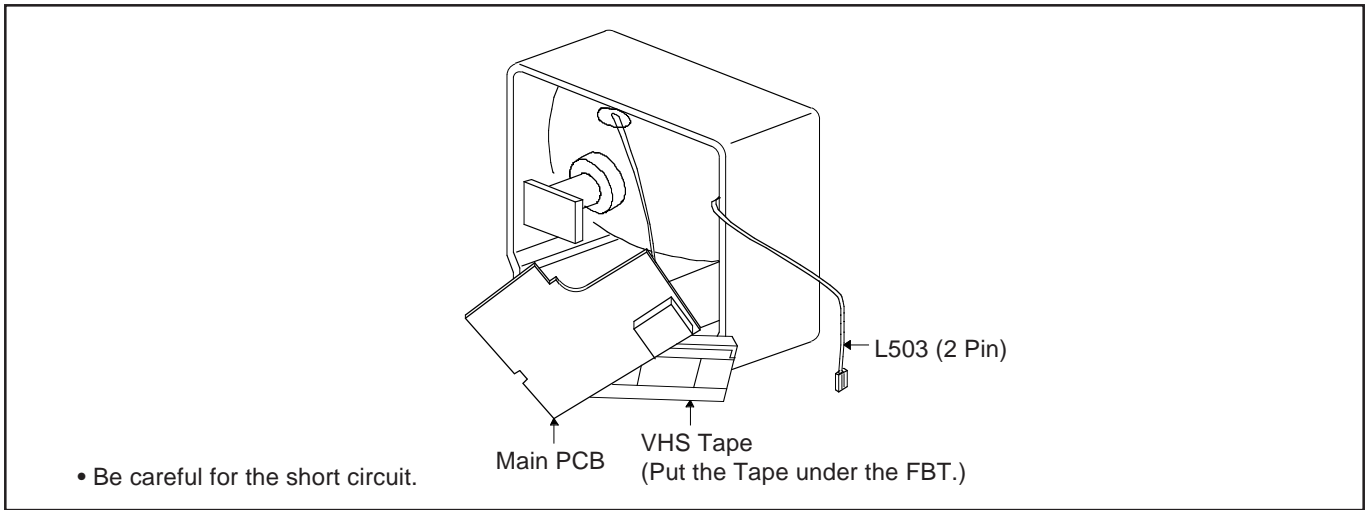

VCR TEST TAPE INTERCHANGEABILITY TABLE

There are two types of the new alignment tape CH-1B (for NTSC) and CH-2 (for PAL). On each tape four signals (1) - (4) are recorded for the times and in the order shown below.

(1) : 8min. ---> (2) : 2min. ---> (3) : 5min. ---> (4) : 5min.

The TTV-MP1 (for M-PAL), TTV-MS1 (for MESECAM) and TTV-S1 (for SECAM) alignment tapes have the same contents as the previous tapes.

Method	Now in use TYPE		New TYPE		Application
	Model	Contents*1	Model	Contents*1	
NTSC	TTV-N1	NTSC, Color, 1kHz, SP	CH-1B(2)	NTSC, Stairsteps, 1kHz, SP	PB-Y Level/General electrical ADJ. Head ACE Height/Tilt ADJ.
	TTV-N1E	NTSC, Color, 1kHz, EP	CH-1B(4) *2	NTSC, Color, 1kHz, EP	Switching position ADJ.
	TTV-N2	NTSC, Stairsteps, 7kHz, SP	CH-1B(1)	NTSC, Stairsteps, 7kHz, SP	Head ACE Azimuth ADJ.
	TTV-N12 (SCV-1998)	NTSC, Color, 1kHz, SP	CH-1B(4)	NTSC, Color, 1kHz, EP	FM envelope ADJ. X-Value ADJ.
	TTV-N7A	NTSC, Stairsteps, 1kHz, SP, HiFi 400Hz	CH-1B(3)	NTSC, Color, No sound SP, HiFi 400Hz	HiFi Audio PB Level ADJ.
PAL	TTV-P1	PAL, Color, 1kHz, SP	CH-2(2) *3	PAL, Stairsteps, 1kHz, SP	Switching position ADJ. PB-Y Level/General electrical ADJ. Head ACE Height/Tilt ADJ.
	TTV-P1L	PAL, Color, 1kHz, LP	CH-2(4)	PAL, Color, 1kHz, LP	Switching position. (LP Model) FM Envelope ADJ. (LP Model) X-Value ADJ. (LP Model)
	TTV-P2	PAL, Stairsteps, 6kHz, SP	CH-2(1)	PAL, Stairsteps, 6kHz, SP	Head ACE Azimuth ADJ. FM Envelope ADJ. (SP Model) X-Value ADJ. (SP Model)
	TTV-P7	PAL, Stairsteps, 1kHz, SP, HiFi, 1kHz	CH-2(3)	PAL, Color, No sound SP, HiFi 400Hz	HiFi Audio PB Level ADJ.
	TTV-P16	PAL, Color, 400Hz, SP, HiFi 1kHz	No Changed.		FM Filter ADJ.

*1. Described in the order of color format. Video signal. Linear audio. Tape speed and Hi-Fi audio.

*2. Use CH-1B (1) - (3) with models used exclusively in the SP mode.

*3. Use CH-2 (3) and (4) when it is necessary to observe the chroma signal.

MECHANICAL ADJUSTMENTS

1. CONFIRMATION AND ADJUSTMENT

Read the following NOTES before starting work.

- Place an object which weighs between 450g~500g on the Cassette Tape to keep it steady when you want to make the tape run without the Cassette Holder. (Do not place an object which weighs over 500g.)
- When you activate the deck without the Cassette Holder, short circuit between **TP1001** and **GND**. (Refer to **ELECTRICAL ADJUSTMENT PARTS LOCATION GUIDE**) In this condition the BOT/EOT/Reel Sensor will not function.

1-1: CONFIRMATION AND ADJUSTMENT OF REEL DISK HEIGHT

1. Turn on the power and set to the STOP mode.
2. Set the master plane (**JG022**) and reel disk height adjustment jig (**JG024A**) on the mechanism framework, taking care not to scratch the drum, as shown in **Fig. 1-1-A**.
3. Confirm that "A" of the reel disk is lower than "B" of the reel disk height adjustment jig (**JG024A**), and is higher than "C". If it is not enough height, adjust to $10(+0.2, -0)$ mm with the height adjustment washer.
4. Adjust the other reel in the same way.

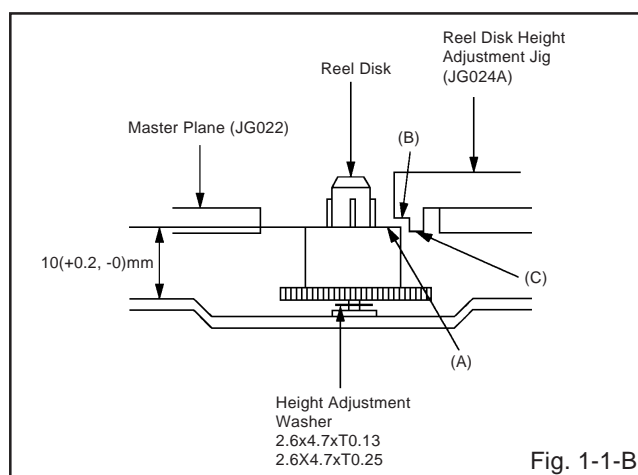
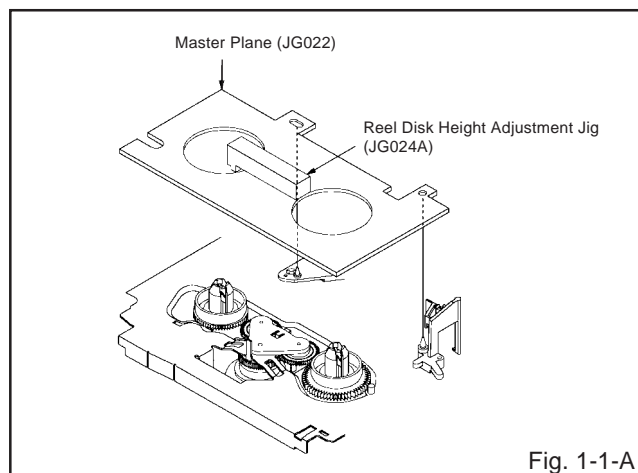

1-2: CONFIRMATION AND ADJUSTMENT OF TENSION POST POSITION

1. Set to the PLAY mode.
2. Adjust the Tension Adjust until the edge of the Tension Arm is positioning within 0.5mm range from the standard line center of Main Chassis. After this adjustment, confirm that the cut position is located in "A" area as shown in **Fig. 1-2-B**. If it is located in "B" area, adjust again.
3. While turning the S Reel clockwise, confirm that the edge of the Tension Arm is located in the position described above.

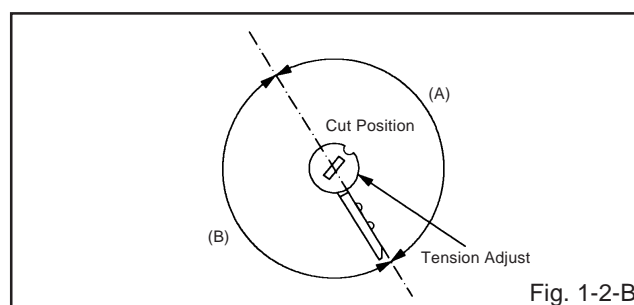
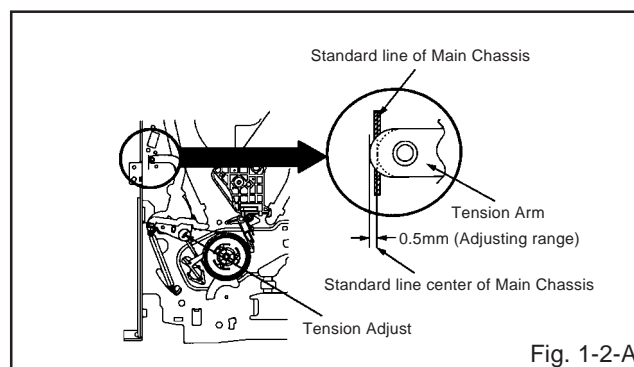

1-3: CONFIRMATION OF PLAYBACK TORQUE AND BACK TENSION TORQUE DURING PLAYBACK

1. Load a video tape (T-120) recorded in standard speed mode. Set the unit to the PLAY mode.
2. Install the tentelometer as shown in **Fig. 1-3**. Confirm that the meter indicates 20 ± 2 gf in the beginning of playback.

• USING A CASSETTE TYPE TORQUE TAPE (**JG100A**)

1. After confirmation and adjustment of Tension Post position (Refer to item 1-2), load the cassette type torque tape (**JG100A**) and set to the PLAY mode.
2. Confirm that the right meter of the torque tape indicates 70~110gf•cm during playback in SP mode.
3. Confirm that the left meter of the torque tape indicates 25~40gf•cm during playback in SP mode.

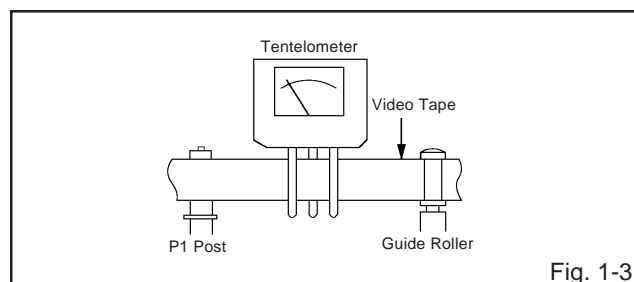

MECHANICAL ADJUSTMENTS

1-4: CONFIRMATION OF VSR TORQUE

1. Operate within 4~5 seconds after the reel disk begins to turn.
2. Install the Torque Gauge (JG002F) and Adapter (JG002B) on the S Reel. Set to the Rewind mode. (Refer to Fig.1-4)
3. Then, confirm that it indicates 120~180gf•cm.

NOTE

Install the Torque Gauge on the reel disk firmly. Press the REW button to turn the reel disk.

1-5: CONFIRMATION OF REEL BRAKE TORQUE

(S Reel Brake) (Refer to Fig. 1-4)

1. Set to the STOP mode.
2. Move the Idler Ass'y from the S Reel.
3. Install the Torque Gauge (JG002F) and Adapter (JG002B) on the S Reel. Turn the Torque Gauge (JG002F) clockwise.
4. Then, confirm that it indicates 70~100gf•cm.

(T Reel Brake) (Refer to Fig. 1-4)

1. Set to the STOP mode.
2. Move the Idler Ass'y from the T Reel Ass'y.
3. Install the Torque Gauge (JG002E) and Adapter (JG002B) on the T reel. Turn the Torque Gauge (JG002E) counterclockwise.
4. Then, confirm that it indicates 35~60gf•cm.

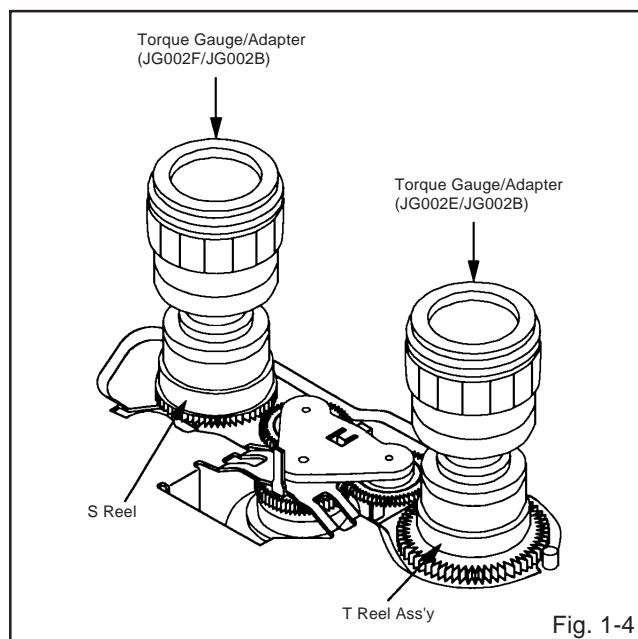

Fig. 1-4

NOTE

If the torque is out of the range, replace the following parts.

Check item	Replacement Part
1-4	Idler Ass'y/Clutch Ass'y
1-5	T Brake Spring/Tension Spring

2. CONFIRMATION AND ADJUSTMENT OF TAPE RUNNING MECHANISM

Tape Running Mechanism is adjusted precisely at the factory. Adjustment is not necessary as usual. When you replace the parts of the tape running mechanism because of long term usage or failure, the confirmation and adjustment are necessary.

2-1: GUIDE ROLLER

1. Playback the VHS Alignment Tape (JG001 or JG001B). (Refer to SERVICING FIXTURE AND TOOLS)
2. Connect CH-1 of the oscilloscope to TP4001 (Envelope) and CH-2 to TP1002 (SW Pulse).
3. Press and hold the TRACKING-AUTO button on the remote control more than 2 seconds to set tracking to center.
4. Trigger with SW Pulse and observe the envelope. (Refer to Fig. 2-1-A)
5. When observing the envelope, adjust the Adjusting Driver (JG005) slightly until the envelope will be flat. Even if you press the Tracking Button, adjust so that flatness is not moved so much.
6. Adjust so that the A : B ratio is better than 3 : 2 as shown in Fig. 2-1-B, even if you press the Tracking Button to move the envelope (The envelope waveform will begins to decrease when you press the Tracking Button).
7. Adjust the PG shifter during playback. (Refer to the ELECTRICAL ADJUSTMENTS)

NOTE

After adjustment, confirm and adjust A/C head. (Refer to item 2-2)

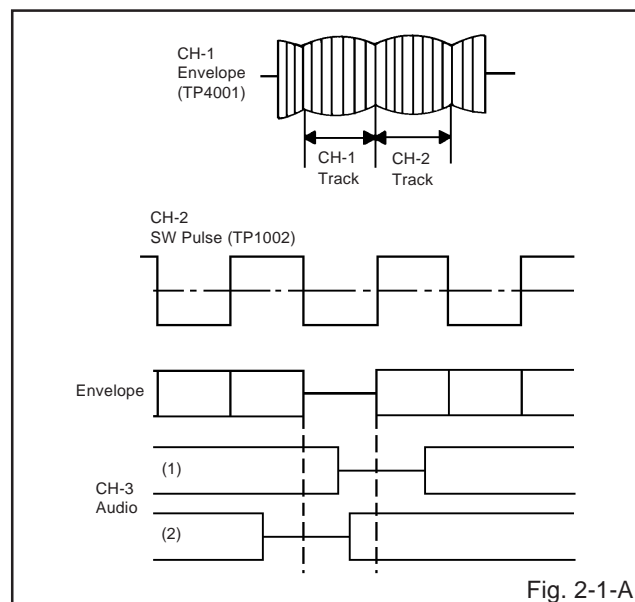

Fig. 2-1-A

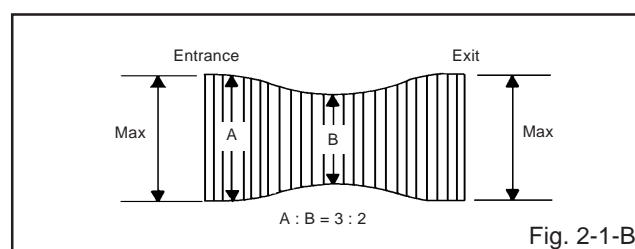

Fig. 2-1-B

MECHANICAL ADJUSTMENTS

2-2: CONFIRMATION AND ADJUSTMENT OF AUDIO/ CONTROL HEAD

When the Tape Running Mechanism does not work well, adjust the following items.

1. Playback the VHS Alignment Tape (JG001 or JG001B). (Refer to **SERVICING FIXTURE AND TOOLS**)
2. Confirm that the reflected picture of stamp mark is appeared on the tape prior to P4 Post as shown in **Fig. 2-2-A**.
 - a) When the reflected picture is distorted, turn the screw ① clockwise until the distortion is disappeared.
 - b) When the reflected picture is not distorted, turn the screw ① counterclockwise until little distortion is appeared, then adjust the a).
3. Turn the screw ② to set the audio level to maximum.
4. Confirm that the bottom of the Audio/ Control Head and the bottom of the tape is shown in **Fig. 2-2-C**.
 - c) When the height is not correct, turn the screw ③ to adjust the height. Then, adjust the 1~3 again.

2-3: TAPE RUNNING ADJUSTMENT (X VALUE ADJUSTMENT)

1. Confirm and adjust the height of the Reel Disk. (Refer to **item 1-1**)
2. Confirm and adjust the position of the Tension Post. (Refer to **item 1-2**)
3. Adjust the Guide Roller. (Refer to **item 2-1**)
4. Confirm and adjust the Audio/Control Head. (Refer to **item 2-2**)
5. Connect CH-1 of the oscilloscope to **TP4001**, CH-2 to **TP1002** and CH-3 to **HOT side of Audio Out Jack**.
6. Playback the VHS Alignment Tape (JG001S or JG001T). (Refer to **SERVICING FIXTURE AND TOOLS**)
7. Press and hold the TRACKING-AUTO button on the remote control more than 2 seconds to set tracking to center.
8. Set the X Value adjustment driver (JG153) to the ④ of **Fig. 2-2-B**. Adjust X value so that the envelope waveform output becomes maximum. Check if the relation between Audio and Envelope waveform becomes (1) or (2) of **Fig. 2-1-A**.

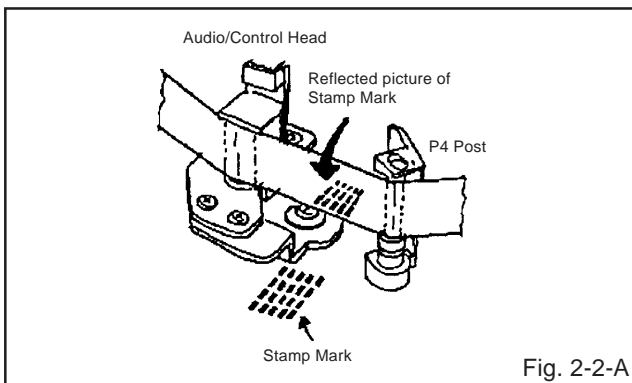

Fig. 2-2-A

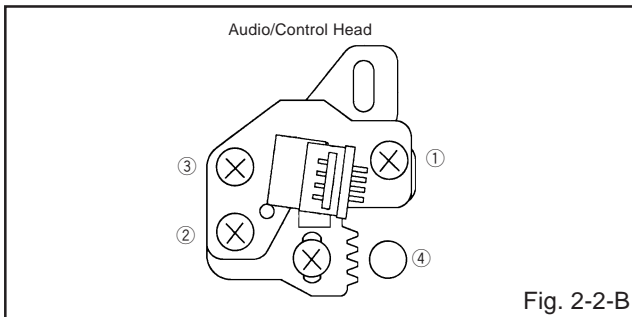

Fig. 2-2-B

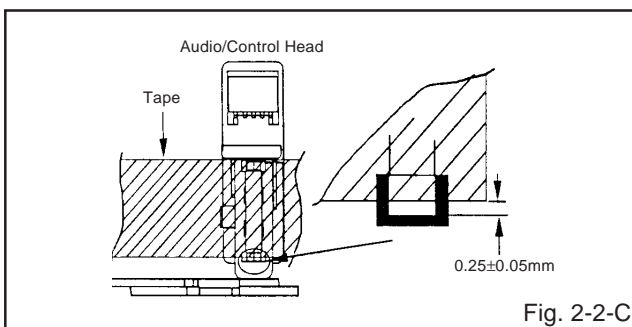
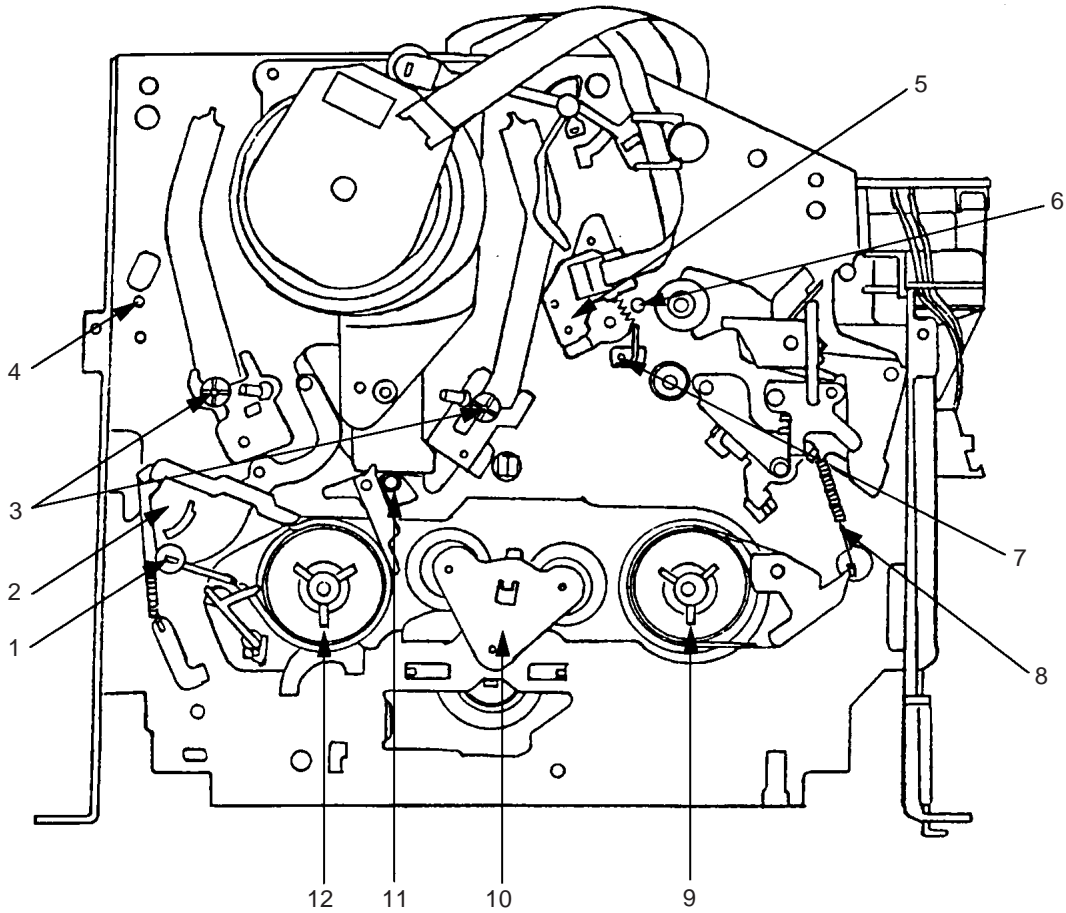

Fig. 2-2-C

MECHANICAL ADJUSTMENTS

3. MECHANISM ADJUSTMENT PARTS LOCATION GUIDE



- | | |
|-----------------------------------|----------------------|
| 1. Tension Adjust | 7. P4 Post |
| 2. Tension Arm | 8. T Brake Spring |
| 3. Guide Roller | 9. T Reel Ass'y |
| 4. P1 Post | 10. Idler Ass'y |
| 5. Audio/Control Head | 11. S-S Brake Spring |
| 6. X value adjustment driver hole | 12. S Reel |

ELECTRICAL ADJUSTMENTS

1. ADJUSTMENT PROCEDURE

Read and perform these adjustments when repairing the circuits or replacing electrical parts or PCB assemblies.

CAUTION

When replacing IC's or transistors, use only specified silicon grease (**G746**).
(To prevent the damage to IC's and transistors.)

On-Screen Display Adjustment

1. Unplug the AC plug for more than 5 seconds to set the clock to the non-setting state. Then, set the volume level to minimum.
2. Press the VOL. DOWN button on the set and the channel button (**9**) on the remote control simultaneously to display adjustment mode on the screen as shown in **Fig. 1-1**.

NOTE

Use the channel buttons (**1-8**) on the remote control to select the options shown in **Fig. 1-1**.
Press the channel button (**0**) on the remote control to end the adjustments.

1. H/V
2. AKB
3. COLOR TEMP
4. PICTURE
5. OTHERS
6. TEST PATTERN
7. STEREO/SAP
8. (VOL TEST) 0. END

"The adjustment items 3, 6, 7 and 8 are not used for this model."

Fig. 1-1

2. BASIC ADJUSTMENTS

(VCR SECTION)

2-1: PG SHIFTER

1. Connect CH-1 on the oscilloscope to **TP1002** and CH-2 to **TP4201**.
2. Playback the alignment tape. (**JG0011**)
3. Press and hold the Tracking-Auto button on the remote control more than 2 seconds to set tracking to center.
4. Press the VOL. DOWN button on the set and the channel button (**3**) on the remote control simultaneously until the indicator REC disappears. If the indicator REC disappears, adjustment is completed.

(If the above adjustments doesn't work well:)

5. Press the VOL. DOWN button on the set and the channel button (**3**) on the remote control simultaneously until the indicator REC disappears.
6. When the REC indicator is blinking, press both VOL. DOWN button on the set and the channel button (**4**) on the remote control simultaneously and adjust the Tracking +/- button until the arising to the down of Head Switching Pulse becomes $6.5 \pm 0.5H$.
(Refer to **Fig. 2-1-A, B**)
7. Press the Tracking Auto button.

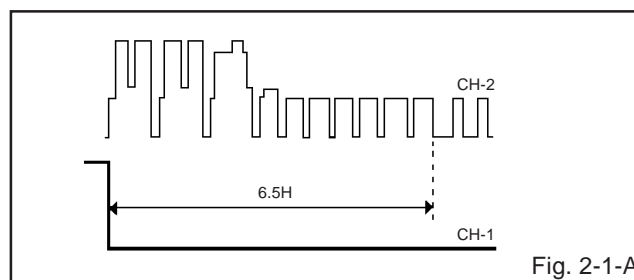

Fig. 2-1-A

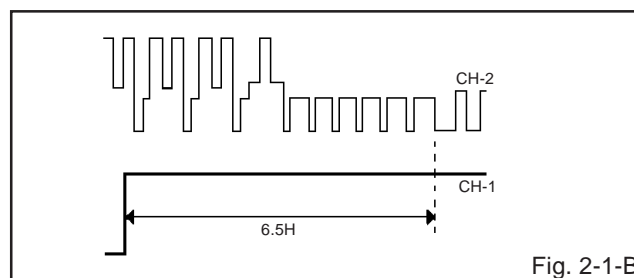

Fig. 2-1-B

2-2: VCO FREERUN

1. Place the set with Aging Test for more than 15 minutes.
2. Receive the VHF HIGH.
3. Disconnect the Antenna while receiving the VHF HIGH and set to the Noise screen.
4. Once turn off the Power and turn on the Power again.
5. Approx. 3 seconds later, input the Antenna again.
6. Connect the digital voltmeter to **TP601**.
7. Adjust the **L610** until the digital voltmeter is $3.1 \pm 0.05V$.

2-3: RF AGC

1. Receive the VHF HIGH (70dB).
2. Connect the digital voltmeter between the **pin 5 of CP603** and the **pin 1 (GND) of CP603**.
3. Activate the adjustment mode display of **Fig. 1-1** and press the channel button (**5**) on the remote control. The **Fig. 2-2** appears on the display.
4. Press the channel button (**1**) on the remote control.
5. Press the VOL. UP/DOWN button on the remote control until the digital voltmeter is $2.3 \pm 0.05V$.

1. RF AGC DELAY
2. VIDEO LEVEL
3. FM LEVEL
4. OSD H
5. CUT OFF
- 6.
- 7.
8. 0. RETURN

"The adjustment items 2 and 3 are not used for this model."

Fig. 2-2

ELECTRICAL ADJUSTMENTS

(TV SECTION)

2-4: CONSTANT VOLTAGE

1. Connect the digital voltmeter to **TP401**.
2. Set condition is AV MODE without signal.
3. Adjust the **VR502** until the DC voltage is $135 \pm 0.5V$.

2-5: OSD HORIZONTAL

1. Using the remote control, set the brightness and contrast to normal position.
2. Activate the adjustment mode display of **Fig. 1-1** and press the channel button **(5)** on the remote control. The **Fig. 2-2** appears on the display.
3. Press the channel button **(4)** on the remote control.
4. Press the VOL. UP/DOWN button on the remote control until the difference of A and B becomes minimum. (Refer to **Fig. 2-3**)

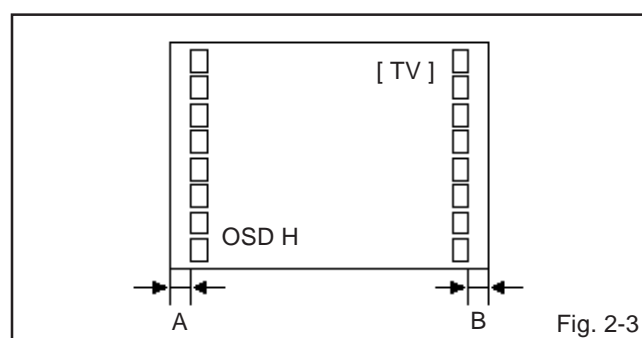

Fig. 2-3

2-6: HORIZONTAL PHASE

1. Receive the center cross signal from the Pattern Generator.
2. Using the remote control, set the brightness and contrast to normal position.
3. Activate the adjustment mode display of **Fig. 1-1** and press the channel button **(1)** on the remote control. The **Fig. 2-4** appears on the display.
4. Press the channel button **(1)** on the remote control.
5. Press the VOL. UP/DOWN button on the remote control until the right and left screen size of the vertical line becomes the same.

1. H. PHASE
2. H. BLK
3. V. SIZE
4. V. POSI
5. V. LIN
6. V. SC
7. V. COMP
8. (H FREQ) 0. RETURN

"The adjustment item 8 is not used for this model."

Fig. 2-4

2-7: VERTICAL SIZE

NOTE: Adjust after performing adjustments in section 2-6.

1. Receive the cross hatch signal from the Pattern Generator.
2. Using the remote control, set the brightness and contrast to normal position.
3. Activate the adjustment mode display of **Fig. 1-1** and press the channel button **(1)** on the remote control. The **Fig. 2-4** appears on the display.
4. Press the channel button **(3)** on the remote control.
5. Press the VOL. UP/DOWN button on the remote control until the rectangle on the center of the screen becomes square.
6. Receive a broadcast and check if the picture is normal.

2-8: VERTICAL LINEARITY

NOTE: Adjust after performing adjustments in section 2-7.

1. Receive the cross hatch signal from the Pattern Generator.
2. Using the remote control, set the brightness and contrast to normal position.
3. Activate the adjustment mode display of **Fig. 1-1** and press the channel button **(1)** on the remote control. The **Fig. 2-4** appears on the display.
4. Press the channel button **(5)** on the remote control.
5. Press the VOL. UP/DOWN button on the remote control until the SHIFT quantity of the OVER SCAN on upside and downside becomes minimum.

2-9: VERTICAL POSITION

NOTE: Adjust after performing adjustments in section 2-8.

1. Receive the center cross signal from the Pattern Generator.
2. Using the remote control, set the brightness and contrast to normal position.
3. Activate the adjustment mode display of **Fig. 1-1** and press the channel button **(1)** on the remote control. The **Fig. 2-4** appears on the display.
4. Press the channel button **(4)** on the remote control.
5. Press the VOL. UP/DOWN button on the remote control until the horizontal line becomes fit to the notch of the shadow mask.

2-10: FOCUS

1. Receive a broadcast.
2. Turn the Focus Volume fully counterclockwise once.
3. Adjust the **Focus Volume** until picture is distinct.

2-11: CUT OFF

1. Place the set with Aging Test for more than 15 minutes.
2. Set condition is AV MODE without signal.
3. Using the remote control, set the brightness and contrast to normal position.
4. Activate the adjustment mode display of **Fig. 1-1** and press the channel button **(5)** on the remote control. The **Fig. 2-2** appears on the display.
5. Press the channel button **(5)** on the remote control.
6. Adjust the **Screen Volume** until a dim raster is obtained.

ELECTRICAL ADJUSTMENTS

2-12: SUB BRIGHTNESS

1. Receive the black pattern*. (RF Input)
2. Using the remote control, set the brightness and contrast to normal position.
3. Activate the adjustment mode display of **Fig. 1-1** and press the channel button **(4)** on the remote control. The **Fig. 2-5** appears on the display.
4. Press the channel button **(1)** on the remote control.
5. Press the VOL. UP/DOWN button on the remote control until the screen begin to shine.
6. Receive the black pattern*. (Audio Video Input)
7. Press the TV/VCR button on the remote control to set to the AV mode. Then perform the above adjustments 2~5.

*The Black Pattern means the whole black raster signal. Select the "RASTER" of the pattern generator, set to the OFF position for each R, G and B.

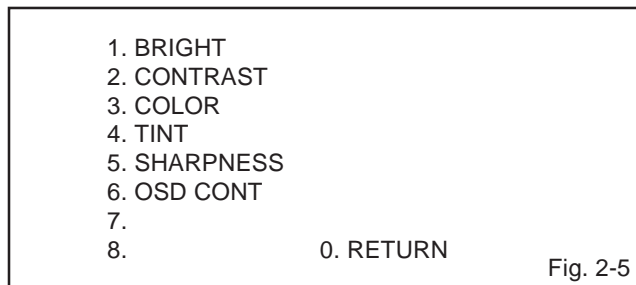

Fig. 2-5

2-13: SUB COLOR

1. Receive the color bar pattern. (RF Input)
2. Using the remote control, set the brightness, contrast, color and tint to normal position.
3. Connect the synchro scope to **TP801**.
4. Activate the adjustment mode display of **Fig. 1-1** and press the channel button **(4)** on the remote control. The **Fig. 2-5** appears on the display.
5. Press the channel button **(3)** on the remote control.
6. Adjust the VOLTS RANGE VARIABLE knob of the oscilloscope until the range between white 100% and 0% is set to 4 scales on the screen of the oscilloscope.
7. Press the VOL. UP/DOWN button on the remote control until the red color level is adjusted to $100 \pm 5\%$ of the white level. (**Refer to Fig. 2-6**)
8. Receive the color bar pattern. (Audio Video Input)
9. Press the TV/VCR button on the remote control to set to the AV mode. Then perform the above adjustments 2~7.

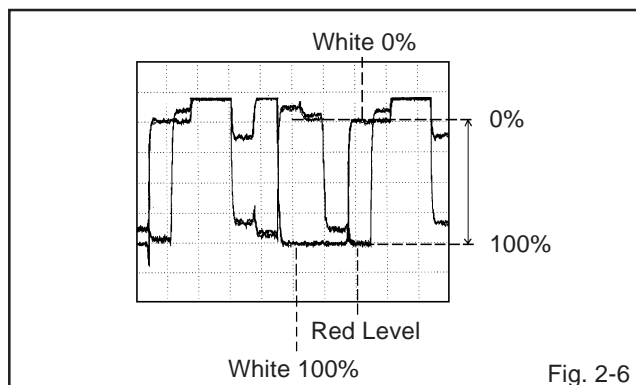

Fig. 2-6

2-14: SUB TINT

1. Receive the color bar pattern. (RF Input)
2. Using the remote control, set the brightness, contrast, color and tint to normal position.
3. Connect the synchro scope to **TP803**.
4. Activate the adjustment mode display of **Fig. 1-1** and press the channel button **(4)** on the remote control. The **Fig. 2-5** appears on the display.
5. Press the channel button **(4)** on the remote control.
6. Press the VOL. UP/DOWN button on the remote control until the section "A" becomes a straight line. (**Refer to Fig. 2-7**)
7. Receive the color bar pattern. (Audio Video Input)
8. Press the TV/VCR button on the remote control to set to the AV mode. Then perform the above adjustments 2~6.

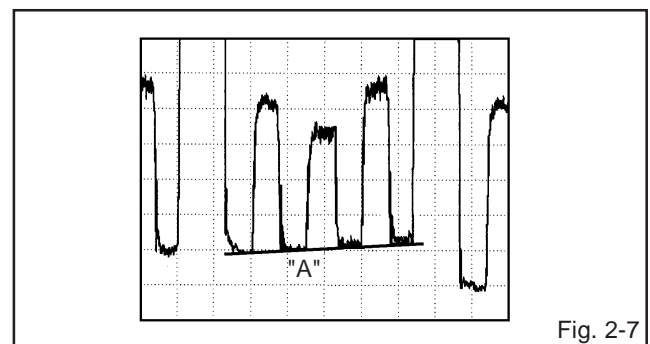

Fig. 2-7

2-15: SUB CONTRAST

1. Activate the adjustment mode display of **Fig. 1-1** and press the channel button **(4)** on the remote control. The **Fig. 2-5** appears on the display.
2. Press the channel button **(2)** on the remote control.
3. Press the VOL. UP/DOWN button on the remote control until the contrast step No. becomes "82"
4. Press the TV/VCR button on the remote control to set to the AV mode.
5. Activate the adjustment mode display of **Fig. 1-1** and press the channel button **(4)** on the remote control. The **Fig. 2-5** appears on the display.
6. Press the channel button **(2)** on the remote control.
7. Press the VOL. UP/DOWN button on the remote control until the contrast step No. becomes "97"

2-16: SUB SHARPNESS

1. Activate the adjustment mode display of **Fig. 1-1** and press the channel button **(4)** on the remote control. The **Fig. 2-5** appears on the display.
2. Press the channel button **(5)** on the remote control.
3. Check if the step No. of SHARPNESS is "24".
4. Press the TV/VCR button on the remote control to set to the AV mode. Then perform the above adjustments 1~3.

2-17: OSD CONTRAST

1. Using the remote control, set the brightness and contrast to normal position.
2. Activate the adjustment mode display of **Fig. 1-1** and press the channel button **(4)** on the remote control. The **Fig. 2-5** appears on the display.
3. Press the channel button **(6)** on the remote control.
4. Check if the step No. of OSD CONT. is "0".

ELECTRICAL ADJUSTMENTS

2-18: WHITE BALANCE

NOTE: Adjust after performing adjustments in section 2-11.

1. Place the set with Aging Test for more than 15 minutes.
2. Receive the white 100% signal from the Pattern Generator.
3. Using the remote control, set the brightness and contrast to normal position.
4. Activate the adjustment mode display of **Fig. 1-1** and press the channel button **(2)** on the remote control. The **Fig. 2-8** appears on the display.
5. Perform channel button 2 through 7 on the remote control until the screen becomes white.

1. AKB AUTO
2. R.BIAS
3. G.BIAS
4. B.BIAS
5. R.DRIVE
6. G.DRIVE
7. B.DRIVE
8. AGC AUTO 0. RETURN

"The adjustment items 1 and 8 are not used for this model."

Fig. 2-8

2-19: H. BLK

1. Activate the adjustment mode display of **Fig. 1-1** and press the channel button **(1)** on the remote control. The **Fig. 2-4** appears on the display.
2. Press the channel button **(2)** on the remote control.
3. Switch the R/L by using the ENTER button on the remote control and check if the H. BLK step No. becomes "R0, L0".

2-20: V. S-CORRECTION (V. SC)

1. Activate the adjustment mode display of **Fig. 1-1** and press the channel button **(1)** on the remote control. The **Fig. 2-4** appears on the display.
2. Press the channel button **(6)** on the remote control.
3. Check if the step No. of V. SC is "0".

2-21: V. COMP

1. Activate the adjustment mode display of **Fig. 1-1** and press the channel button **(1)** on the remote control. The **Fig. 2-4** appears on the display.
2. Press the channel button **(7)** on the remote control.
3. Check if the step No. of V. COMP is "7".

ELECTRICAL ADJUSTMENTS

3. ELECTRICAL ADJUSTMENT PARTS LOCATION GUIDE (VCR SECTION)

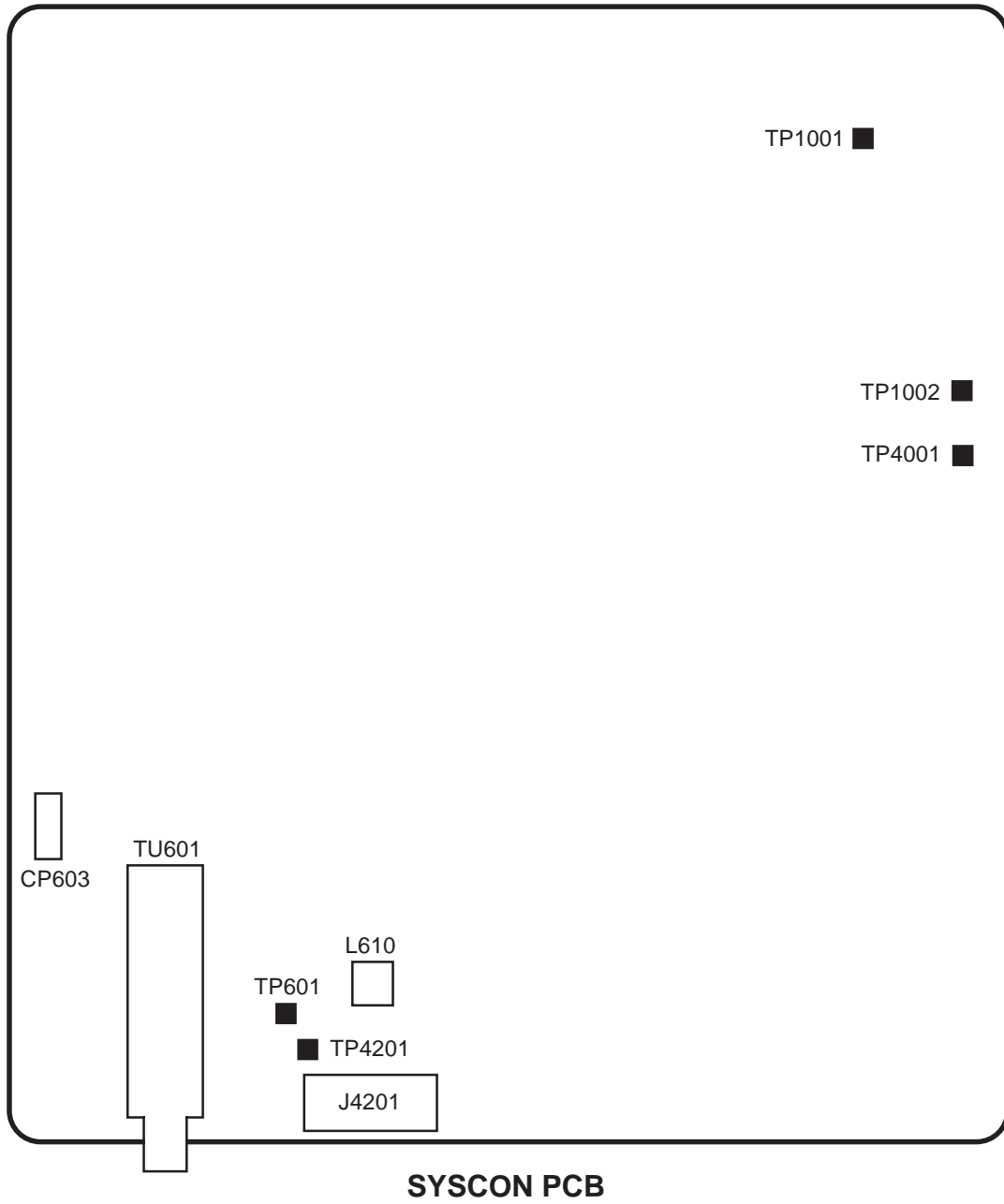

ELECTRICAL ADJUSTMENTS

(TV SECTION)

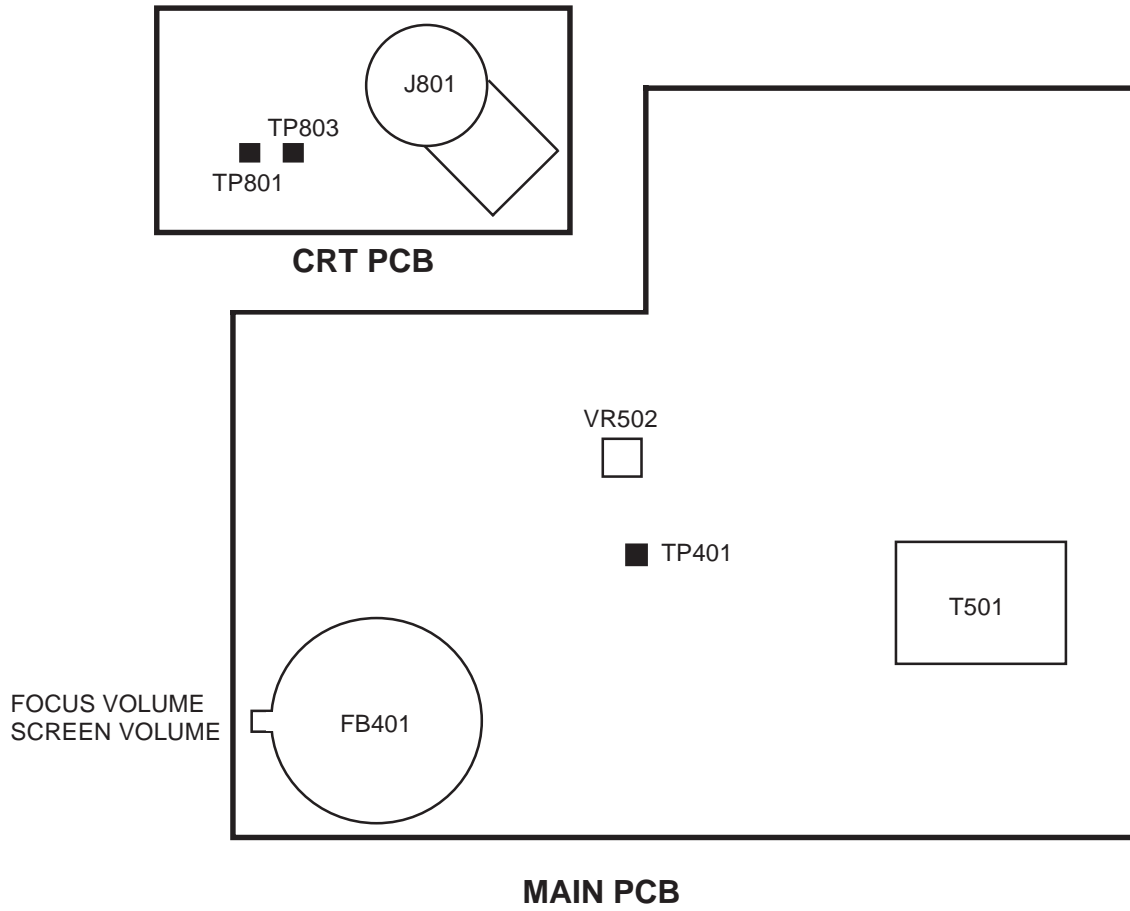

ELECTRICAL ADJUSTMENTS

4. PURITY AND CONVERGENCE ADJUSTMENTS

NOTE

1. Turn the unit on and let it warm up for at least 30 minutes before performing the following adjustments.
2. Place the CRT surface facing east or west to reduce the terrestrial magnetism.
3. Turn ON the unit and demagnetize with a Degauss Coil.

4-1: STATIC CONVERGENCE (ROUGH ADJUSTMENT)

1. Tighten the screw for the magnet. Refer to the adjusted CRT for the position. **(Refer to Fig. 4-1)**
If the deflection yoke and magnet are in one body, untighten the screw for the body.
2. Receive the green raster pattern from the color bar generator.
3. Slide the deflection yoke until it touches the funnel side of the CRT.
4. Adjust center of screen to green, with red and blue on the sides, using the pair of purity magnets.
5. Switch the color bar generator from the green raster pattern to the crosshatch pattern.
6. Combine red and blue of the 3 color crosshatch pattern on the center of the screen by adjusting the pair of 4 pole magnets.
7. Combine red/blue (magenta) and green by adjusting the pair of 6 pole magnets.
8. Adjust the crosshatch pattern to change to white by repeating steps 6 and 7.

4-2: PURITY

NOTE

Adjust after performing adjustments in section 4-1.

1. Receive the green raster pattern from color bar generator.
2. Adjust the pair of purity magnets to center the color on the screen.
Adjust the pair of purity magnets so the color at the ends are equally wide.
3. Move the deflection yoke backward (to neck side) slowly, and stop it at the position when the whole screen is green.
4. Confirm red and blue colors.
5. Adjust the slant of the deflection yoke while watching the screen, then tighten the fixing screw.

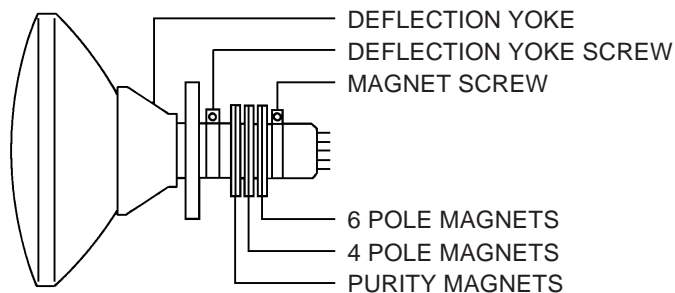

Fig. 4-1

4-3: STATIC CONVERGENCE

NOTE

Adjust after performing adjustments in section 4-2.

1. Receive the crosshatch pattern from the color bar generator.
2. Combine red and blue of the 3 color crosshatch pattern on the center of the screen by adjusting the pair of 4 pole magnets.
3. Combine red/blue (magenta) and green by adjusting the pair of 6 pole magnets.

4-4: DYNAMIC CONVERGENCE

NOTE

Adjust after performing adjustments in section 4-3.

1. Adjust the differences around the screen by moving the deflection yoke upward/downward and right/left. **(Refer to Fig. 4-2-a)**
2. Insert three wedges between the deflection yoke and CRT funnel to fix the deflection yoke. **(Refer to Fig. 4-2-b)**

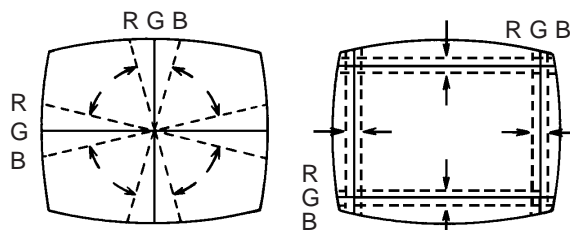

UPWARD/DOWNWARD SLANT RIGHT/LEFT SLANT

Fig. 4-2-a

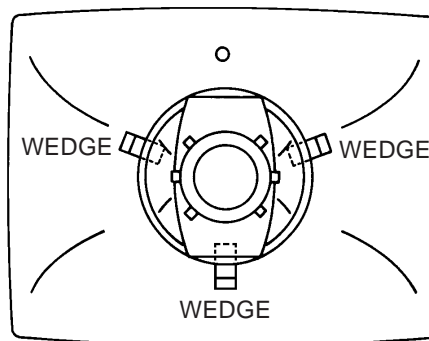

WEDGE POSITION

Fig. 4-2-b

TROUBLESHOOTING GUIDE

(Television division)

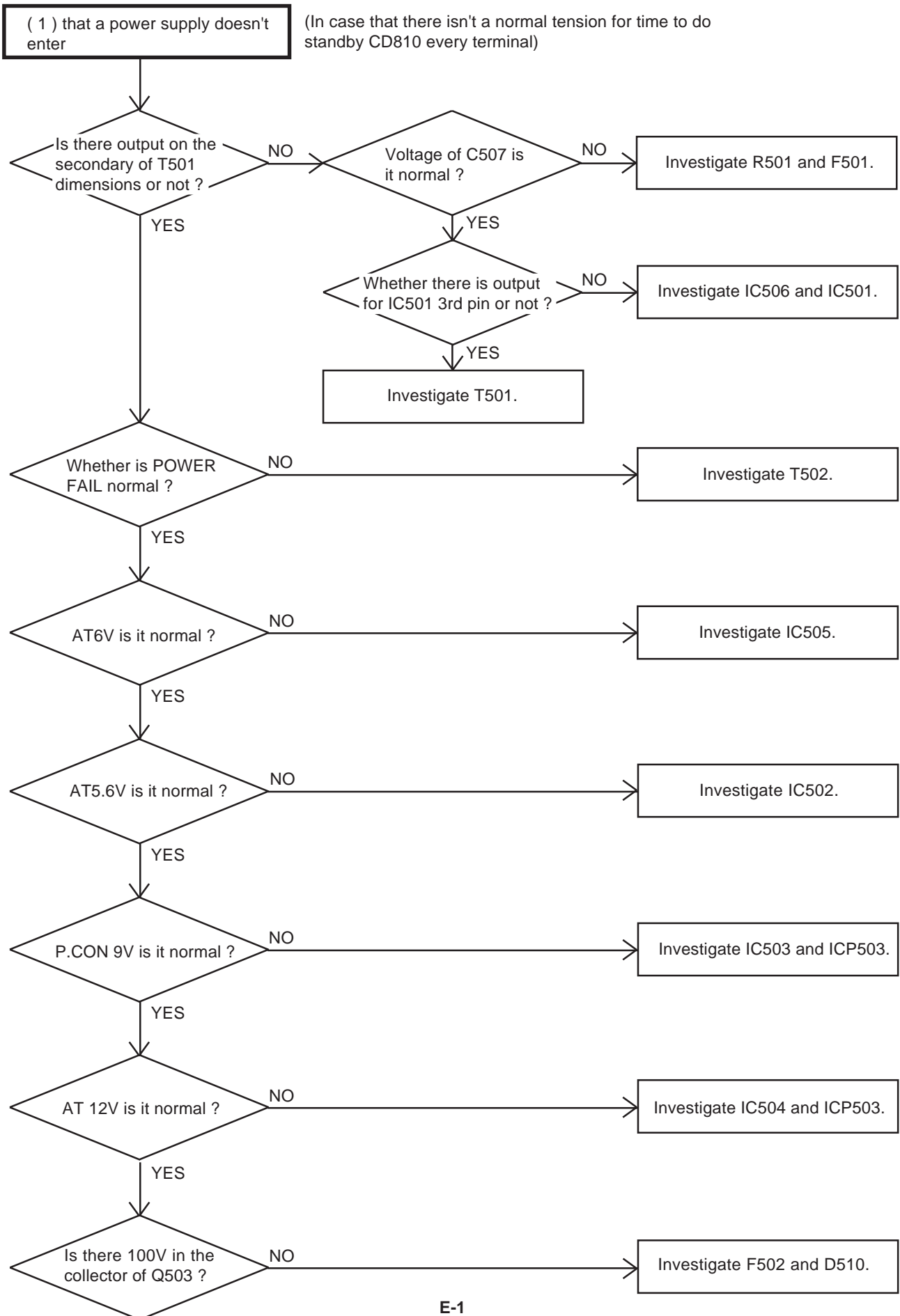

TROUBLESHOOTING GUIDE

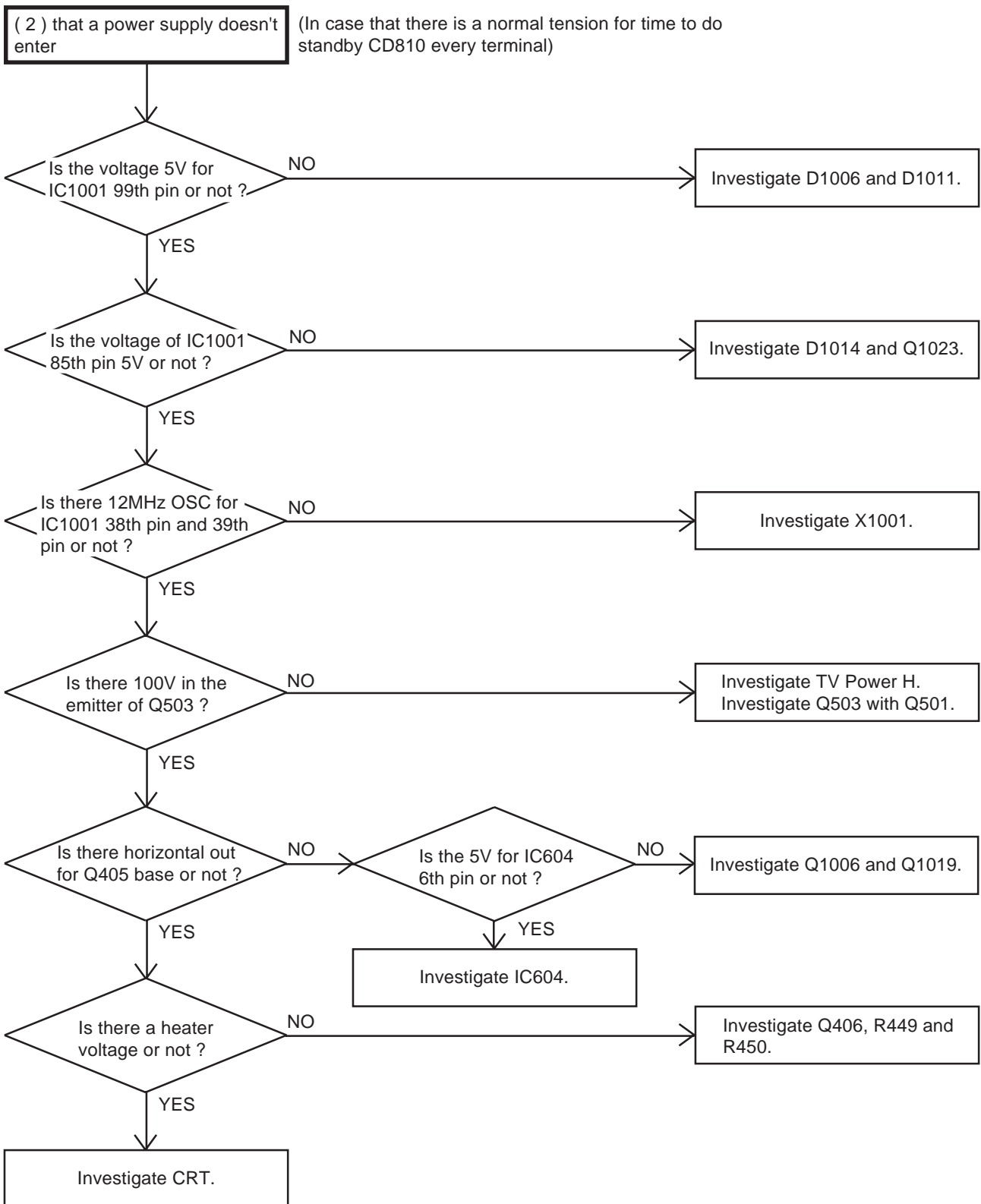

TROUBLESHOOTING GUIDE

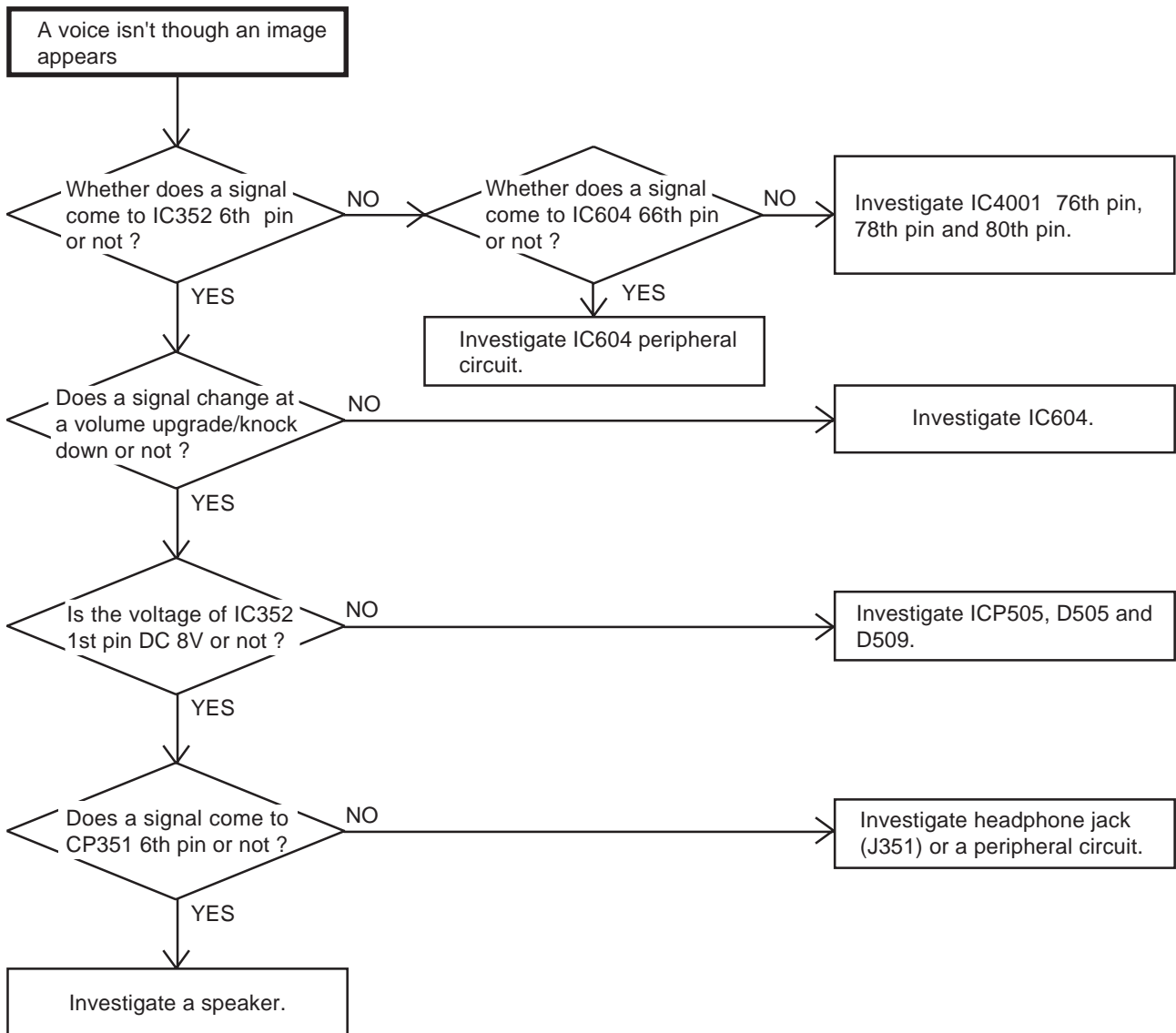

TROUBLESHOOTING GUIDE

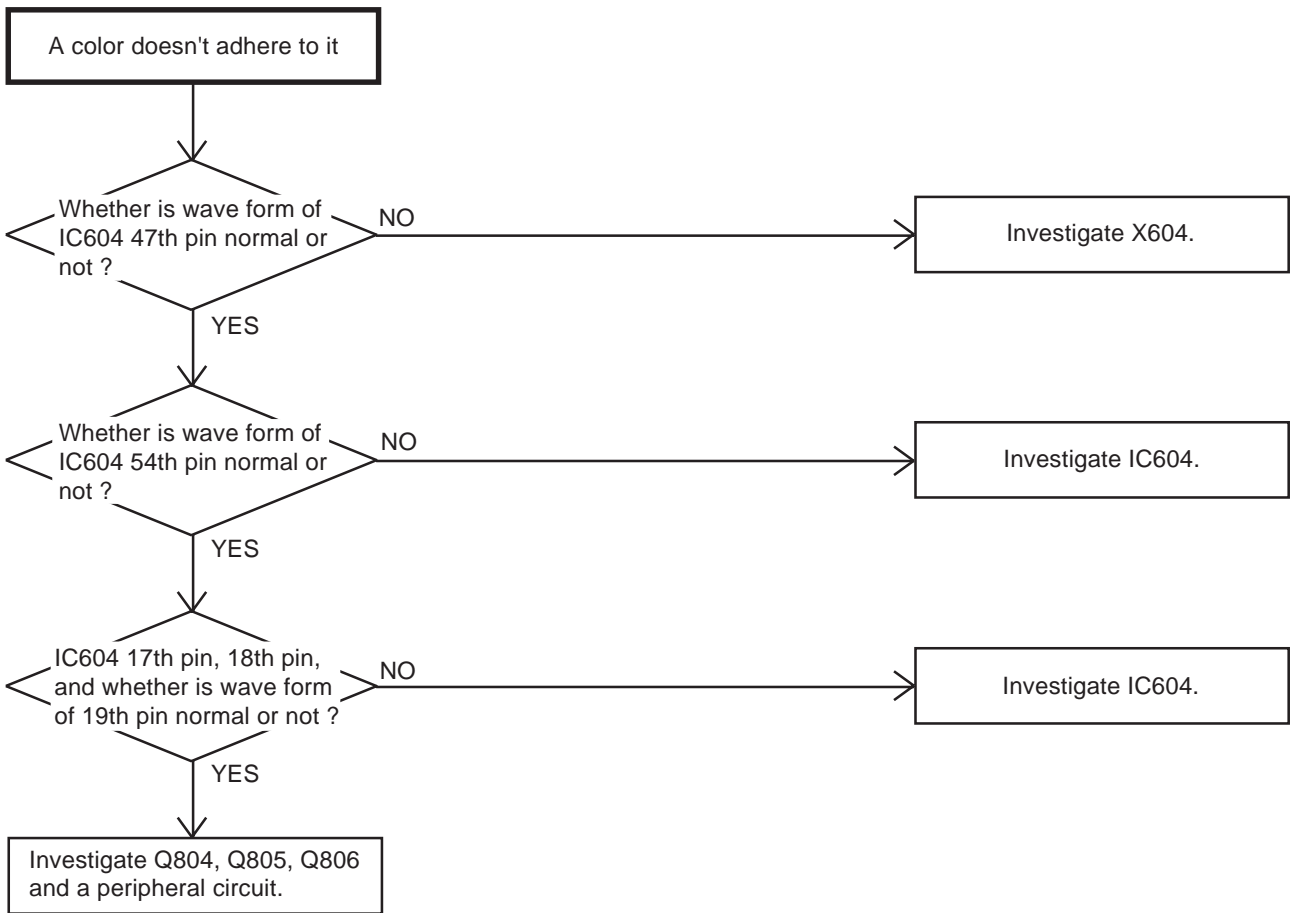

TROUBLESHOOTING GUIDE

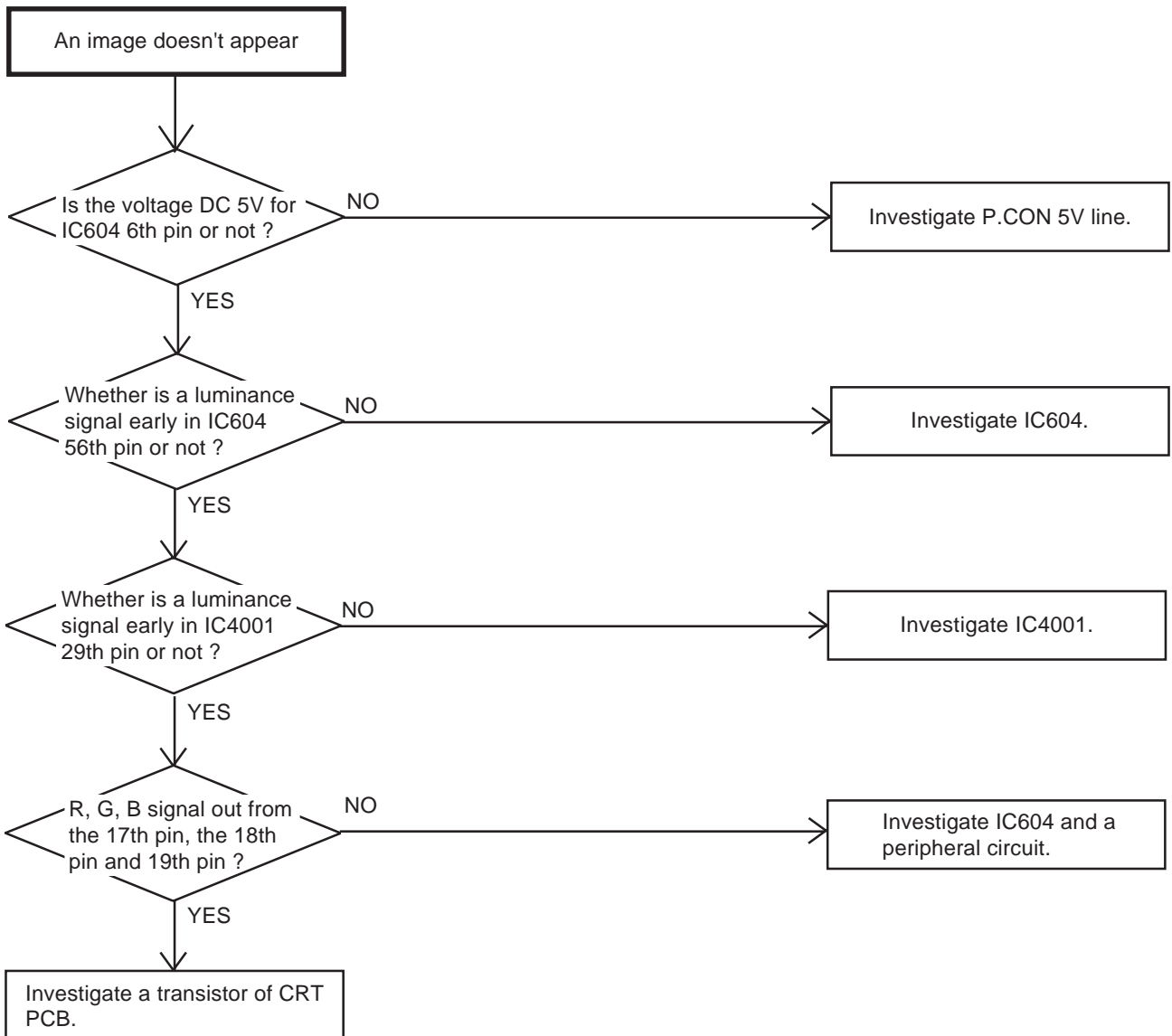

TROUBLESHOOTING GUIDE

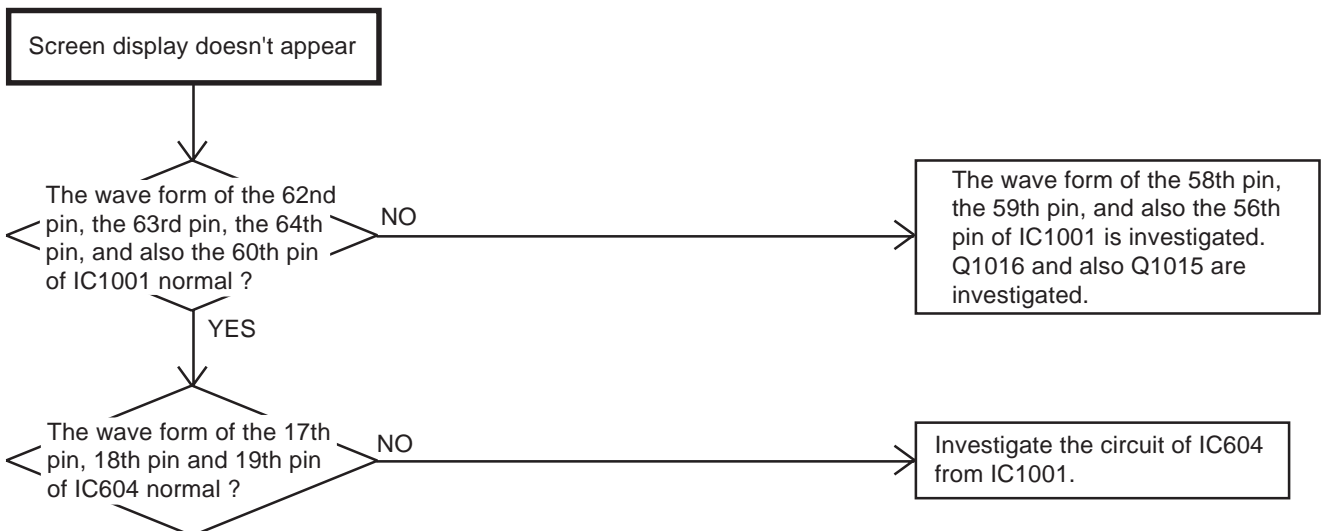
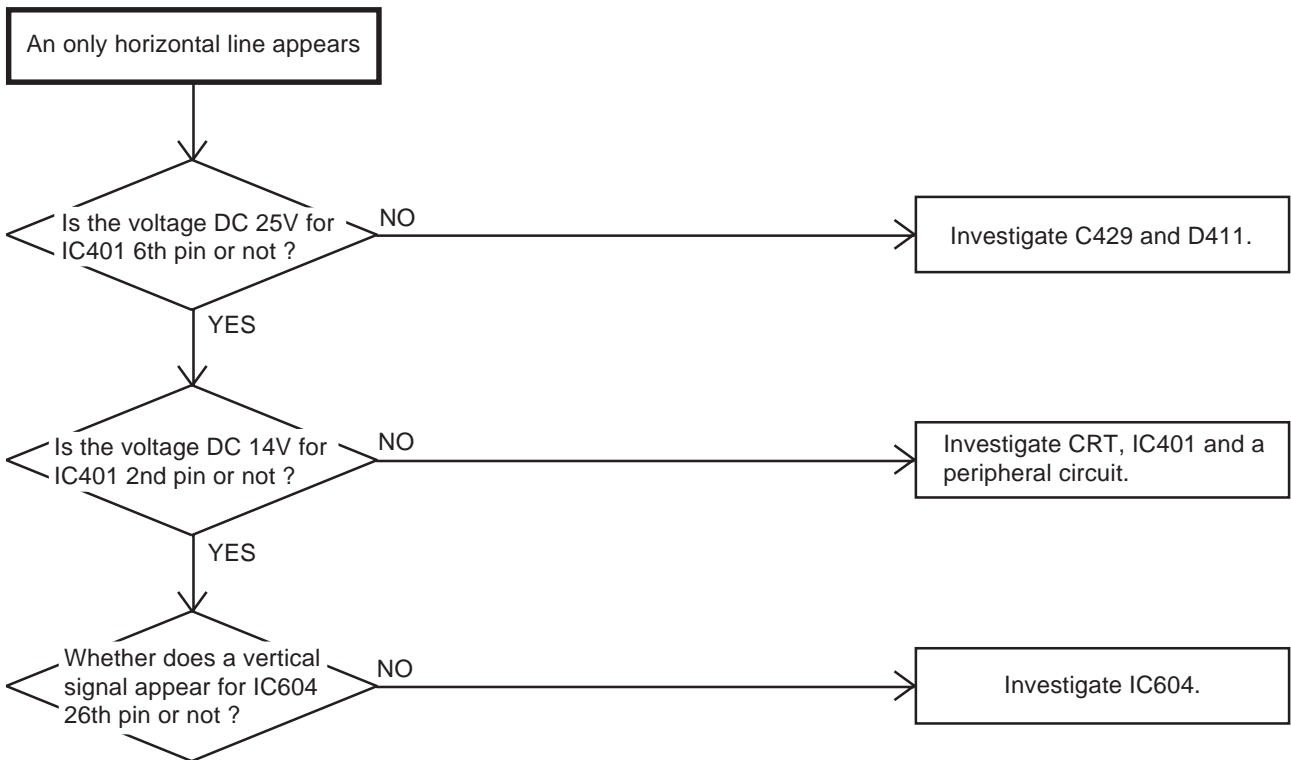

TROUBLESHOOTING GUIDE

(VCR SECTION)

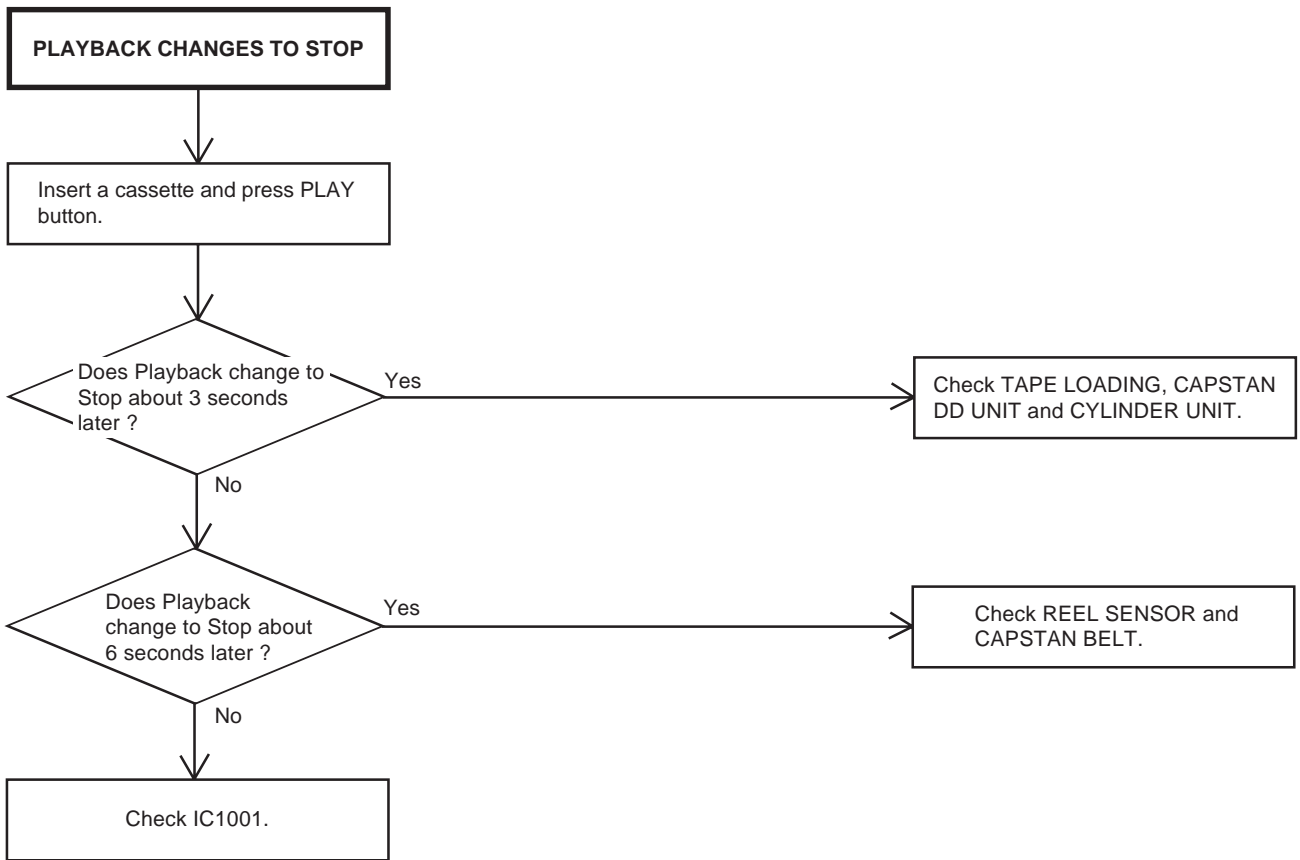

TROUBLESHOOTING GUIDE

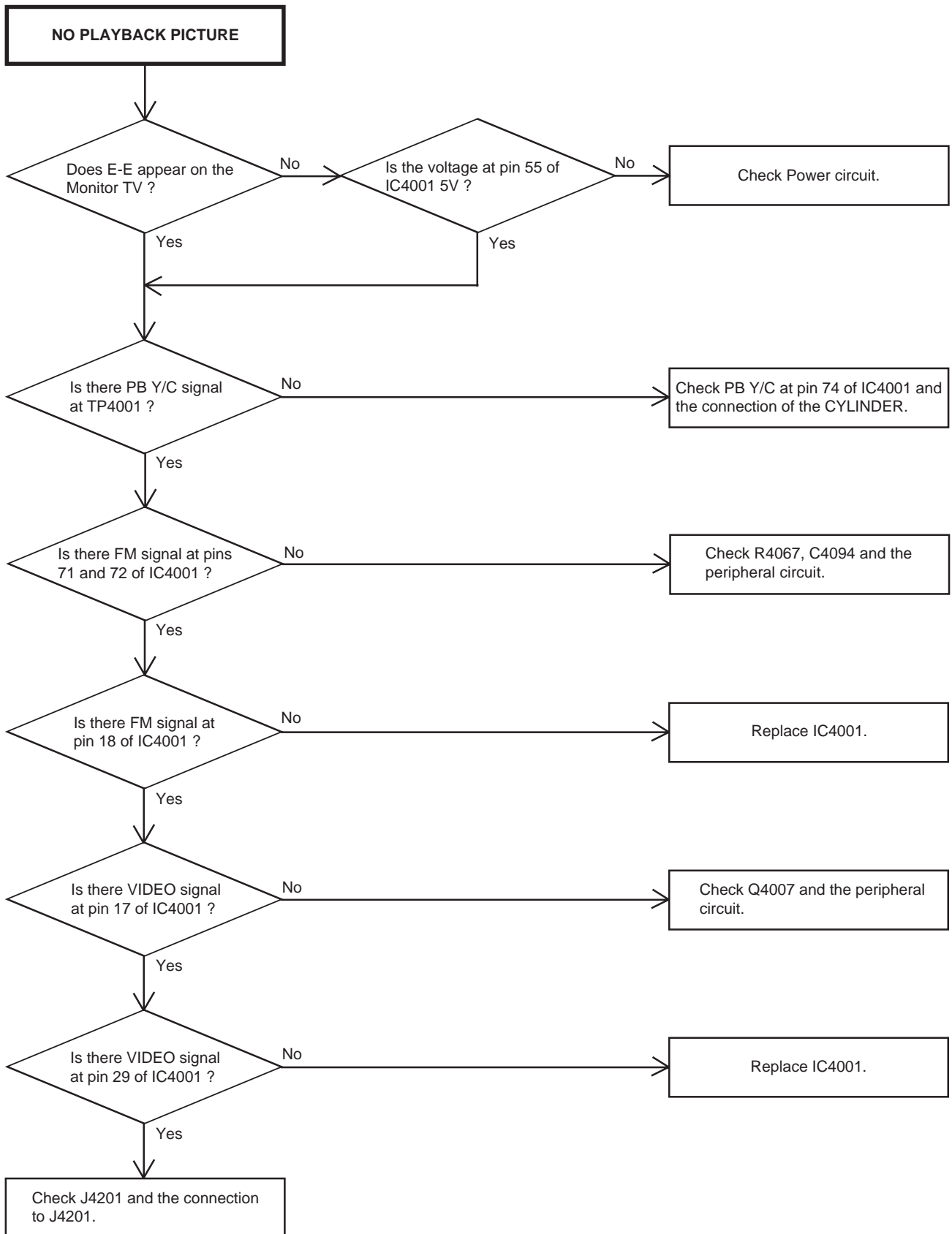

TROUBLESHOOTING GUIDE

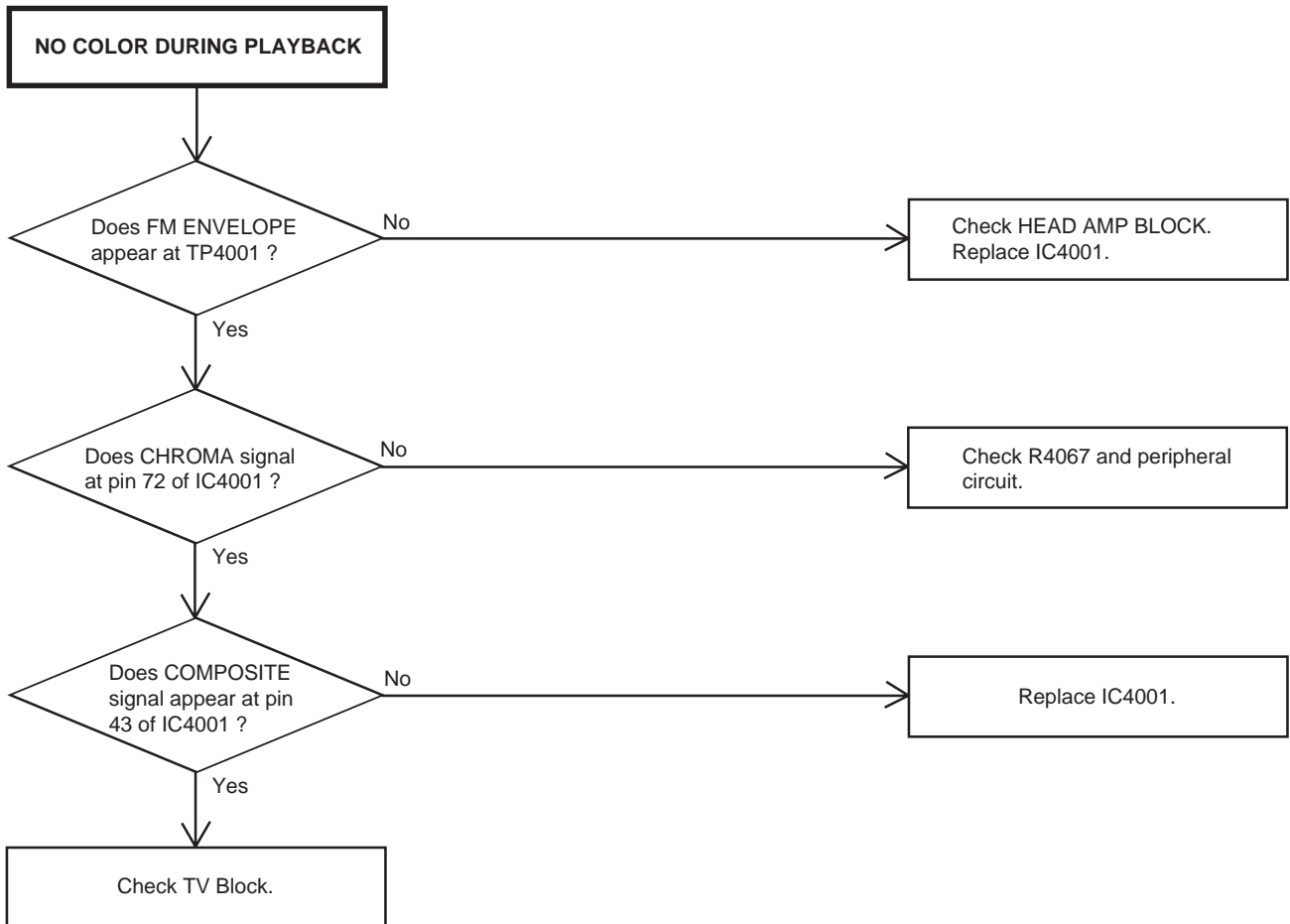

TROUBLESHOOTING GUIDE

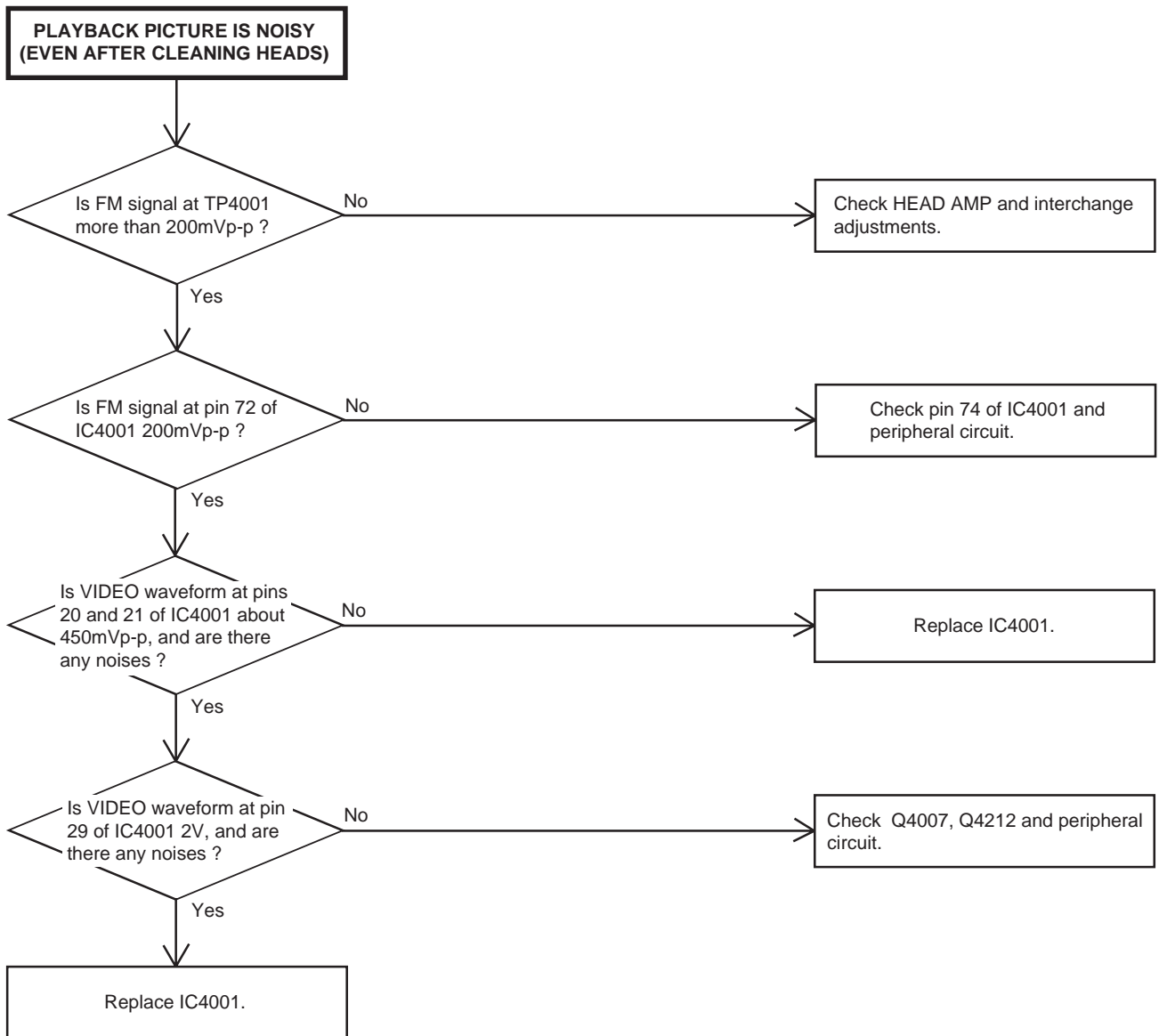

TROUBLESHOOTING GUIDE

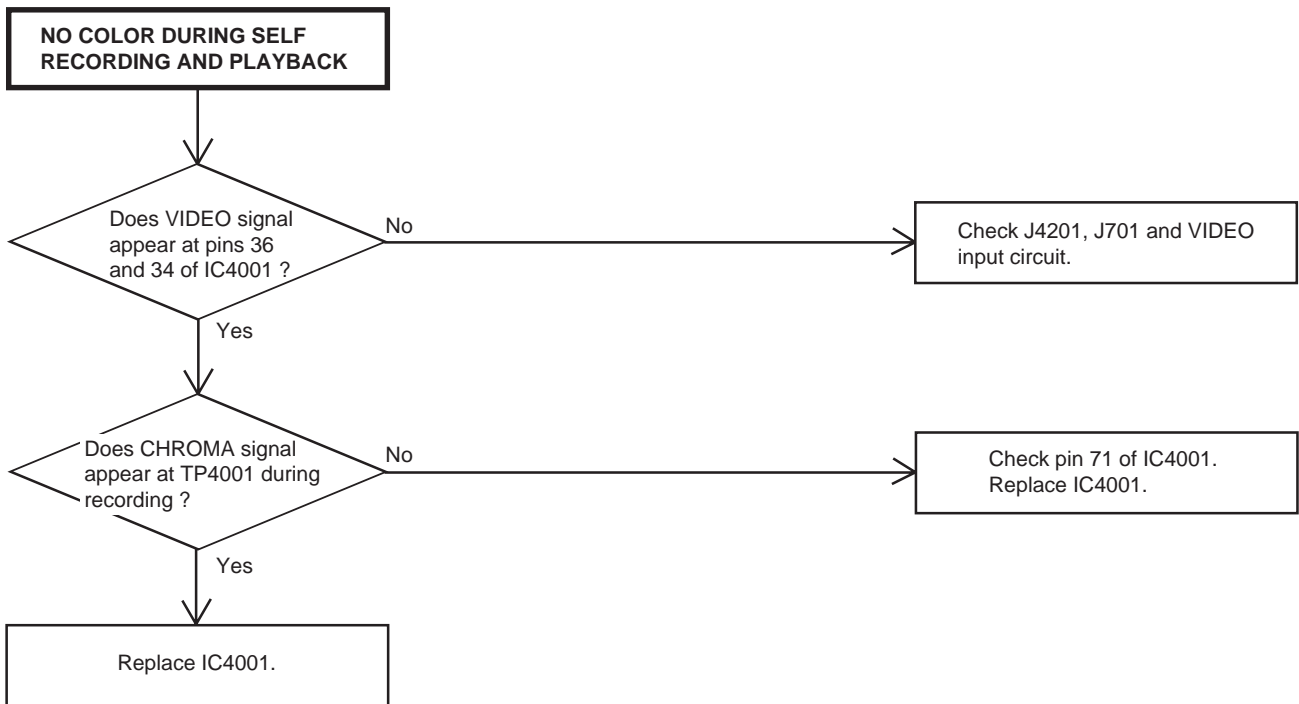

TROUBLESHOOTING GUIDE

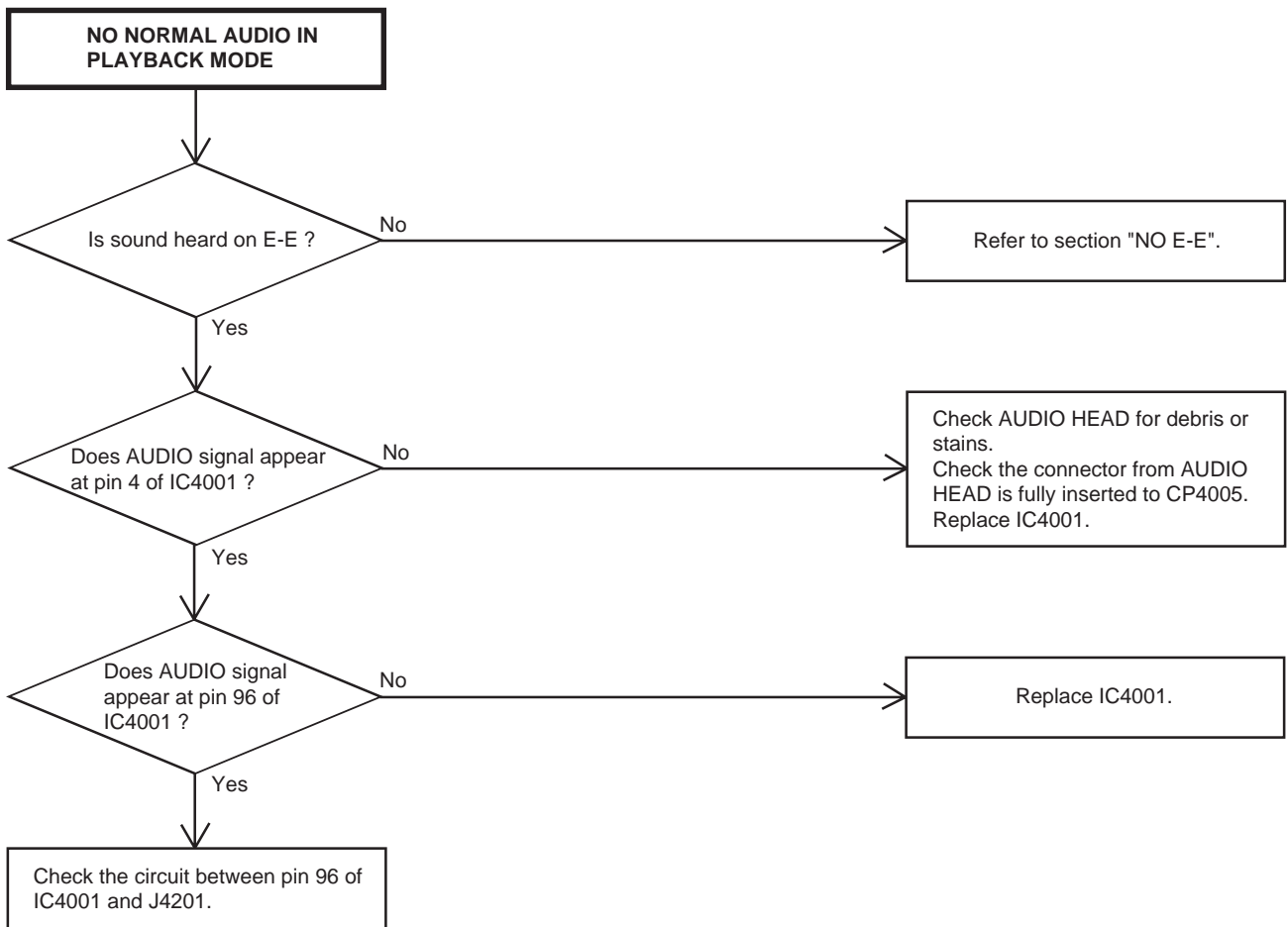

TROUBLESHOOTING GUIDE

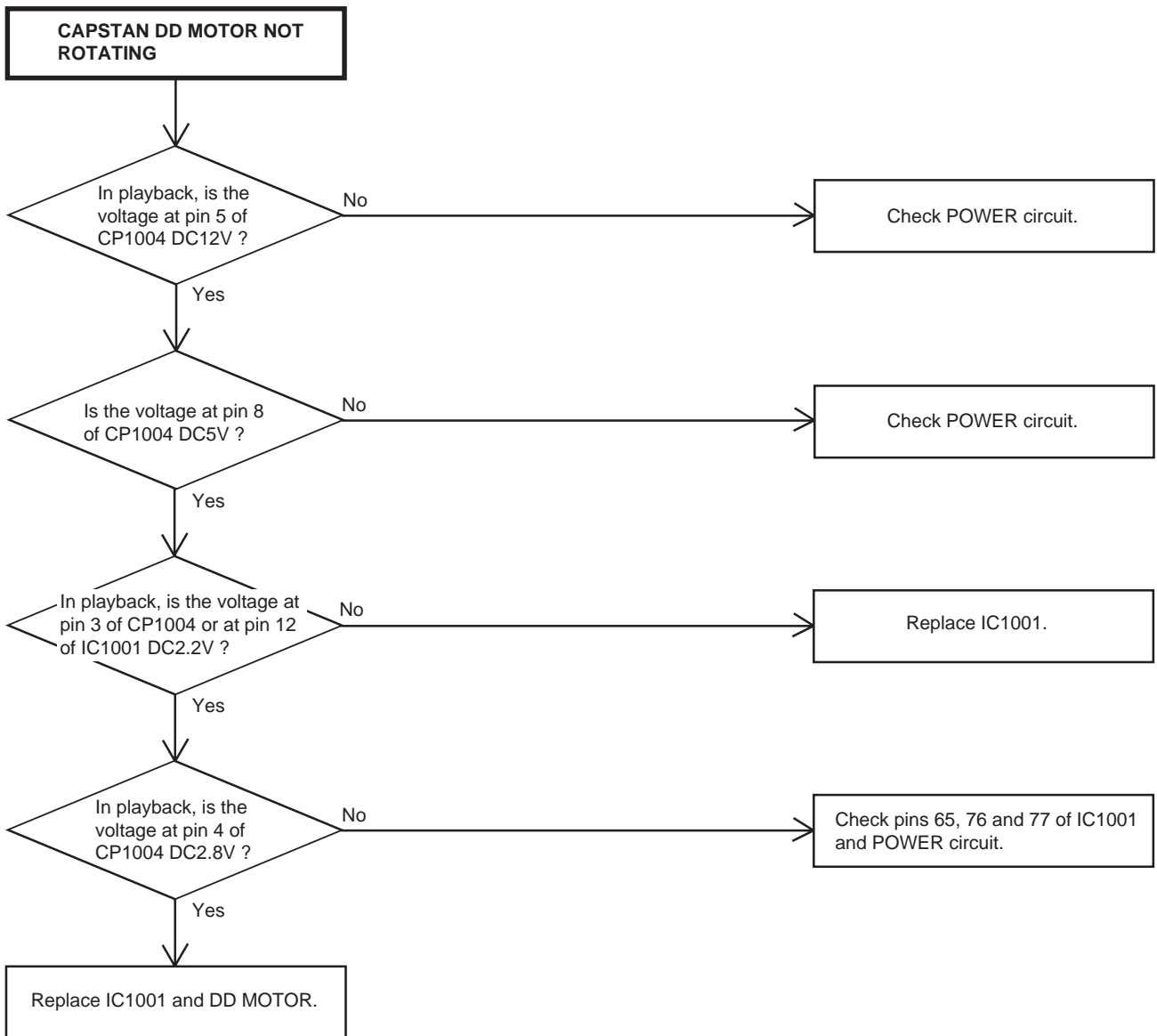

TROUBLESHOOTING GUIDE

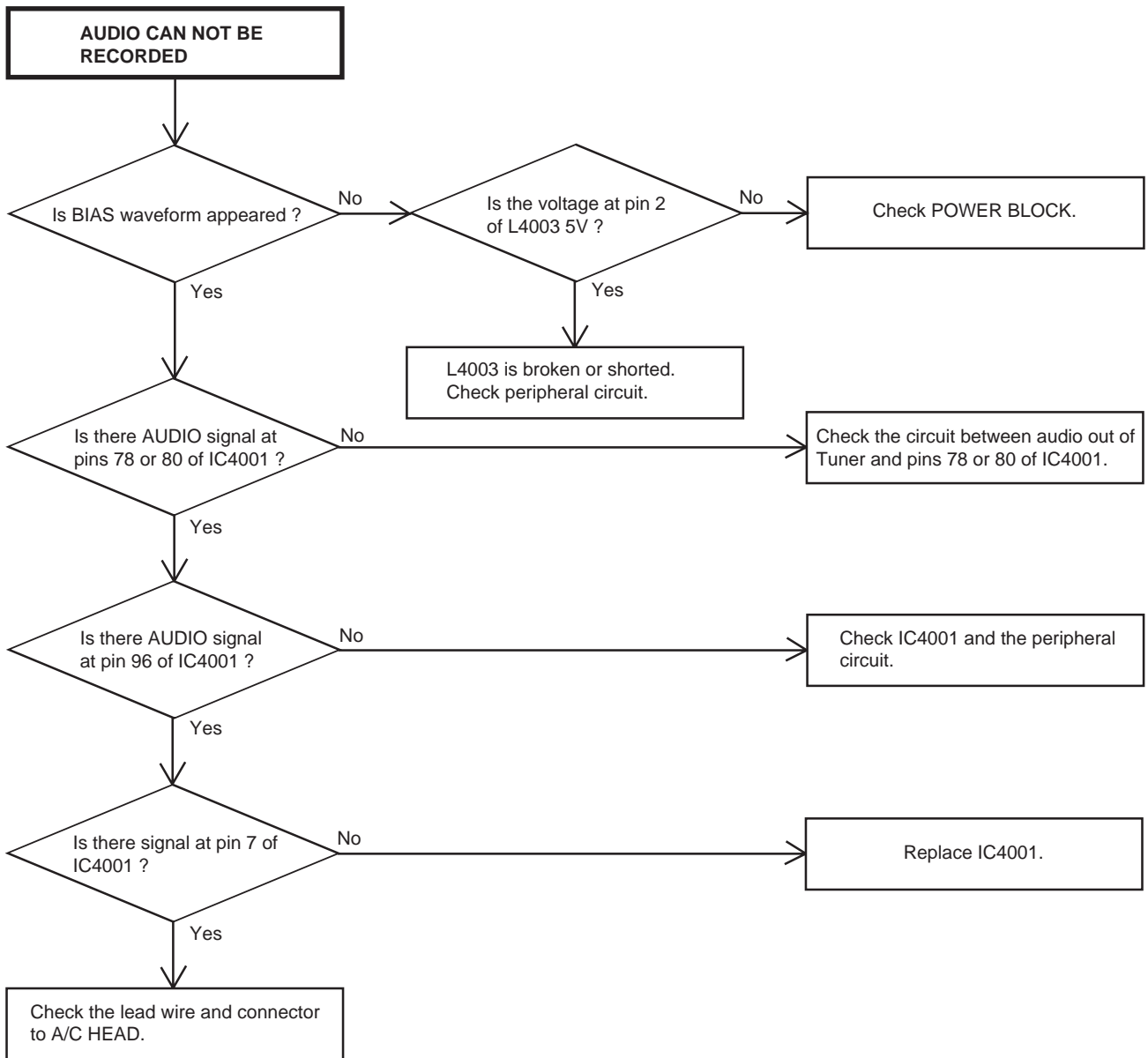

TROUBLESHOOTING GUIDE

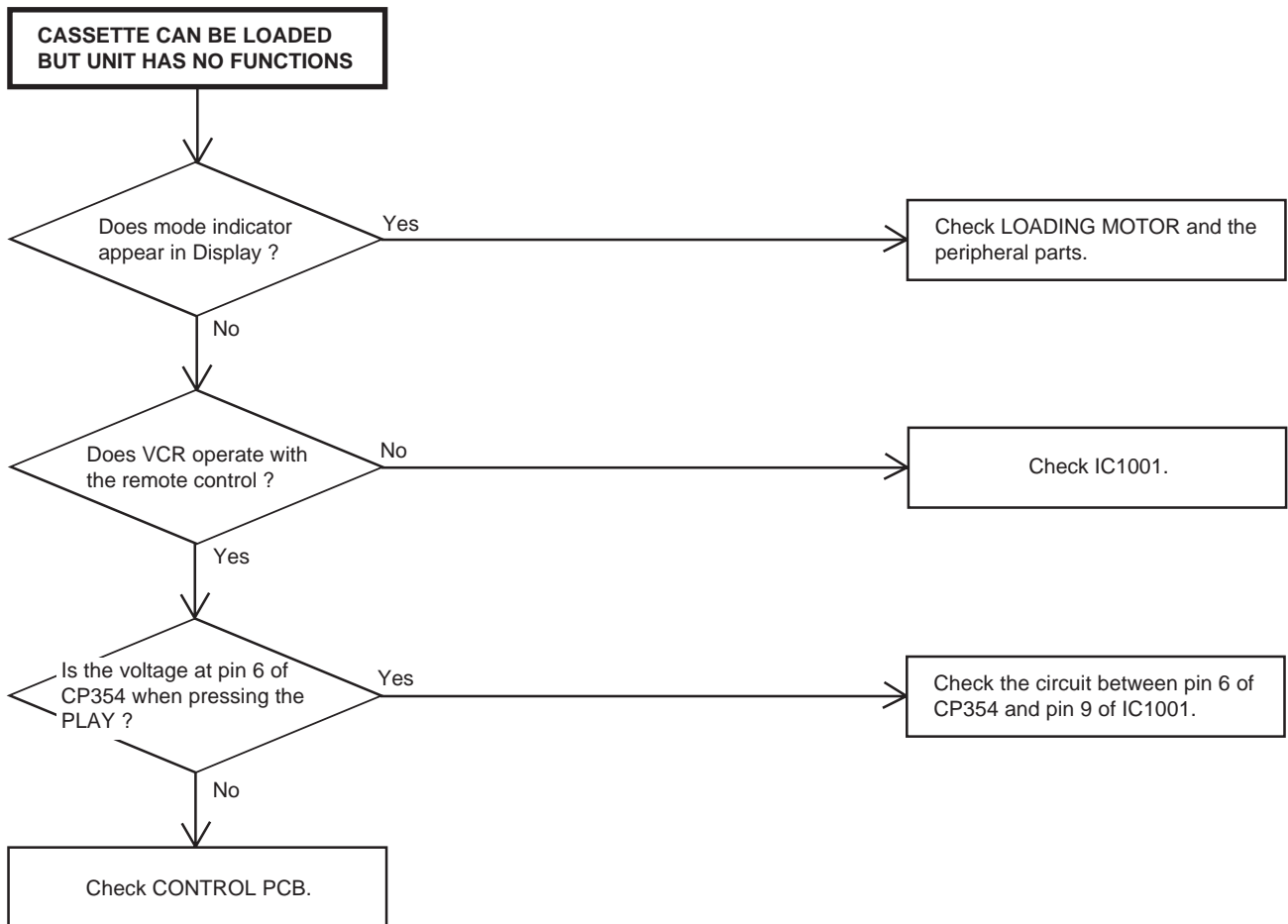

TROUBLESHOOTING GUIDE

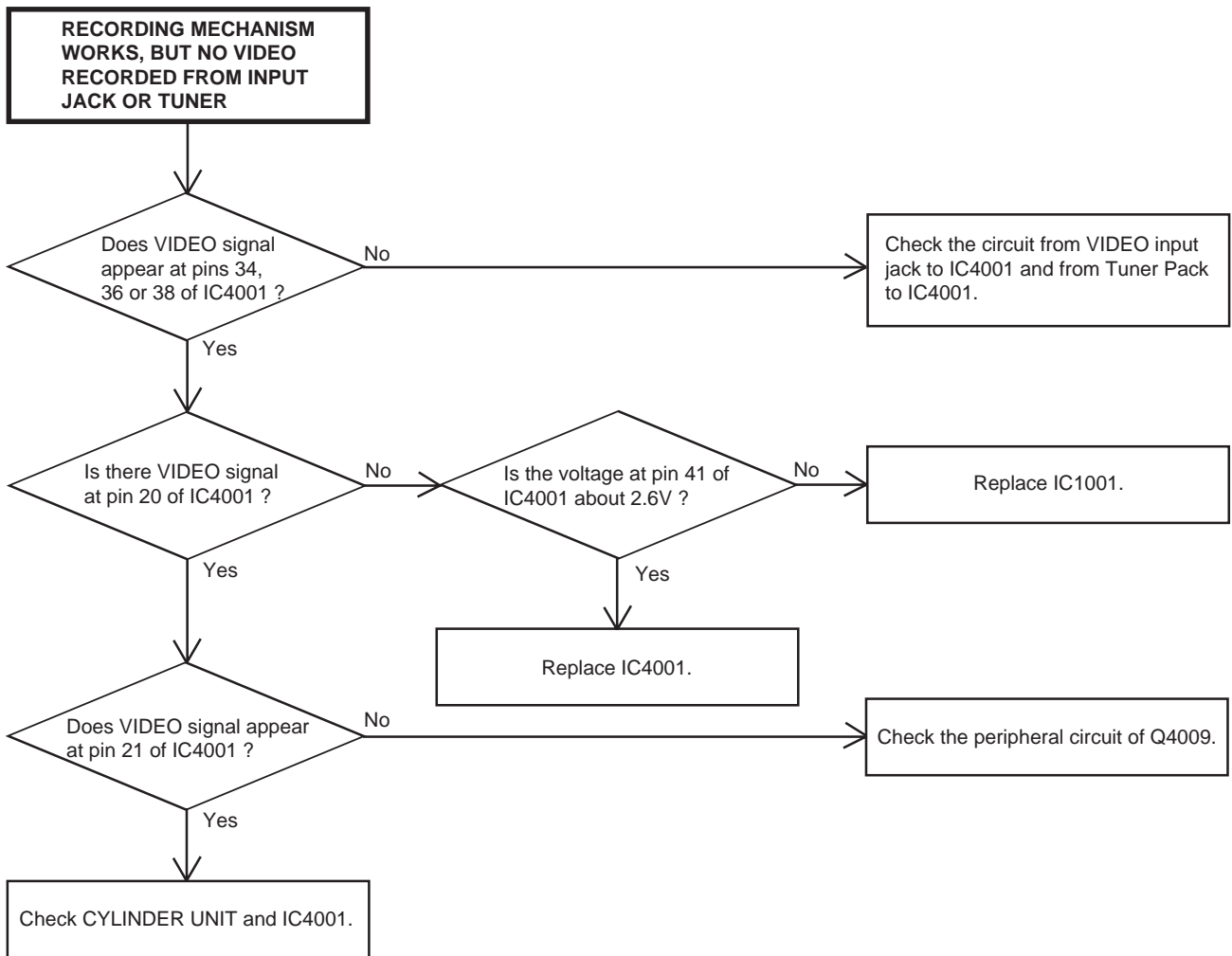

TROUBLESHOOTING GUIDE

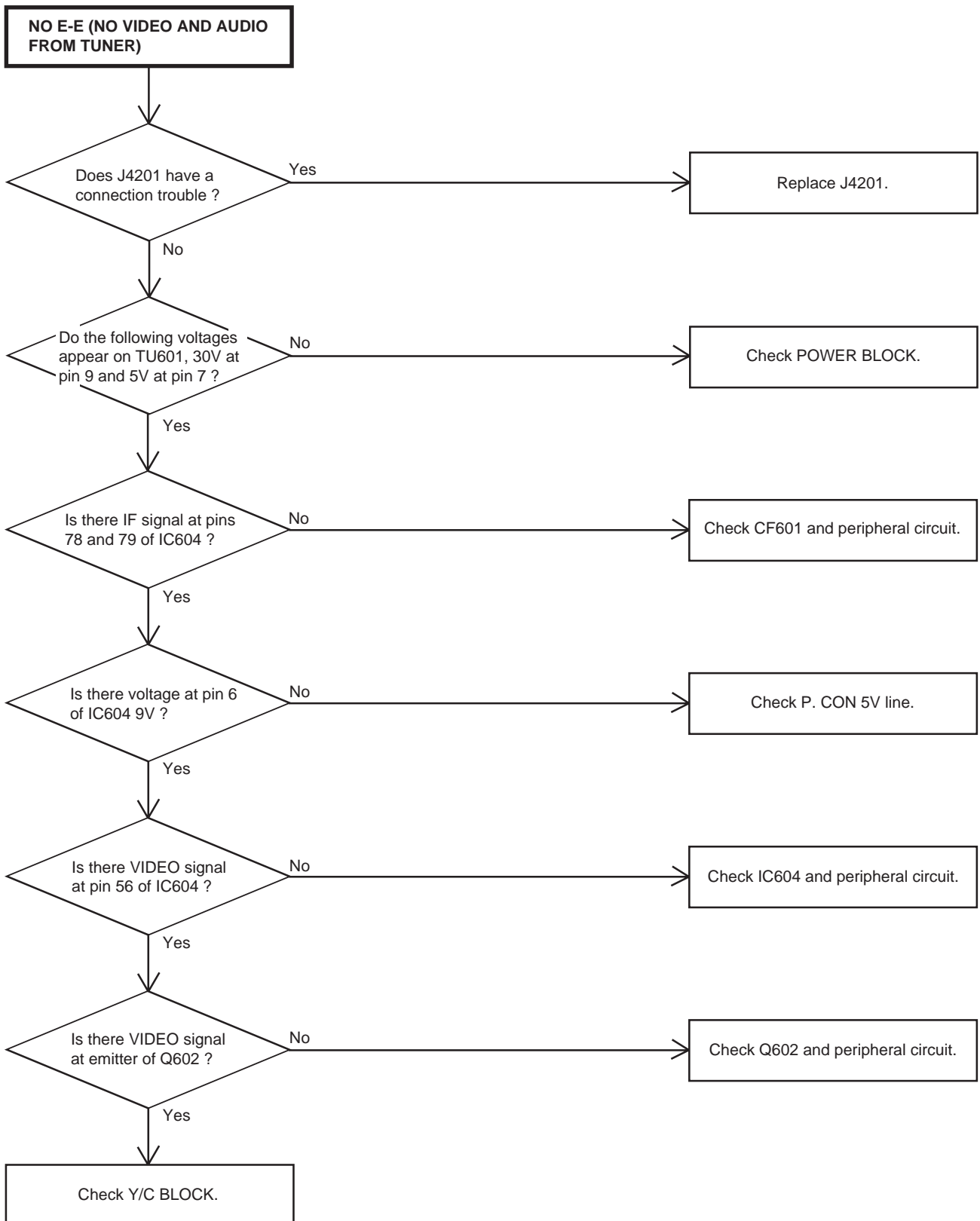

TROUBLESHOOTING GUIDE

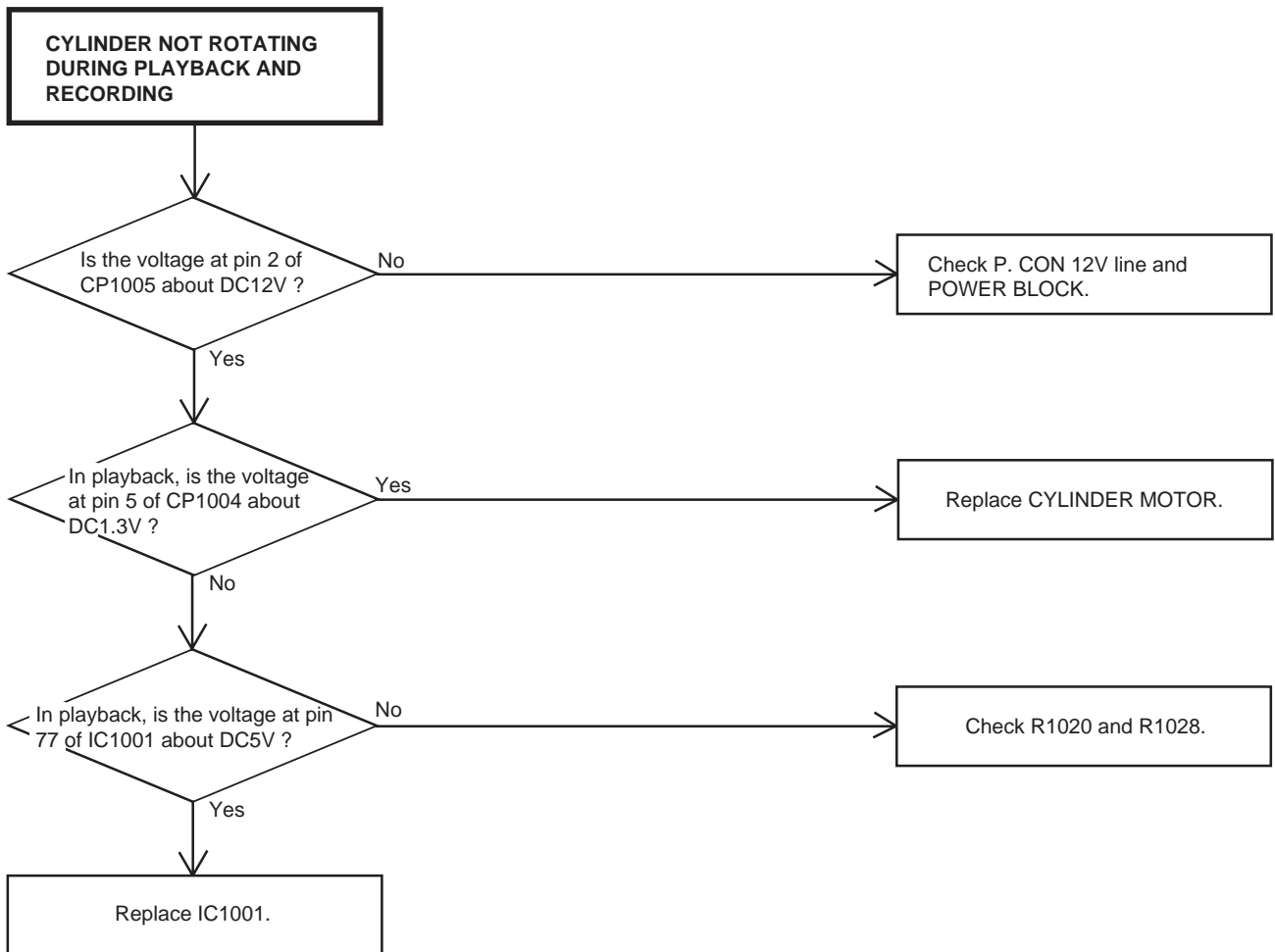

TROUBLESHOOTING GUIDE

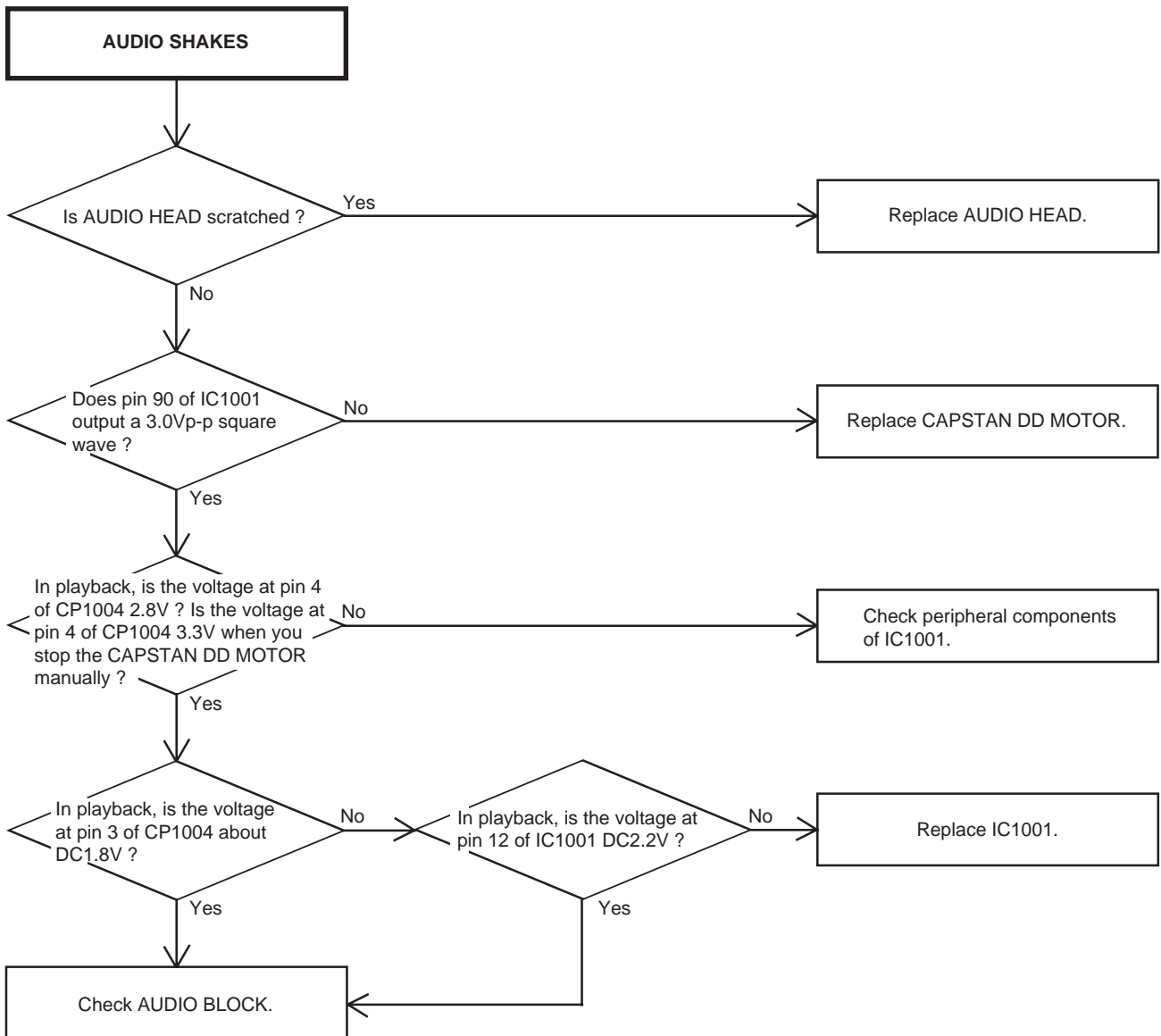

TROUBLESHOOTING GUIDE

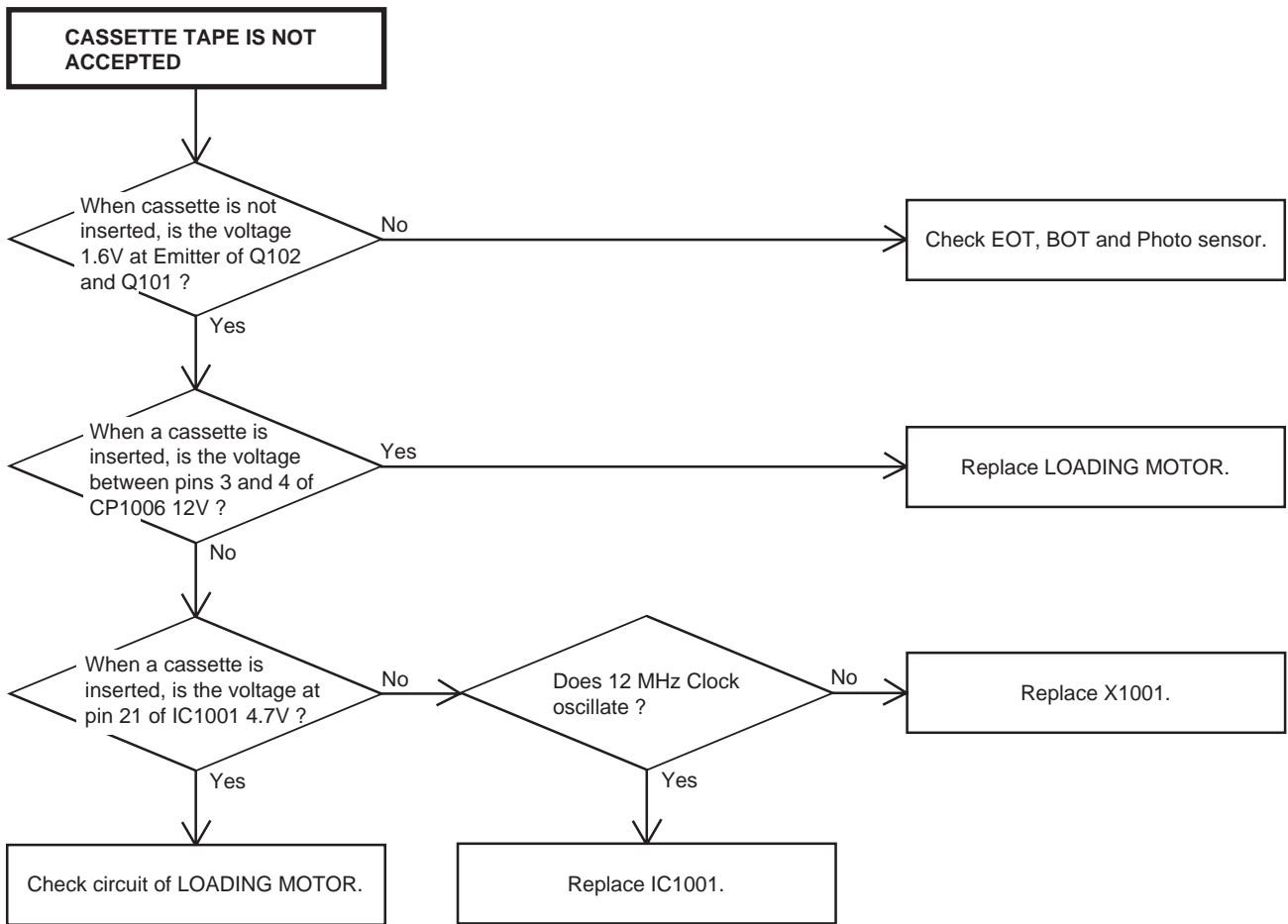

TROUBLESHOOTING GUIDE

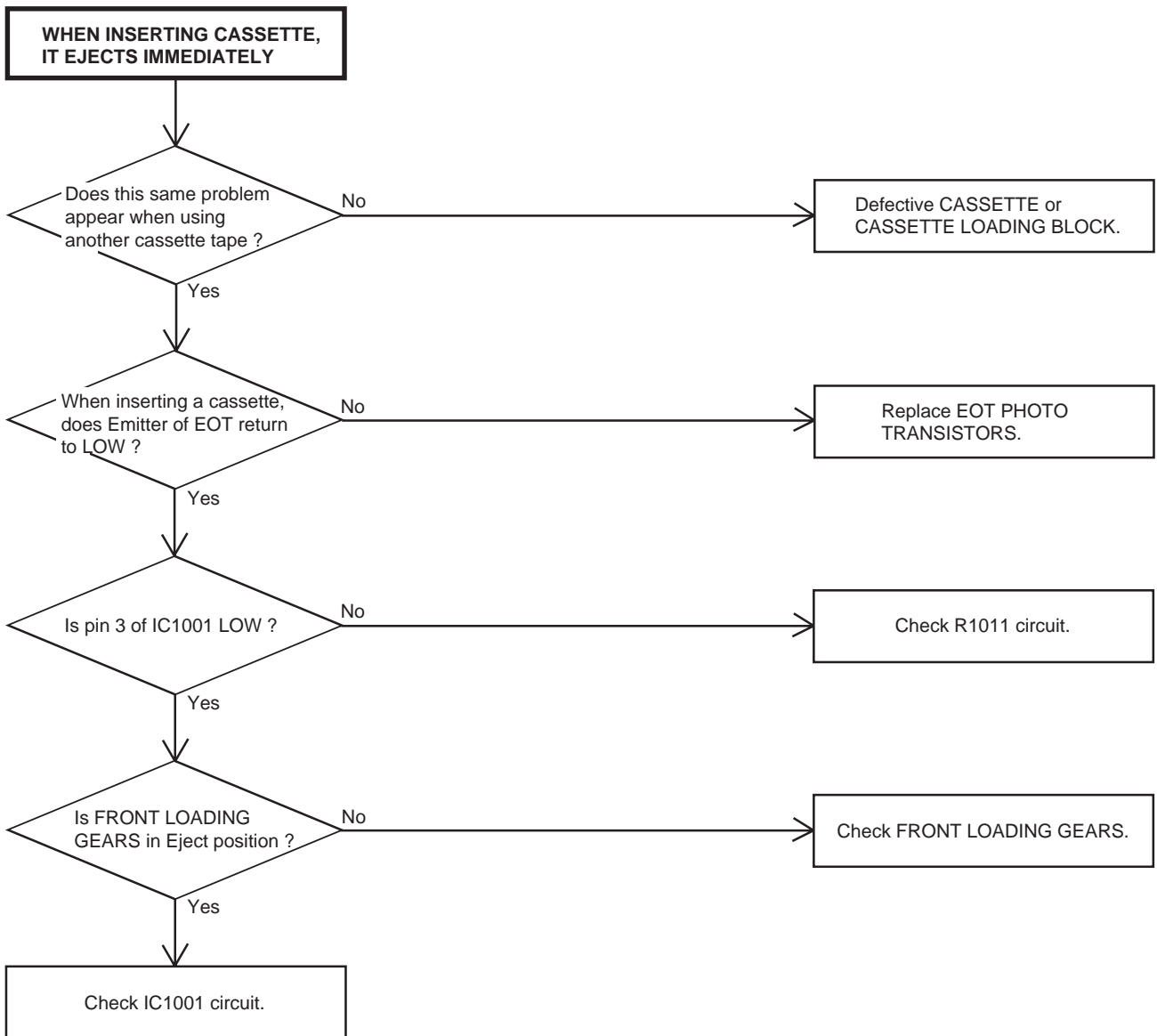

TROUBLESHOOTING GUIDE

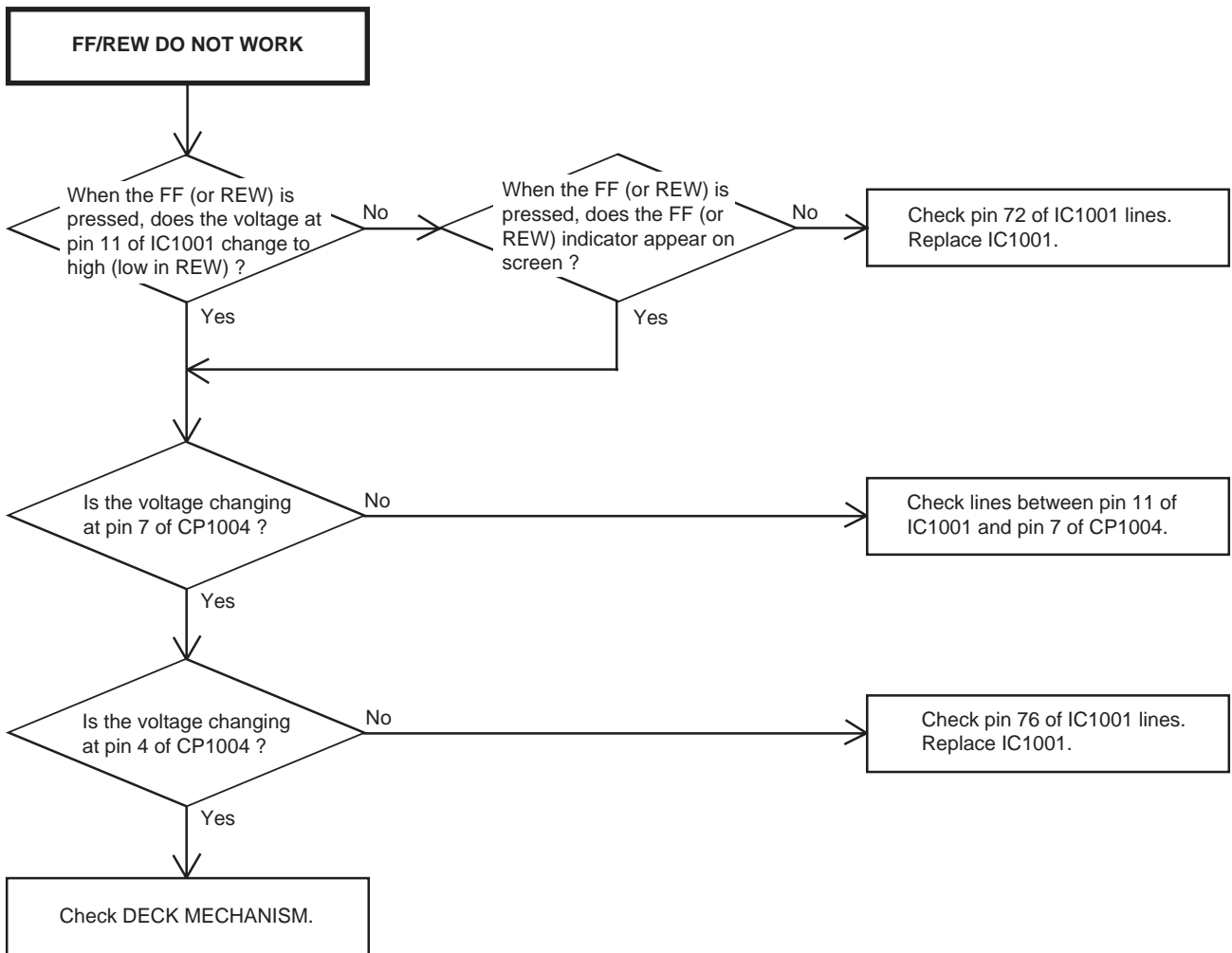

TROUBLESHOOTING GUIDE

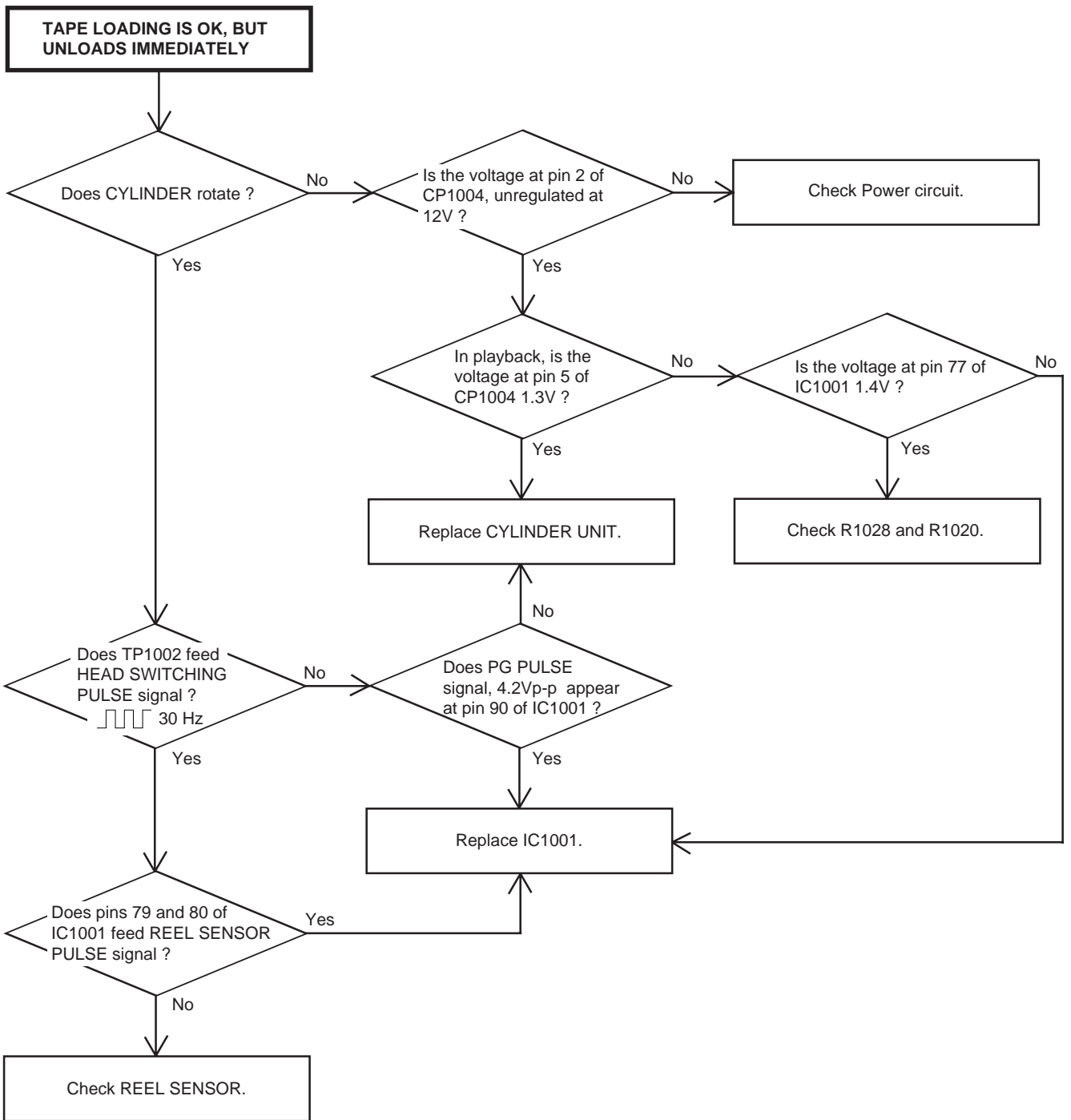

TROUBLESHOOTING GUIDE

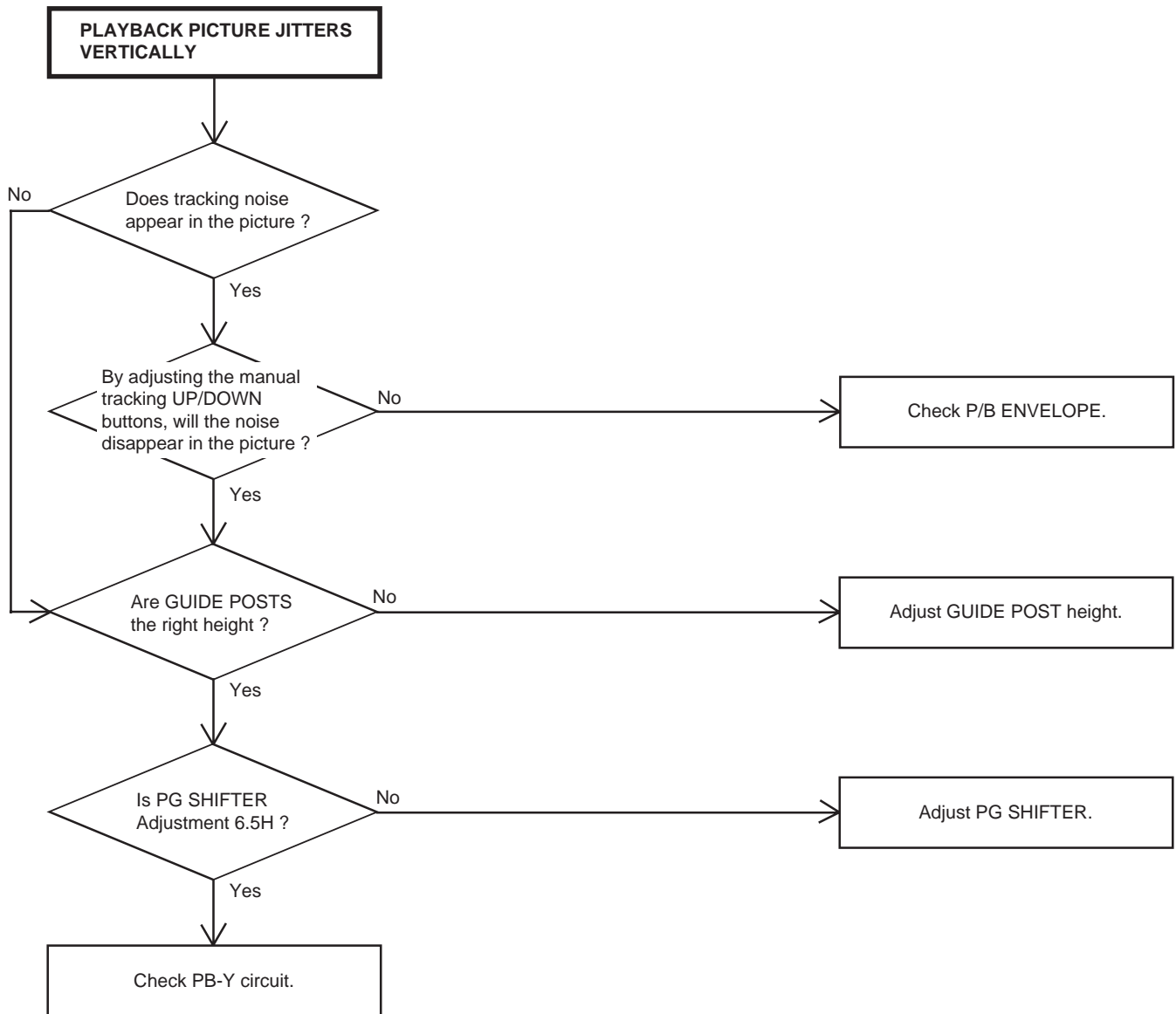

TROUBLESHOOTING GUIDE

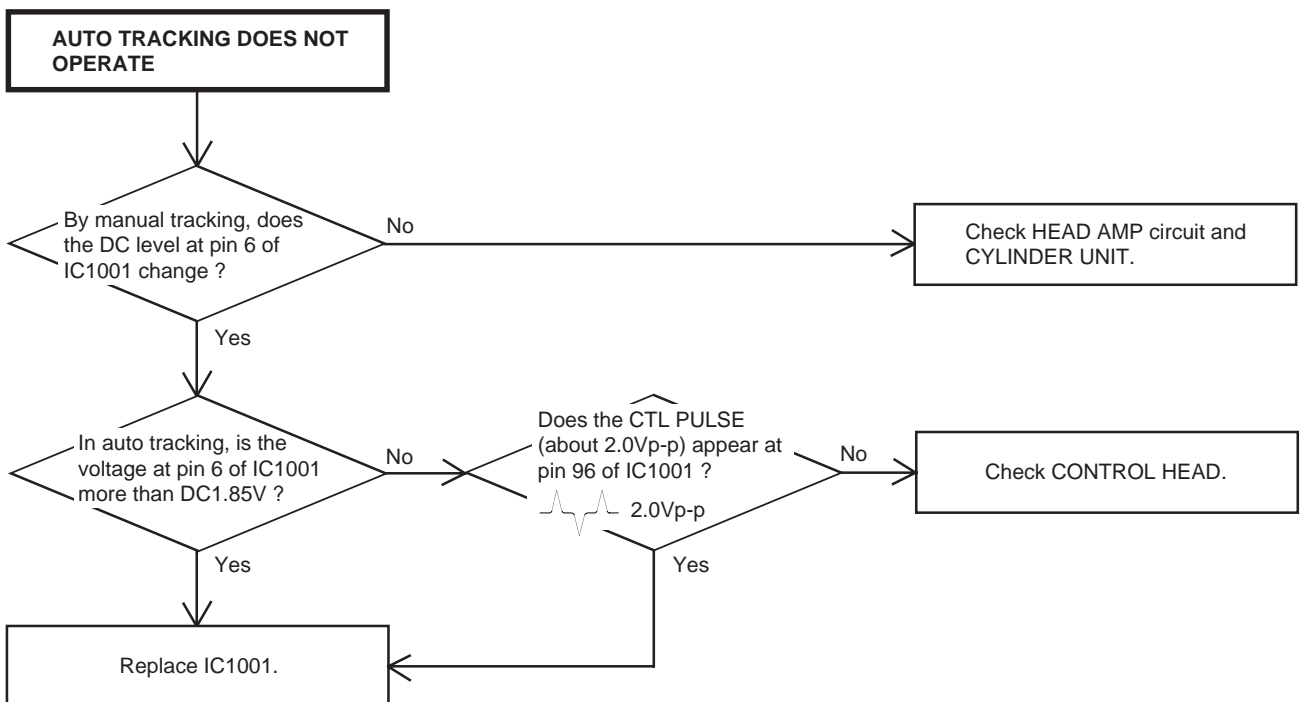
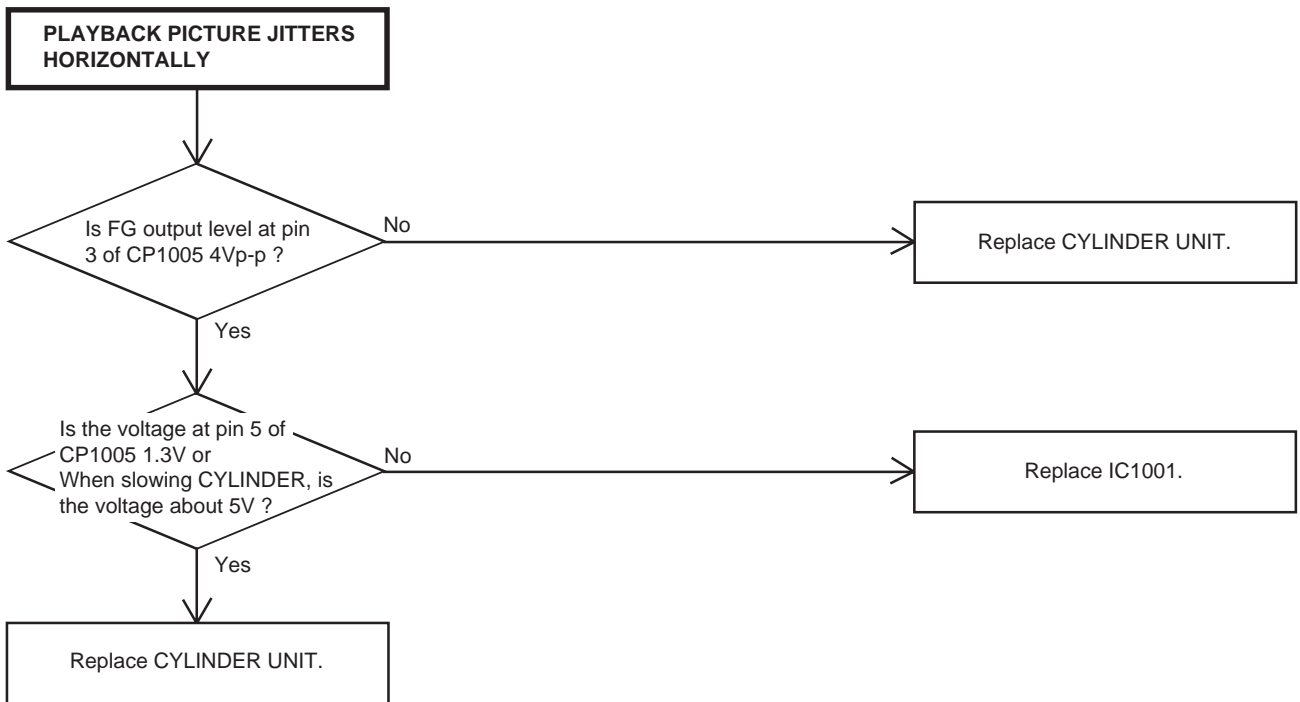

TROUBLESHOOTING GUIDE

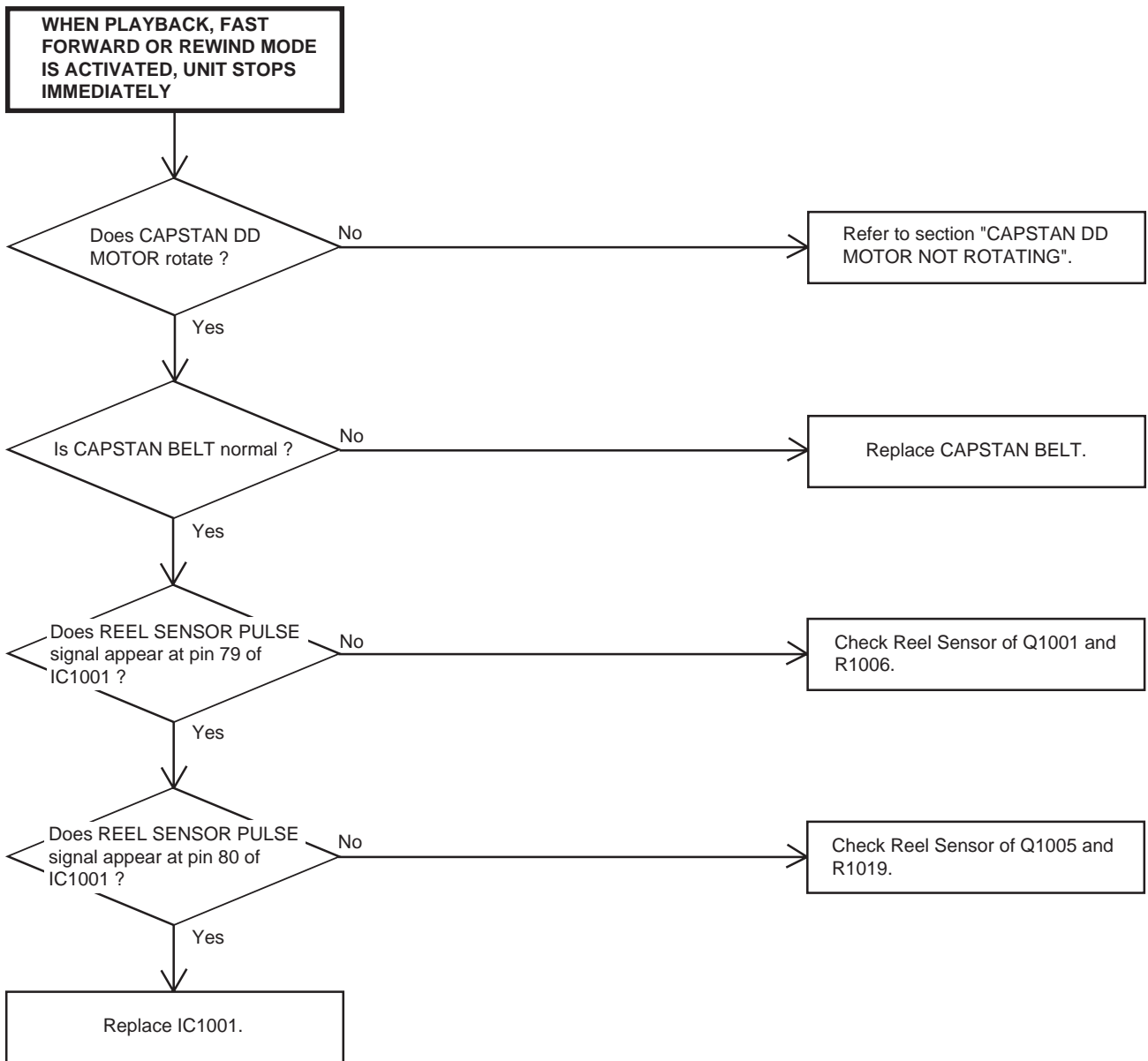

IC DESCRIPTION

OEC7041A (IC1001)

Pin No.	Pin Name	I/O	DESCRIPTION
1	MSEN-A	I	Input terminal of mecha state sensor.
2	MSEN-B	I	
3	EOT	I	Tape end sensor input signal.
4	BOT	I	Tape start sensor input signal.
5	HI-FI-ENV	I	Input terminal of HiFi RF envelope.
6	VIDEO-ENV	I	Input terminal of video RF envelope.
7	AFT(MONI)	I	Input terminal of AFT.
8	AFT(REC)	I	Not used.
9	KEY A	I	Main unit key input.
10	KEY B	I	
11	CAP-FWD	O	Capstan forward and backward command.(forward "L" output)
12	CAP-LIMIT	O	Switch the maximum output current of the Capstan Motor.
13	DUMMY-V.SYNC	O	Virtual V Pulse output.
14	REMOCON-IN	I	Receive the remote control signal.
15	COLOR ROTARY	O	Color Rotary Control output.
16	HEAD.AMP.SW	O	Switching output of Head Amp SW on 4 heads.
17	ENV-CMP-IN	I	Comparison results input of Playback Envelope level ON SP/LP heads(4heads).
18	VIDEO-H.SW	O	Output terminal of Head SW to Y/C/A and Head Amp.
19	HI-FI-H.SW	O	Output terminal of audio Head SW to Y/C/A and Head Amp.
20	LDM-RVS	O	Output signal to control the rotation direction of the loading motor.
21	LDM-FWD	O	
22	TRICK-PB-H	O	Special effect playback.(CUE/REVIEW/STILL/SLOW etc)
23	MSENS-CTL	O	MSEN sensor LED.
24	CAP-HI H	O	Power of Capstan Motor select.
25	PLAY LED	O	PLAY indication LED output.
26	EXT-MUTE	O	Mute signal of external video mute.
27	VCR-POWER	O	VCR power output.
28	TV-POWER	O	TV power output.
29	T-REC LED	O	T-REC indication LED output.
30	REC LED	O	REC indication LED output.
31	ON-TIMER LED	O	ON-TIMER indication LED output.
32	OTPB LED	O	OTPB indication LED output.
33	AKB CTL	O	"H" is output at the time of AKB white adjustment.
34	RESET-L	I	RESET will be done when the voltage goes to HIGH after the reset signal.
35	XC_IN(32kHz)	I	Subclock pulse.(32kHz)
36	XC_OUT(32kHz)	O	
37	VCC	-	5V
38	X-IN(12MHz)	I	Connect the main crystal.(10MHz)
39	X-OUT(12MHz)	O	
40	VSS	-	Ground.
41	AV1	O	Not used.
42	AV2	O	Not used.
43	CLKSEL	I	5V
44	OSC-IN2	I	Condenser connection for OSC-IN2.

IC DESCRIPTION

OEC7041A (IC1001)

Pin No.	Pin Name	I/O	DESCRIPTION
45	OSC-OUT2	O	Condenser connection for OSC-OUT2.
46	NUB	-	Ground.
47	CM_ADV_VIDEO	I/O	Not used.
48	CM_ADV_AUDIO	I	Not used.
49	OSD-VSS	-	Ground.
50	TAB SW	I	Input terminal for judge the tape if it has TAB or not.
51	SERVICE	I	Input terminal for Service Mode.
52	SD-IN(MONI)	I	Not used.
53	OSD-VCC	-	5V
54	HLF	-	Condenser connection for HLF.
55	VHOLD	-	Condenser connection for VHOLD.
56	CVIN	I	Composite Video input terminal.
57	NUA	-	Ground.
58	H/C-SYNC	I	Input terminal for H-SYNC.
59	V-SYNC	I	Input terminal for V-SYNC.
60	OSD OUT1	O	Blanking output terminal of OSD.
61	CENTER LED	O	Tape end sensor LED.
62	B	O	Color signal blue output.
63	G	O	Color signal green output.
64	R	O	Color signal red output.
65	CAP FULL	O	Output the HIGH during the acceleration force of capstan motor at SLOW mode.
66	V-REC-ST-H	O	On control of A/V recording (Whole width erase) circuit.
67	IIC-CLK3	O	Not used.
68	IIC-DATA3	I/O	Not used.
69	SP-H	O	Output "H" terminal of Playback/Recording SP mode.
70	IIC-DATA2	I/O	Terminal for I2C BUS communication.
71	IIC-CLK1	O	CLOCK terminal for I2C BUS communication.
72	IIC-DATA1	I/O	DATA terminal for I2C BUS communication.
73	IIC-OFF	I	When input "L" the I2CBUS communication is stopped.
74	JUST CLOCK	I	Not used.
75	AGC(REC)	O	Not used.
76	CAP-PWM	O	PWM putput of Capstan control.
77	DRUM-PWM	O	PWM putput of Cylinder control.
78	E/V_MASK	I	Not used.
79	REEL-S	I	Input terminal of reel sensor supply.
80	REEL-T	I	Input terminal of reel sensor take up.
81	VCR_A_MUTE	O	Mute signal of audio mute.(VCR)
82	TV_A_MUTE	O	Mute signal of audio mute.(TV)
83	FF/REW-L	O	The output terminal of to that switches the frequency characteristic of CTL by the circuit bill outside.
84	CA/MA_SEL	O	Not used.
85	POWER_FAIL_L	I	Input for the detection of power interruption.
86	CFG AMP-OUT	O	Not used.
87	CAP-FG	I	Input terminal for capstan rotation signal detection.

IC DESCRIPTION

OEC7041A (IC1001)

Pin No.	Pin Name	I/O	DESCRIPTION
88	AMP-VSS	-	Ground.
89	DRUM-FG	I	Input terminal for drum rotation signal detection.
90	DRUM-PG	I	Input terminal for DRUM PG signal detection.
91	AMP-VREFOUT	O	Condenser connection for AMP-VREFOUT.
92	AMP-VREFIN	I	Condenser connection for AMP-VREFIN.
93	C	I	Condenser connection for C.
94	CTL-	I/O	Input and output terminal of Control Head.
95	CTL+	I/O	Input terminal of Control Head.
96	AMP C	-	Condenser connection for AMP C.
97	CTL AMP-OUT	O	Output terminal for amp out.
98	AMP-VCC	-	5V
99	ANALOG VCC	-	5V
100	DEW(mono)	I	Input terminal for the detection with the dew of the cylinder.
100	STEREO SEL(HiFi)	I	Input terminal for the judgement of voice reception condition.

- The assignment for Pin 100 is varies according to the SET which is MONO or Hi-Fi.
It is used for DEW terminal in MONO and STEREO SEL terminal in Hi-Fi.

SERVO TIMING CHART

IC1001 (OEC7041A)

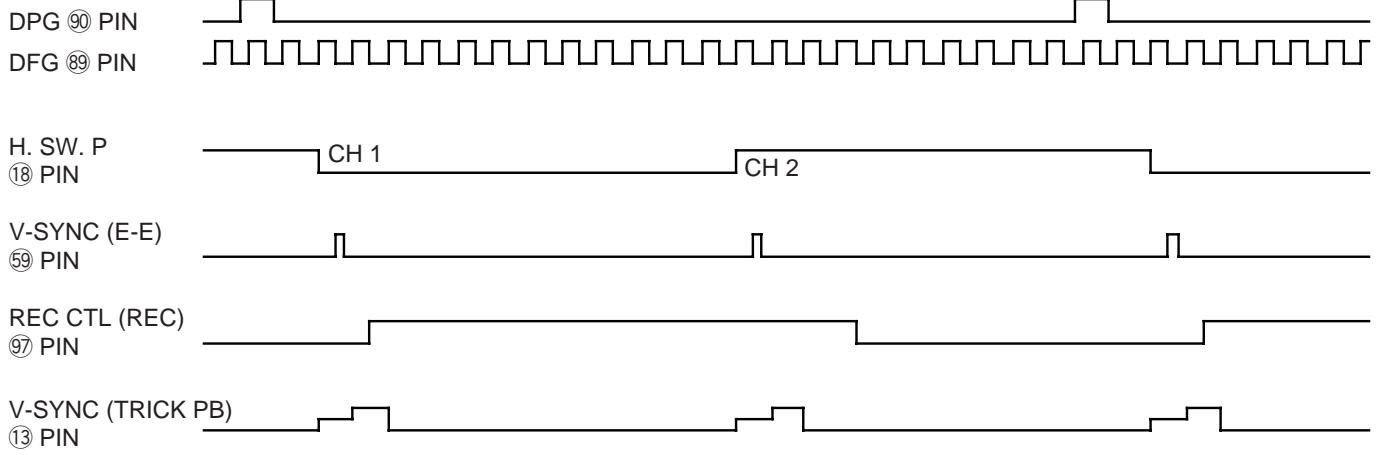

• WAVEFORM CHANGES DEPENDED ON THE TAPE SPEED

SYSTEM SWITCH MODE

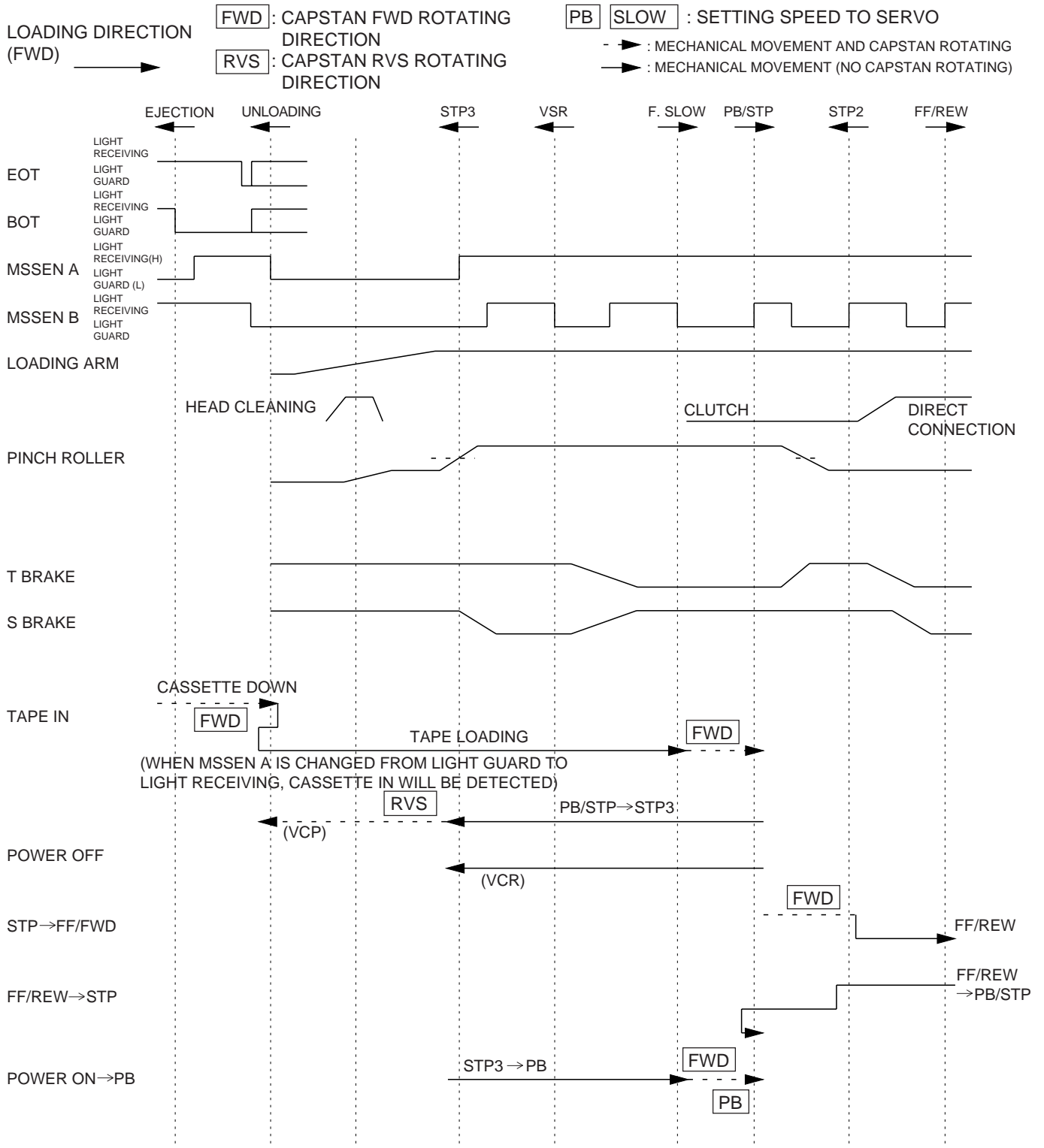

SEMICONDUCTOR BASE CONNECTIONS

DIODE

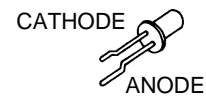

1SS133T-77
HZ11B3L TD
HZ27-1L TD
HZ30-1L TD
HZ6A3L TD
MTZJ5.1B T-77
MTZJ5.6B T-77
MTZJ6.8B T-77
MTZJ9.1B T-77
SB10-03A3

11E1N-TA1B2
11EQS04N-TA1B2
11ES1N-TA1B2
1N4005E-G23
RD12FB-T7
RMPG06J

21DQ09N-TA2B1
RM11C
RU2AM V1

SID1050CM

EM-553-F1T
EQ-552-F1T

IC

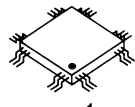

100PIN
LA71170M-MPB

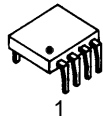

8PIN
S-24C04BDP-LA

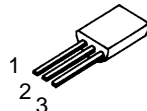

3PIN
PST600H

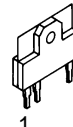

7PIN
LA7840

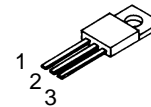

3PIN
KIA7806PI
KIA7812PI

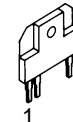

9PIN
AN7523

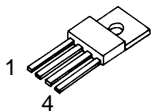

4PIN
PQ09RD08



4PIN
TLP621(D4-GR-LF2)

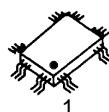

80PIN
LA76814BM-MPB
100PIN
OEC7041A

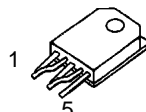

5PIN
STR-F6612

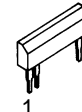

8PIN
BA6955AN

TRANSISTOR

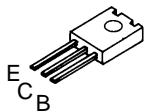

2SC4217(D,E)-RAC

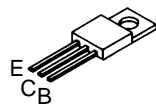

2SD2396(J,K)



GP1S94L

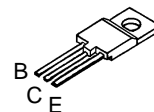

2SD2599

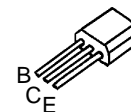

DTC114TSTP

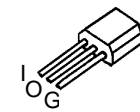

DTC114ESTP

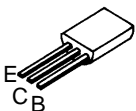

2SA1318(S,T)-AA
2SA1371(D,E)-AE
2SA733(C)-T_Q
2SC1317(Q,R,S)-T
2SC1815Y(TPE2)
2SC2271(D,E)-AE
2SC2909(S,T)-AA
2SC3331(S,T,U)-A
2SC945(C)-T(P,Q)

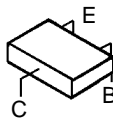

2SA1037AKT146R,S
2SC2412KT146 R,S
DTC114TKAT146

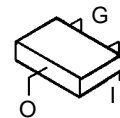

DTA114EKAT146
DTA124EKAT146
DTC114EKAT146
DTC124EKAT146
DTC143EKAT146

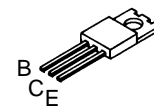

2SB1134R
2SC4160-OEC-YAC1

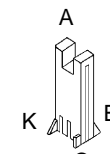

GP1S566
SG-260

TV BLOCK DIAGRAM

- ◀ R. SIGNAL
- ◀ G. SIGNAL
- ◀ B. SIGNAL
- ◀ COLOR SIGNAL
- ◀ LUMINANCE SIGNAL
- ◀ TUNER VIDEO SIGNAL
- ◀ AUDIO SIGNAL
- ◀ DEFLECTION SIGNAL
- ◀ TUNER AUDIO SIGNAL

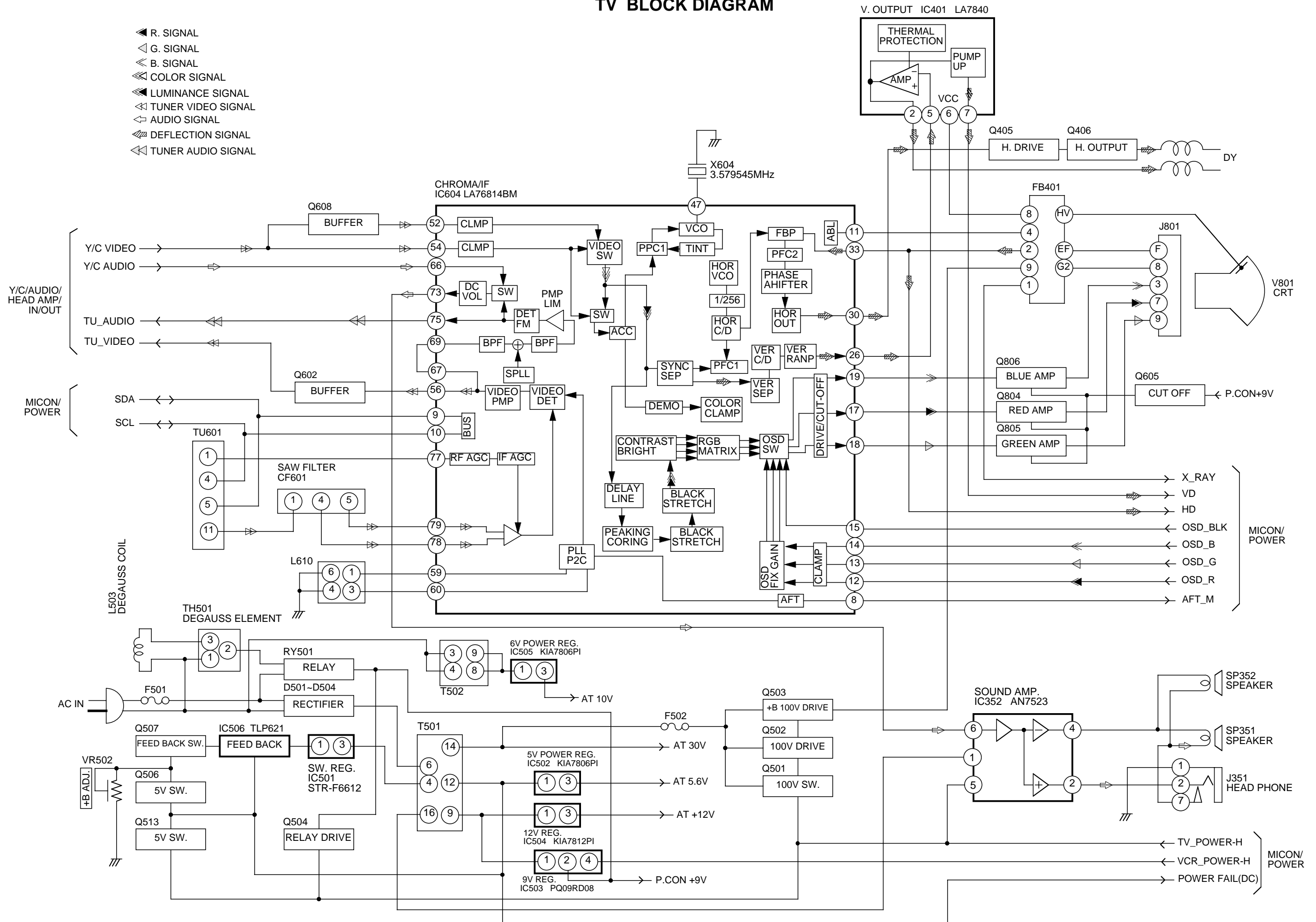

Y/C/AUDIO/HEAD AMP/IN/OUT BLOCK DIAGRAM

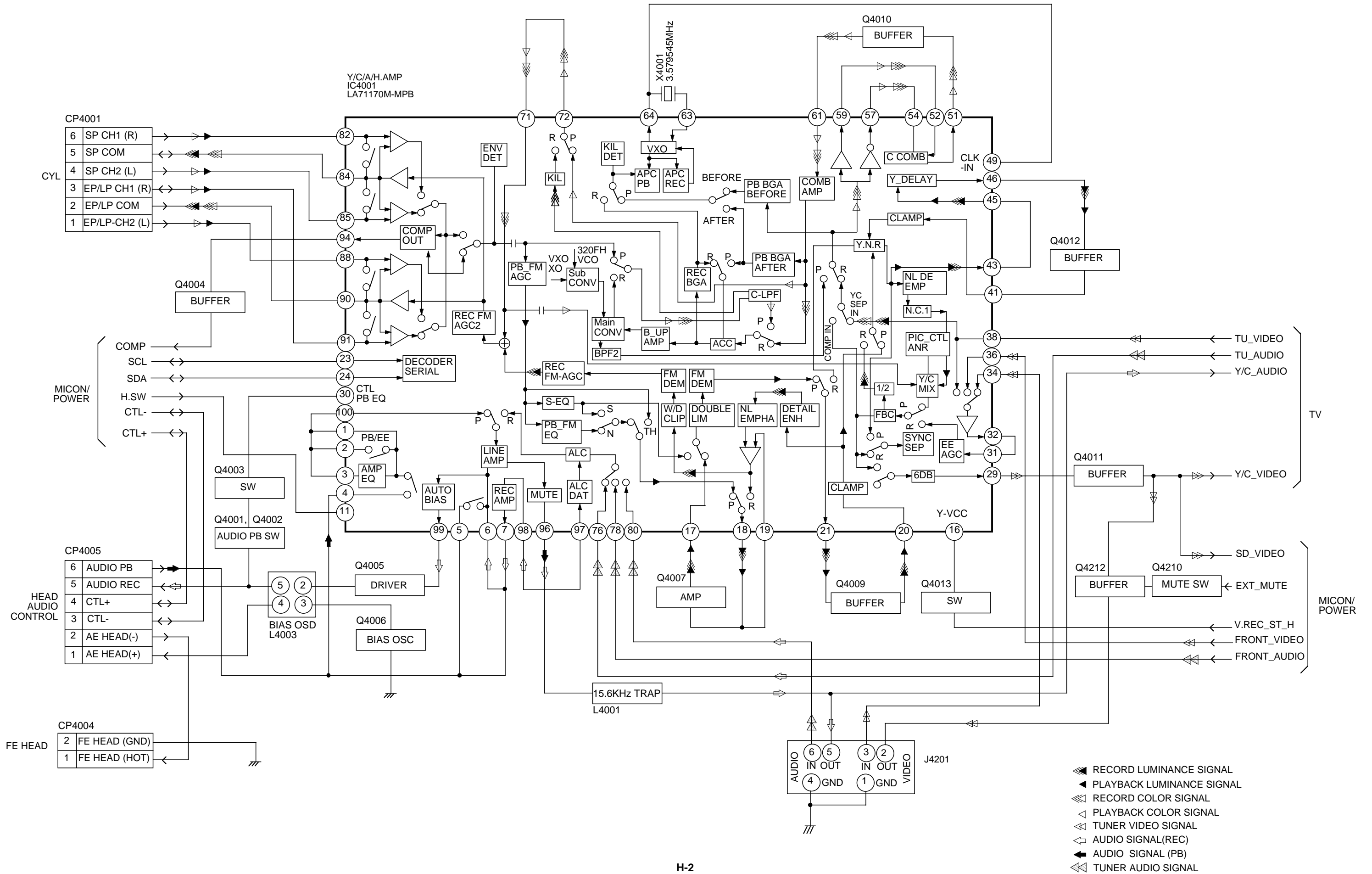

MICON/POWER/OPERATION BLOCK DIAGRAM

TIMER SYSCON MICON
IC1001 OEC7041A

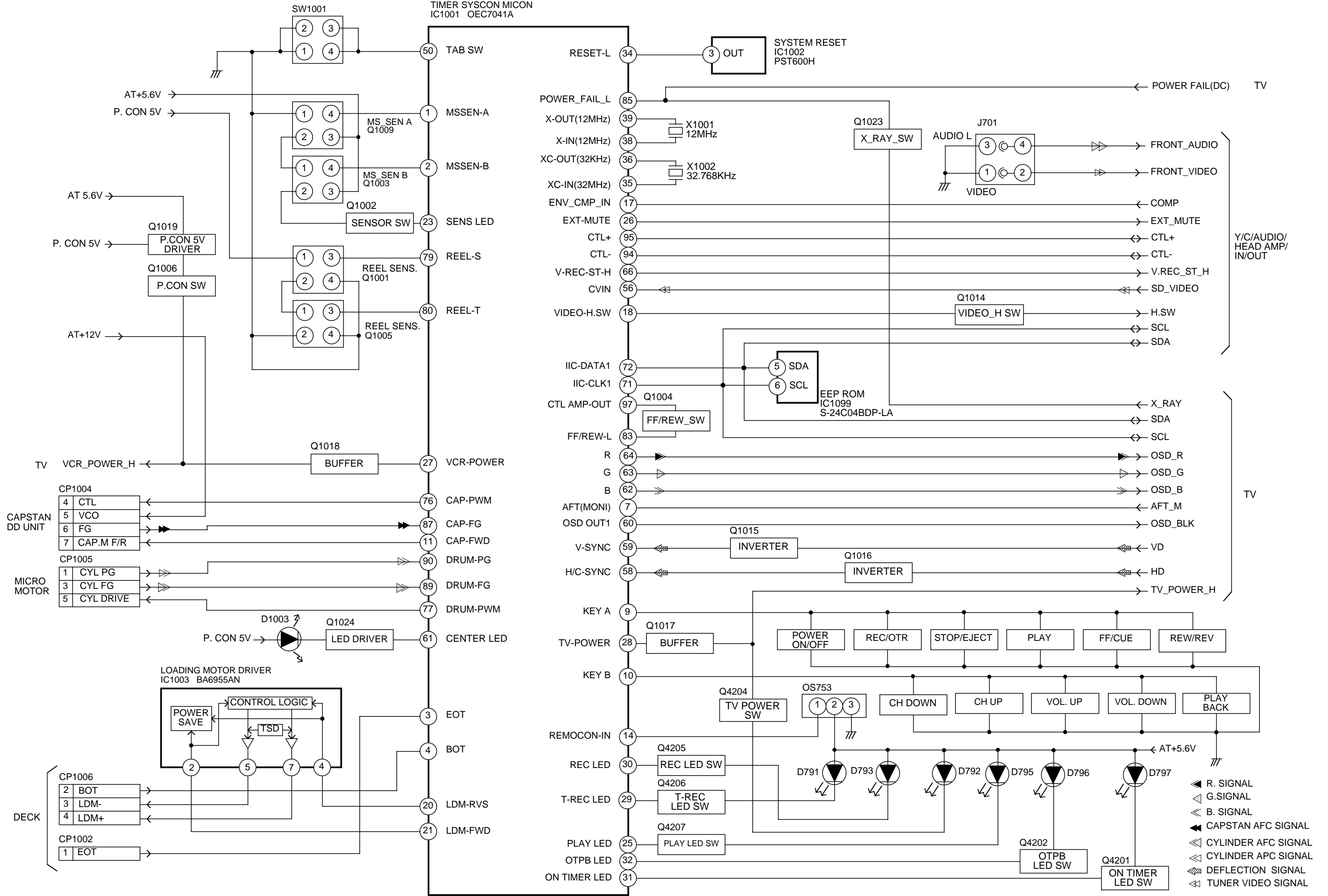

PRINTED CIRCUIT BOARDS

OPERATION SOLDER SIDE

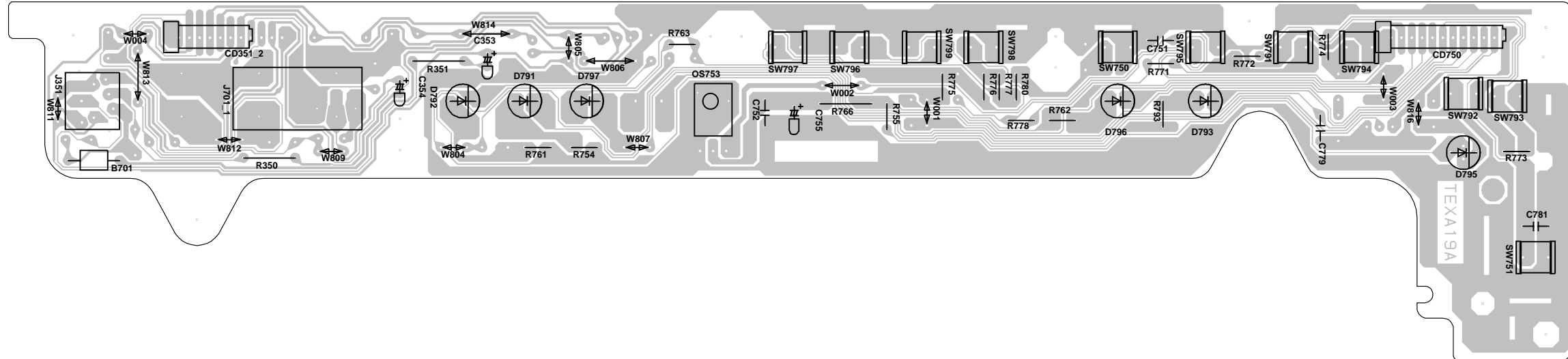

DECK SOLDER SIDE

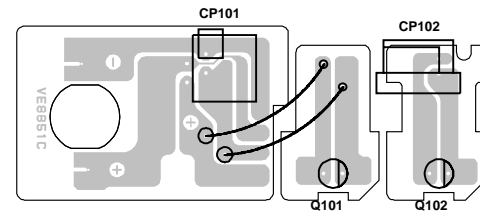

OPERATION SCHEMATIC DIAGRAM (OPERATION PCB)

FROM/TO I/O

1	REMOCON OUT
2	GND
3	AT+5V
4	POWER ON L
5	OTP/PLAY LED
6	KEY A
7	T-REC LED
8	REC LED
9	KEY B
10	ON TIMER LED
11	PLAY LED

FROM/TO I/O

1	FRONT VIDEO IN
2	GND
3	FRONT AUDIO IN
4	SOUND GND
5	SOUND OUT
6	SP OUT
7	GND

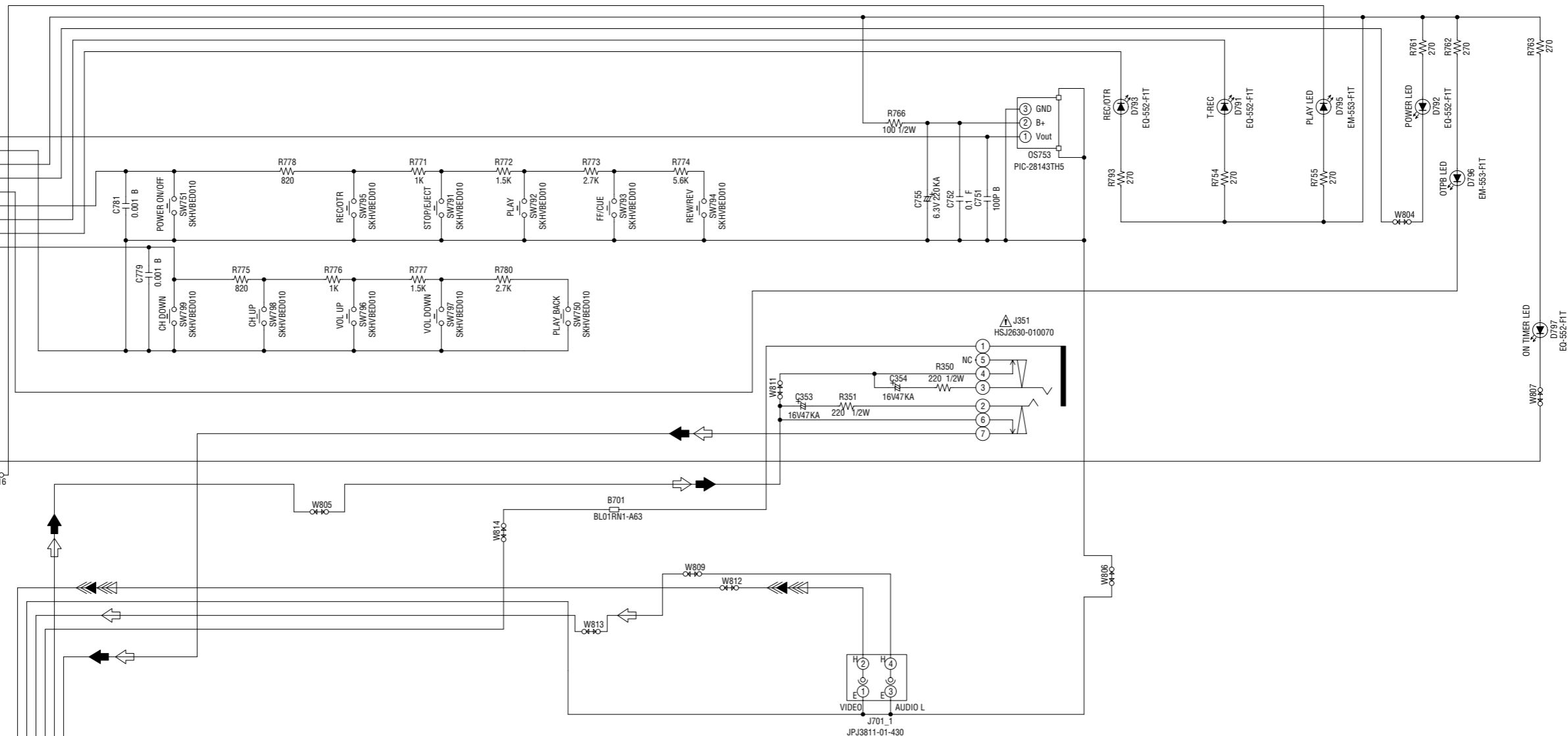

- ◁ AUDIO SIGNAL (REC)
- ▶ AUDIO SIGNAL (PB)
- ◁ RECORD LUMINANCE SIGNAL
- ◁ RECORD COLOR SIGNAL

NOTE: THIS SCHEMATIC DIAGRAM IS THE LATEST AT THE TIME OF PRINTING AND SUBJECT TO CHANGE WITHOUT NOTICE.

NOTE: THE DC VOLTAGE AT EACH PART WAS MEASURED WITH THE DIGITAL TESTER WHEN THE COLOR BROADCAST WAS RECEIVED IN GOOD CONDITION AND PICTURE IS NORMAL.

CAUTION: SINCE THESE PARTS MARKED BY ARE CRITICAL FOR SAFETY, USE ONES DESCRIBED IN PARTS LIST ONLY.

ATTENTION: LES PIÈCES REPARÉES PAR UN ÉTANT DANGEREUSES AN POINT DE VUE SECURITE N'UTILISER QUE CELLS DECRITES DANS LA NOMENCLATURE DES PIÈCES.

PCB030
TEXA19

DECK SCHEMATIC DIAGRAM

(DECK PCB)

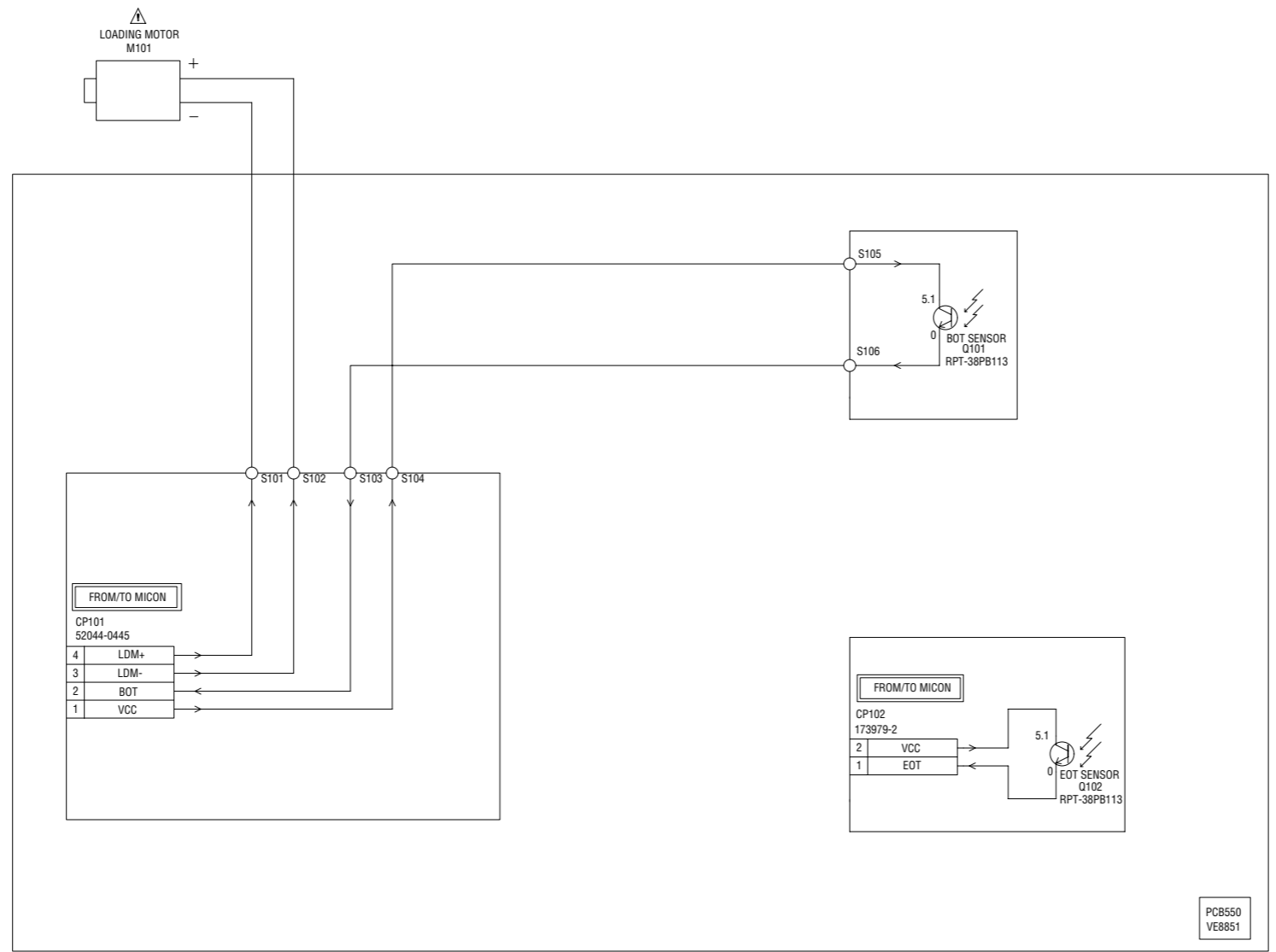

CAUTION: SINCE THESE PARTS MARKED BY ARE CRITICAL FOR SAFETY, USE ONES DESCRIBED IN PARTS LIST ONLY.

ATTENTION: LES PIÈCES RÉPARÉES PAR UN ÉTANT DANGEREUSES AN POINT DE VUE SÉCURITÉ, N'UTILISER QUE CELLES DÉCRITES DANS LA NOMENCLATURE DES PIÈCES.

NOTE: THE DC VOLTAGE AT EACH PART WAS MEASURED WITH THE DIGITAL TESTER DURING PLAYBACK.

NOTE: THIS SCHEMATIC DIAGRAM IS THE LATEST AT THE TIME OF PRINTING AND SUBJECT TO CHANGE WITHOUT NOTICE.

PRINTED CIRCUIT BOARDS SYSCON

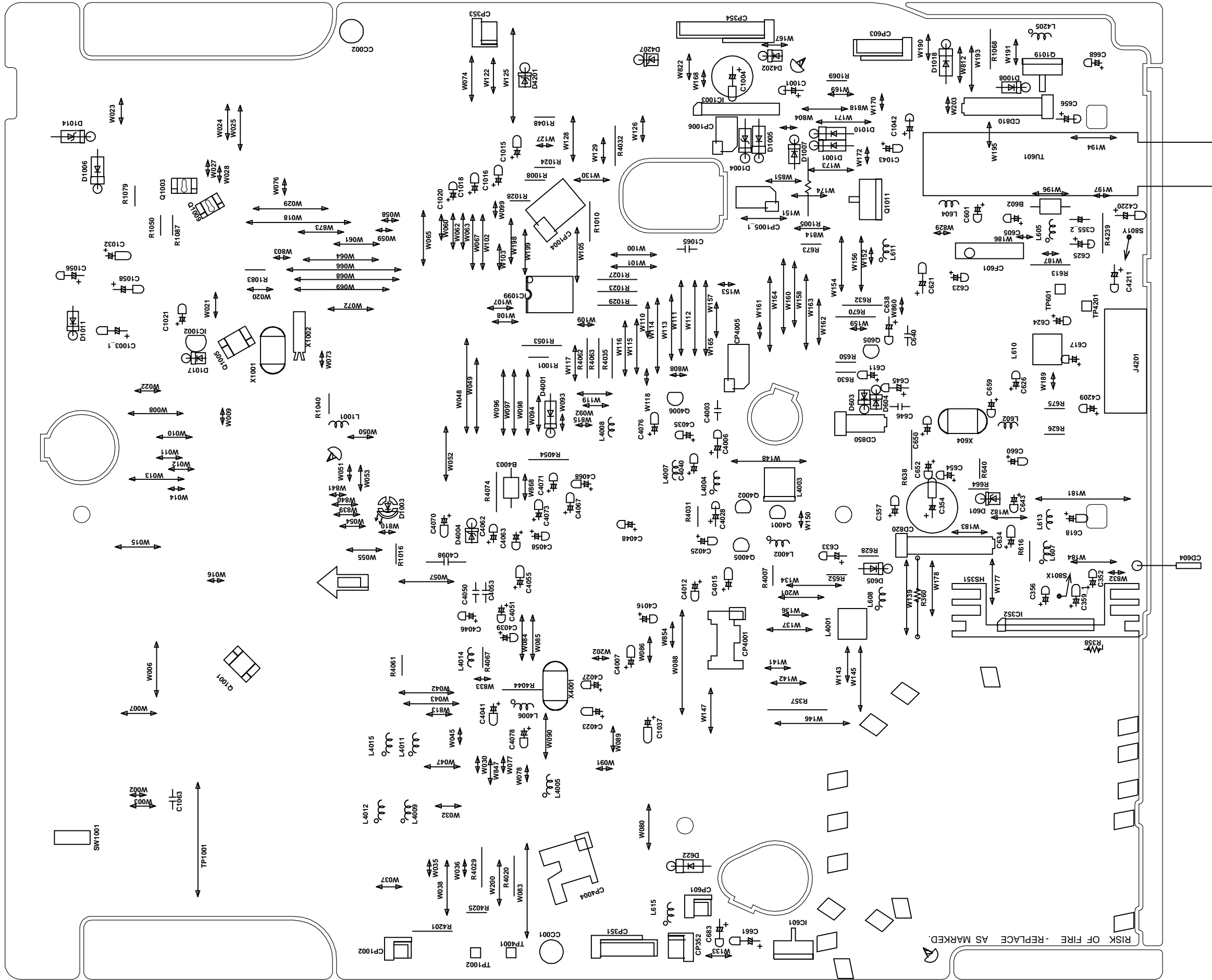

PRINTED CIRCUIT BOARDS SYSCON

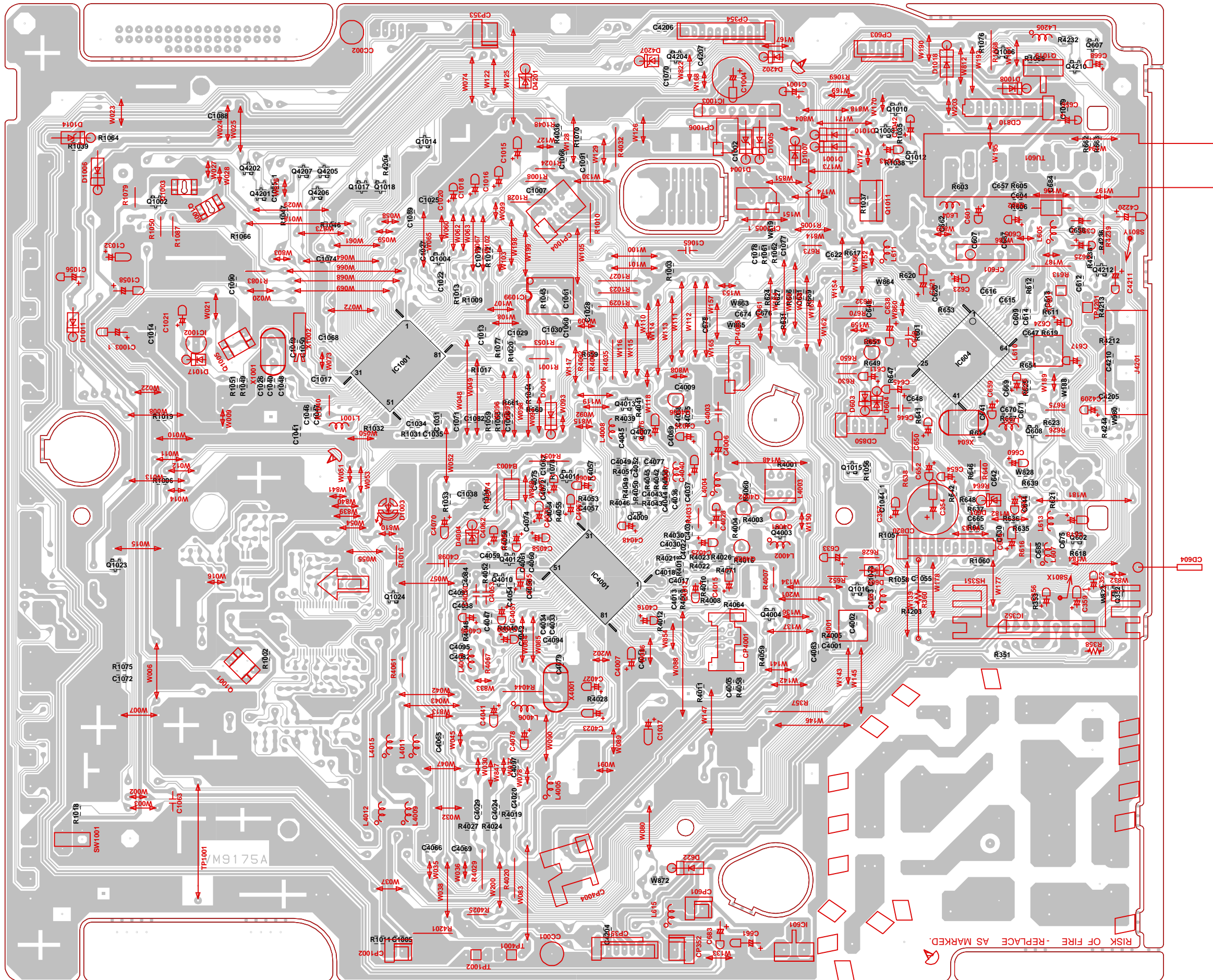

Y/C/AUDIO/HEAD AMP SCHEMATIC DIAGRAM (SYSCON PCB)

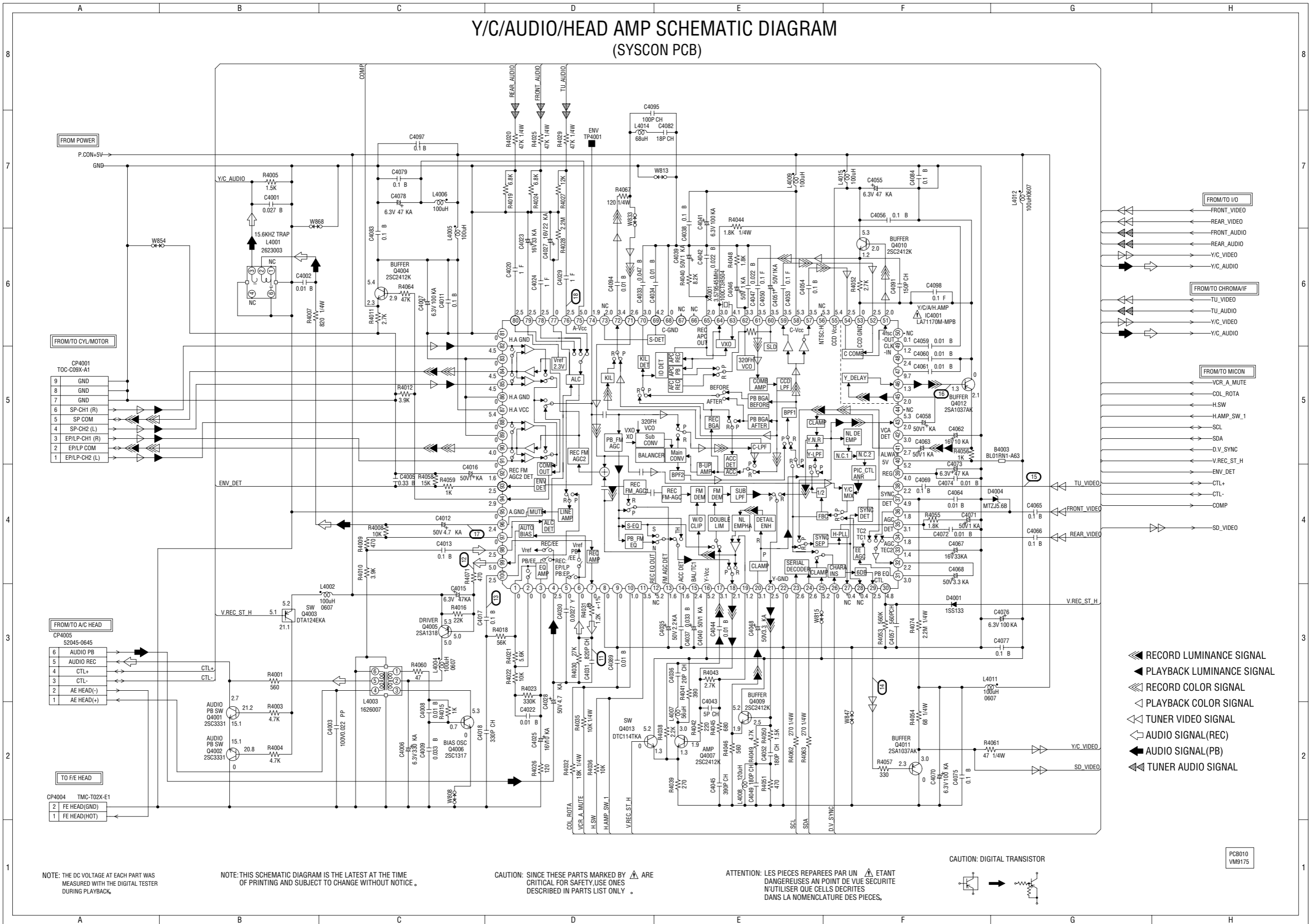

MICON SCHEMATIC DIAGRAM (SYSCON PCB)

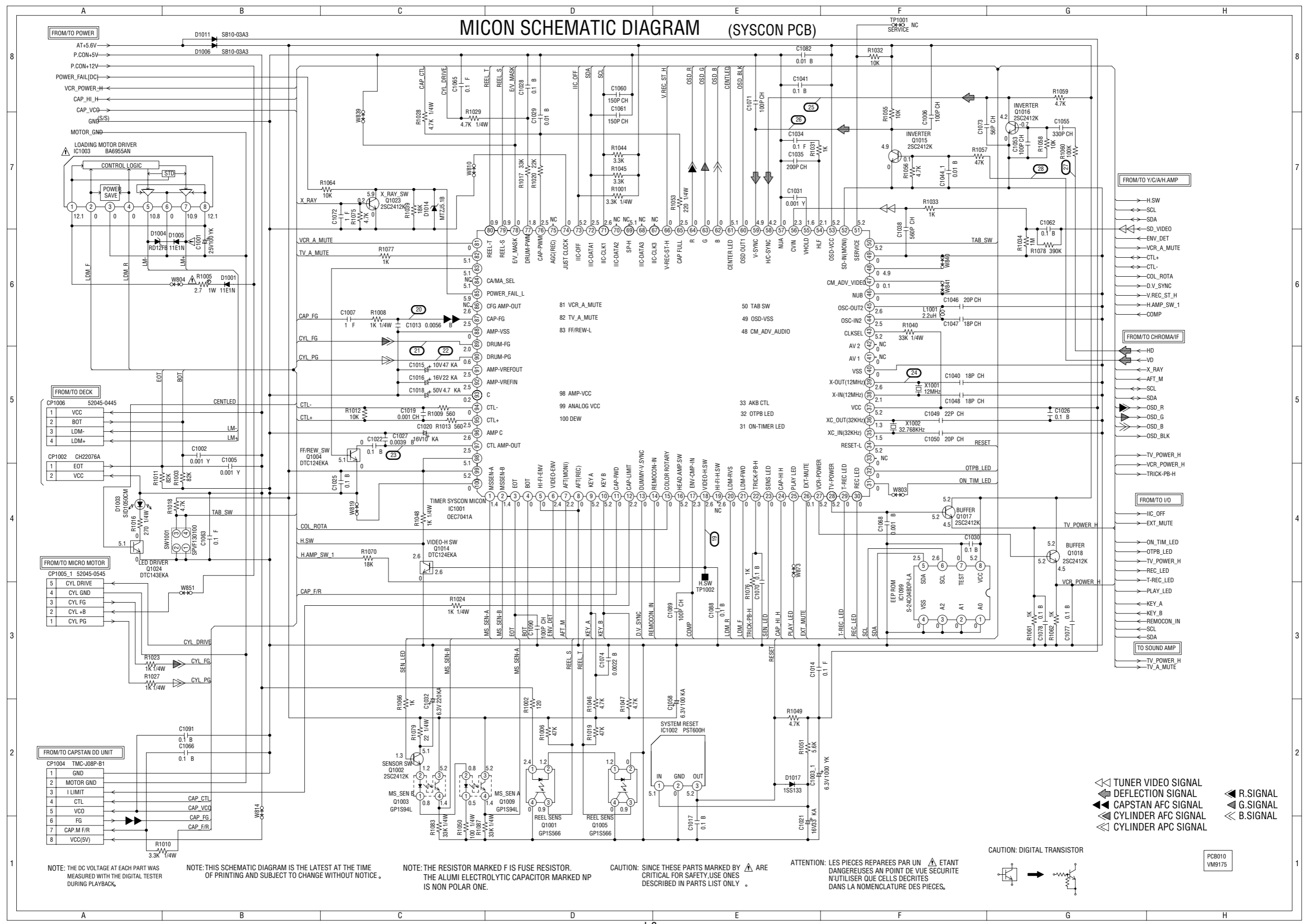

NOTE: THE DC VOLTAGE AT EACH PART WAS MEASURED WITH THE DIGITAL TESTER DURING PLAYBACK.

NOTE: THIS SCHEMATIC DIAGRAM IS THE LATEST AT THE TIME OF PRINTING AND SUBJECT TO CHANGE WITHOUT NOTICE.

NOTE: THE RESISTOR MARKED F IS FUSE RESISTOR. THE ALUMI ELECTROLYTIC CAPACITOR MARKED NP IS NON POLAR ONE.

CAUTION: SINCE THESE PARTS MARKED BY ARE CRITICAL FOR SAFETY, USE ONES DESCRIBED IN PARTS LIST ONLY.

ATTENTION: LES PIECES REPARÉES PAR UN ÉTANT DANGEREUSES AN POINT DE VUE SECURITE N'UTILISER QUE CELLS DECRITES DANS LA NOMENCLATURE DES PIECES.

CAUTION: DIGITAL TRANSISTOR

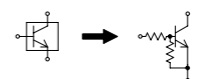

- TUNER VIDEO SIGNAL
- DEFLECTION SIGNAL
- CAPSTAN AFC SIGNAL
- CYLINDER AFC SIGNAL
- CYLINDER APC SIGNAL
- R.SIGNAL
- G.SIGNAL
- B.SIGNAL

PCB010 VM9175

IN/OUT SCHEMATIC DIAGRAM (SYSCON PCB)

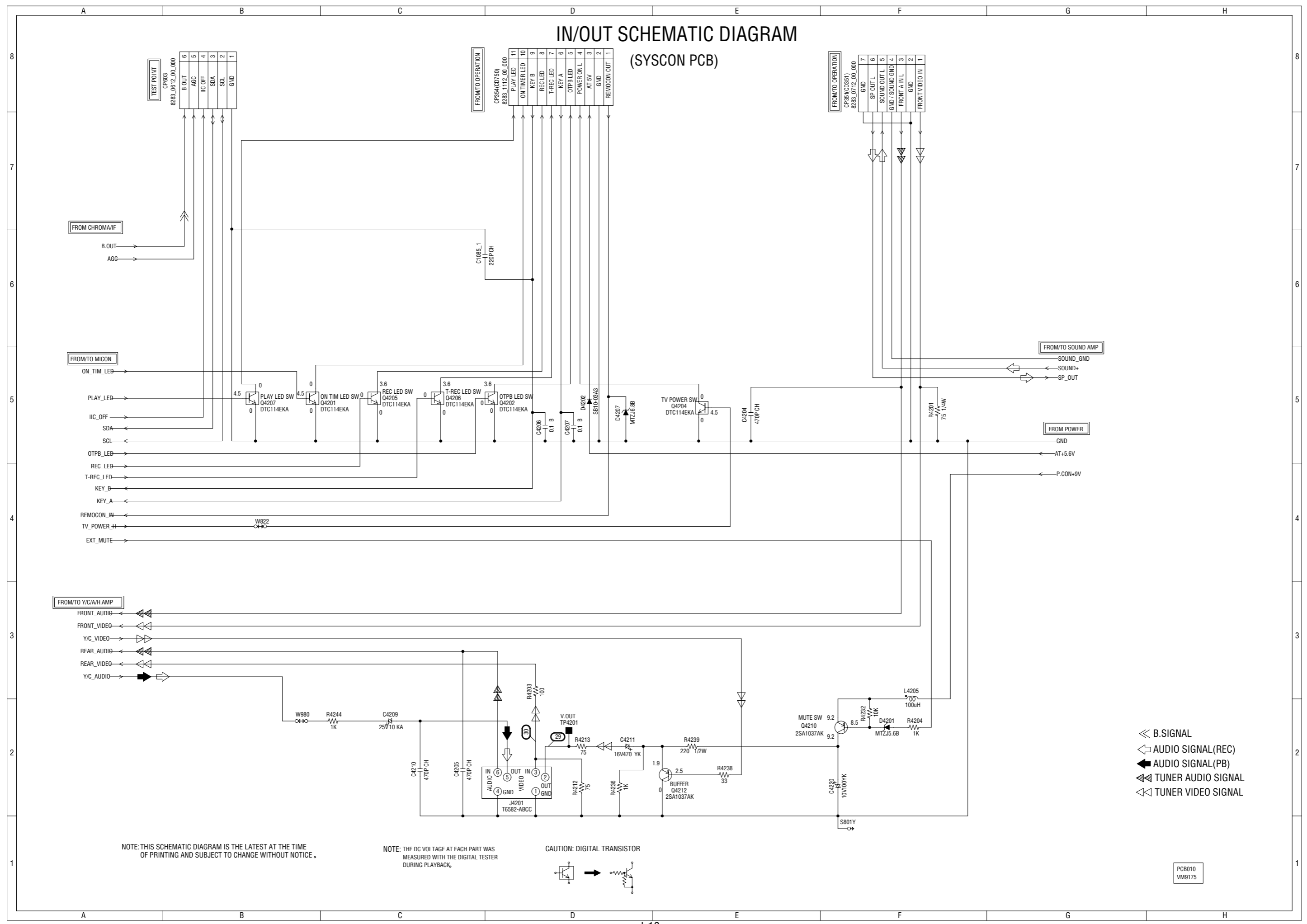

NOTE: THIS SCHEMATIC DIAGRAM IS THE LATEST AT THE TIME OF PRINTING AND SUBJECT TO CHANGE WITHOUT NOTICE.

NOTE: THE DC VOLTAGE AT EACH PART WAS MEASURED WITH THE DIGITAL TESTER DURING PLAYBACK.

CAUTION: DIGITAL TRANSISTOR

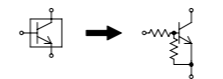

- ◁ B.SIGNAL
- ⇐ AUDIO SIGNAL (REC)
- ➡ AUDIO SIGNAL (PB)
- ▶ TUNER AUDIO SIGNAL
- ▷ TUNER VIDEO SIGNAL

PC8010
VM9175

POWER SCHEMATIC DIAGRAM (SYSCON PCB)

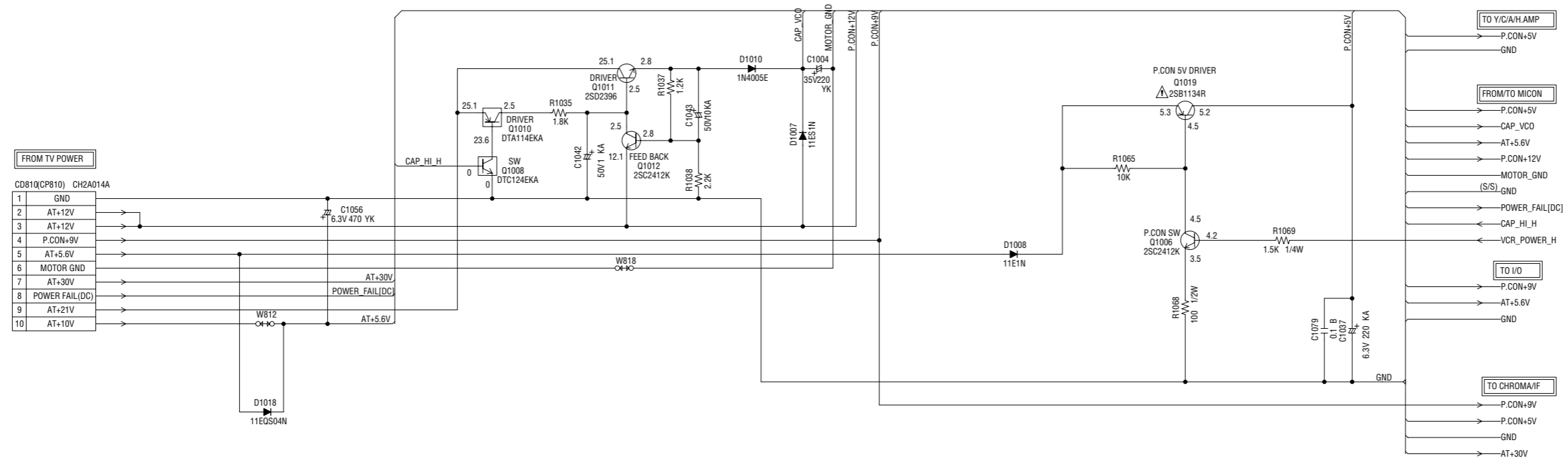

NOTE: THE DC VOLTAGE AT EACH PART WAS MEASURED WITH THE DIGITAL TESTER DURING PLAYBACK.

NOTE: THIS SCHEMATIC DIAGRAM IS THE LATEST AT THE TIME OF PRINTING AND SUBJECT TO CHANGE WITHOUT NOTICE.

CAUTION: SINCE THESE PARTS MARKED BY ARE CRITICAL FOR SAFETY, USE ONES DESCRIBED IN PARTS LIST ONLY.

ATTENTION: LES PIECES REPAREES PAR UN ETANT DANGEREUSES AN POINT DE VUE SECURITE N'UTILISER QUE CELLS DECRITES DANS LA NOMENCLATURE DES PIECES.

CAUTION: DIGITAL TRANSISTOR

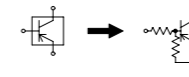

CAUTION: DIGITAL TRANSISTOR

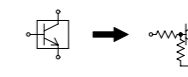

PCB010
VM9175

SOUND AMP SCHEMATIC DIAGRAM (SYSCON PCB)

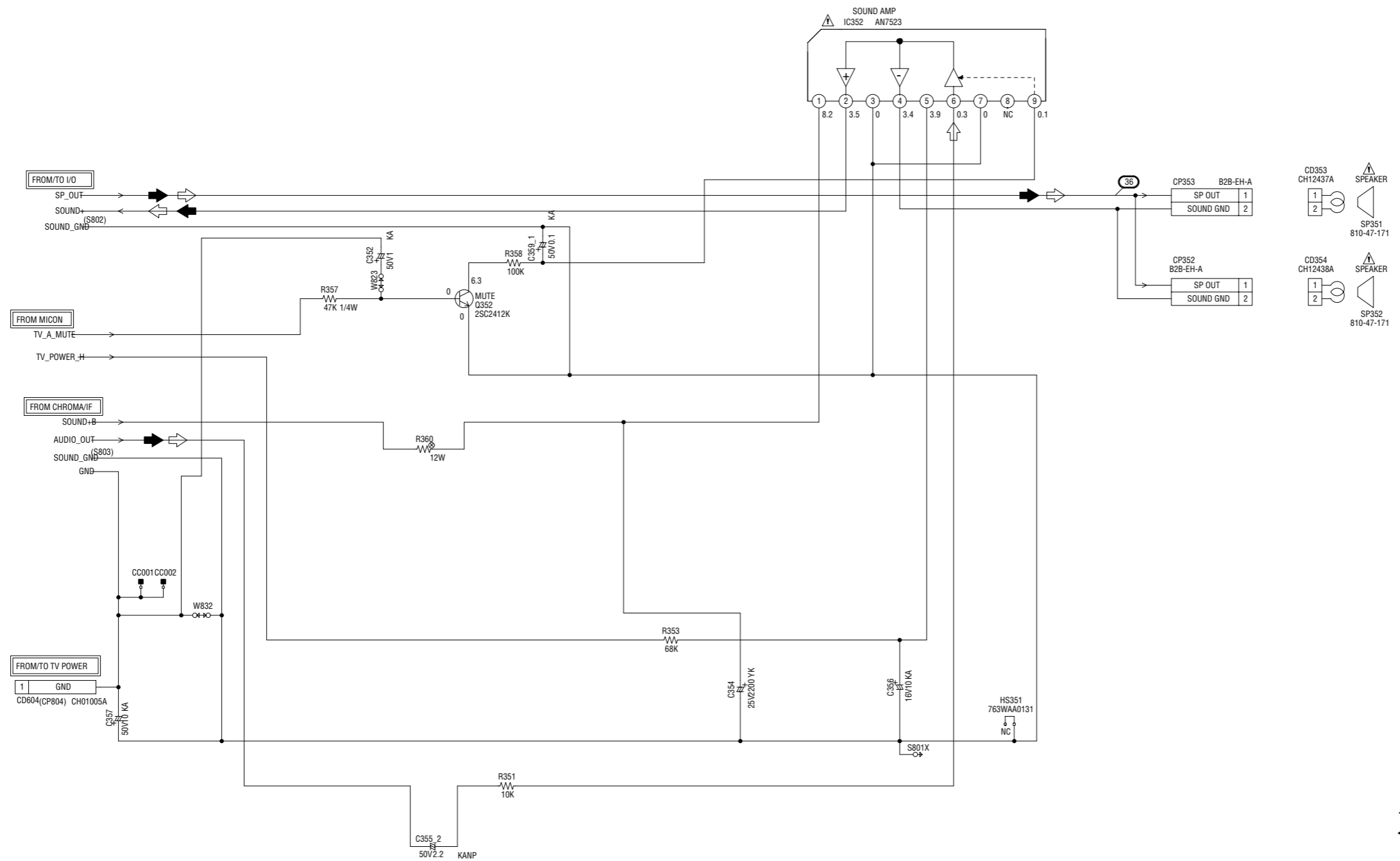

AUDIO SIGNAL (REC)
 AUDIO SIGNAL (PB)

NOTE: THIS SCHEMATIC DIAGRAM IS THE LATEST AT THE TIME OF PRINTING AND SUBJECT TO CHANGE WITHOUT NOTICE.

NOTE: THE DC VOLTAGE AT EACH PART WAS MEASURED WITH THE DIGITAL TESTER WHEN THE COLOR BROADCAST WAS RECEIVED IN GOOD CONDITION AND PICTURE IS NORMAL.

CAUTION: SINCE THESE PARTS MARKED BY ARE CRITICAL FOR SAFETY, USE ONES DESCRIBED IN PARTS LIST ONLY.

ATTENTION: LES PIÈCES RÉPARÉES PAR UN ÉTANT DANGEREUSES AU POINT DE VUE SÉCURITÉ N'UTILISER QUE CELLES DÉCRITES DANS LA NOMENCLATURE DES PIÈCES.

PCB010
VM9175

DEFLECTION SCHEMATIC DIAGRAM (MAIN PCB)

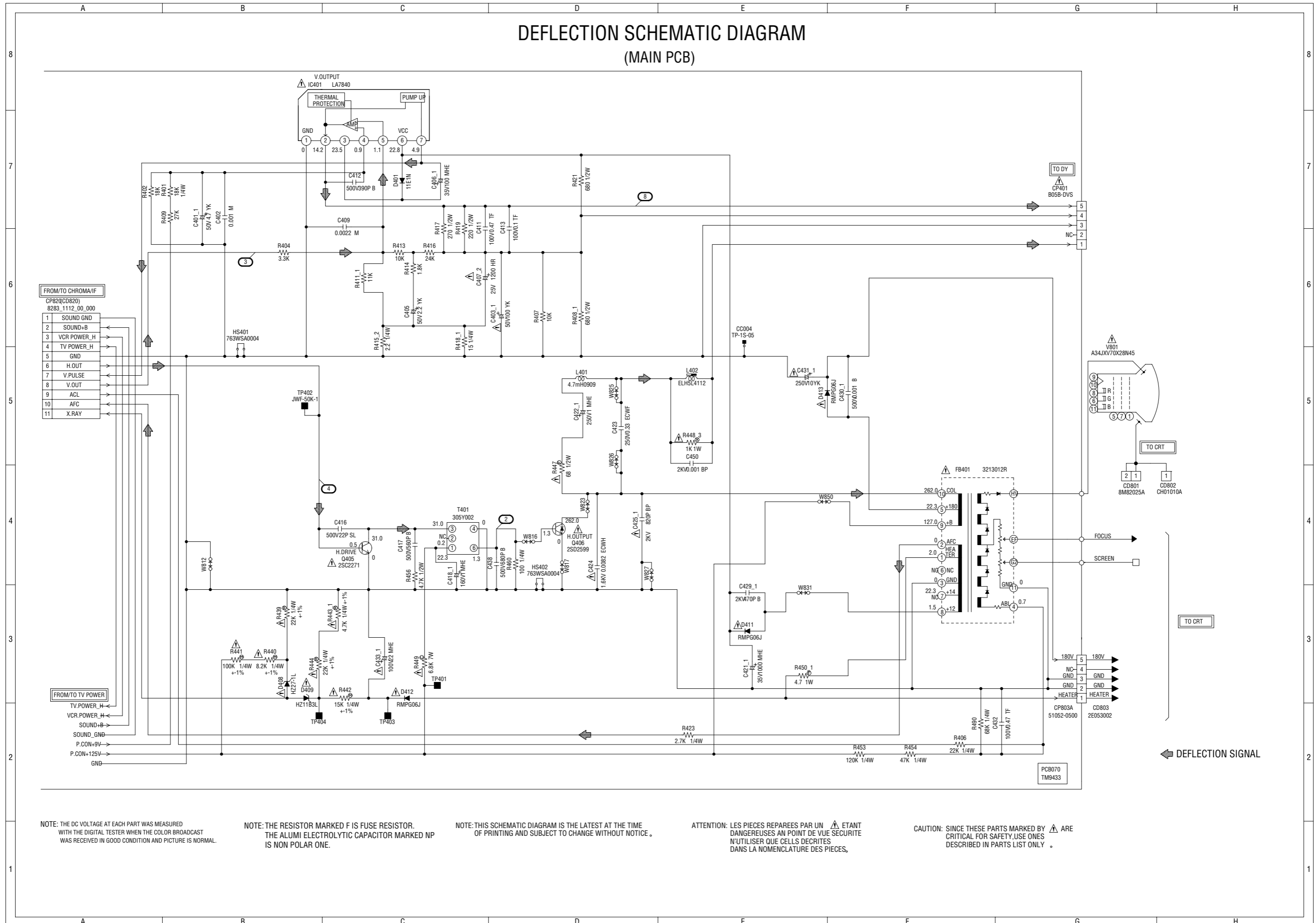

FROM/TO CHROMA/IF
CP82Q(CD82Q)
8283_1112_00_000

1	SOUND_GND
2	SOUND+B
3	VCR_POWER_H
4	TV_POWER_H
5	GND
6	H.OUT
7	V.PULSE
8	V.OUT
9	ACL
10	AFC
11	X.RAY

FROM/TO TV POWER

TV_POWER_H
VCR_POWER_H
SOUND+B
SOUND_GND
P.CON+9V
P.CON+125V
GND

NOTE: THE DC VOLTAGE AT EACH PART WAS MEASURED WITH THE DIGITAL TESTER WHEN THE COLOR BROADCAST WAS RECEIVED IN GOOD CONDITION AND PICTURE IS NORMAL.

NOTE: THE RESISTOR MARKED F IS FUSE RESISTOR. THE ALUMI ELECTROLYTIC CAPACITOR MARKED NP IS NON POLAR ONE.

NOTE: THIS SCHEMATIC DIAGRAM IS THE LATEST AT THE TIME OF PRINTING AND SUBJECT TO CHANGE WITHOUT NOTICE.

ATTENTION: LES PIECES REPARÉES PAR UN Δ ETANT DANGEREUSES AN POINT DE VUE SECURITE N'UTILISER QUE CELLS DECRITES DANS LA NOMENCLATURE DES PIECES.

CAUTION: SINCE THESE PARTS MARKED BY Δ ARE CRITICAL FOR SAFETY, USE ONES DESCRIBED IN PARTS LIST ONLY.

CRT SCHEMATIC DIAGRAM (CRT PCB)

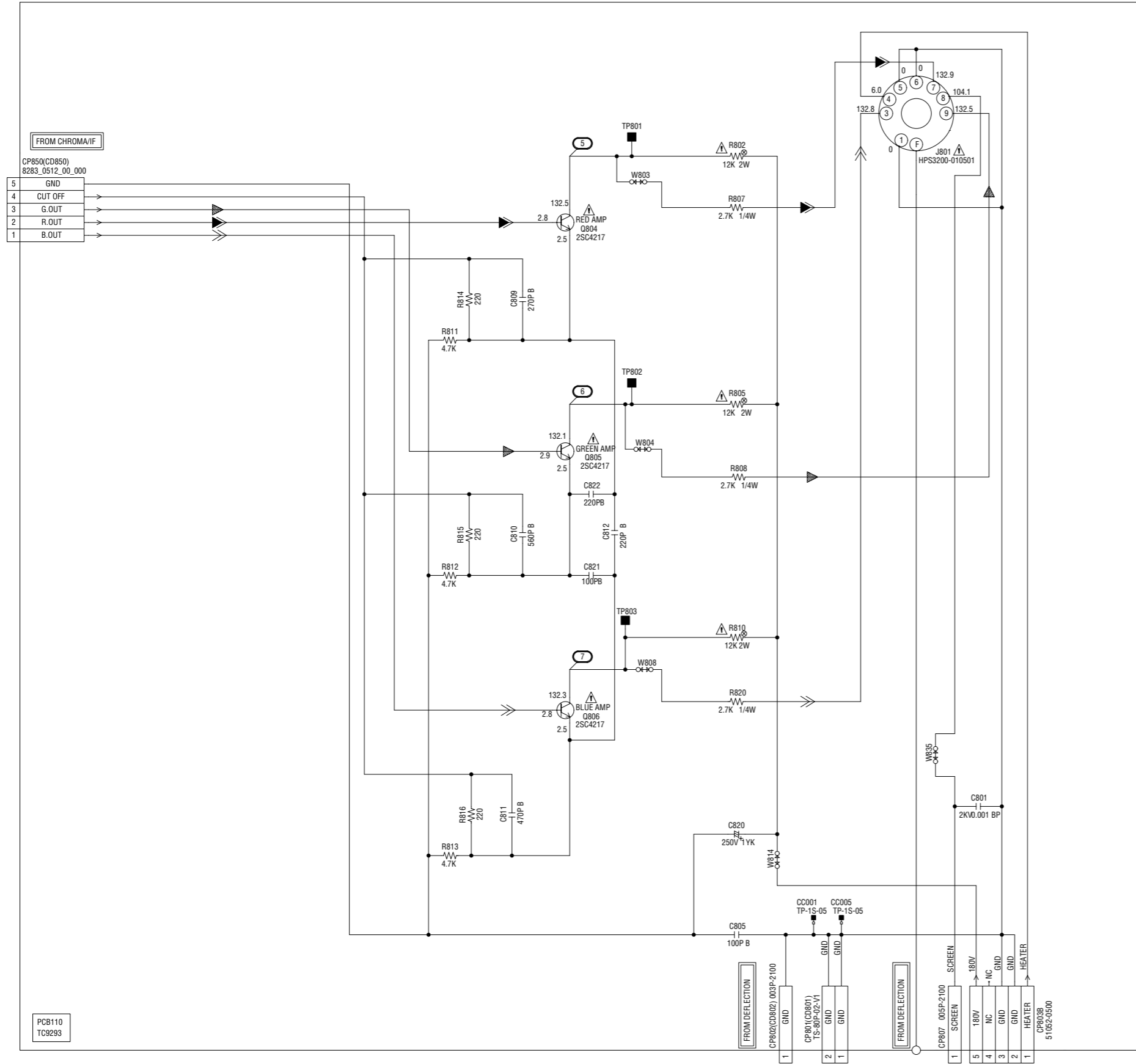

FROM CHROMA/IF	
5	GND
4	CUT OFF
3	G.OUT
2	R.OUT
1	B.OUT

PCB110
TC9293

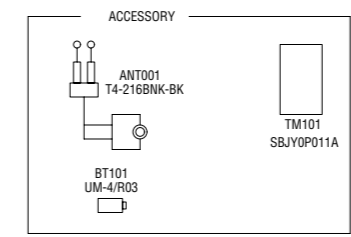

- ◀ R.SIGNAL
- ◀ G.SIGNAL
- ◀ B.SIGNAL

CAUTION: SINCE THESE PARTS MARKED BY ARE CRITICAL FOR SAFETY, USE ONES DESCRIBED IN PARTS LIST ONLY.

ATTENTION: LES PIÉCES REPARÉES PAR UN ÉTANT DANGEREUSES AN POINT DE VUE SECURITE N'UTILISER QUE CELLES DÉCRITES DANS LA NOMENCLATURE DES PIÉCES.

NOTE: THIS SCHEMATIC DIAGRAM IS THE LATEST AT THE TIME OF PRINTING AND SUBJECT TO CHANGE WITHOUT NOTICE.

NOTE: THE DC VOLTAGE AT EACH PART WAS MEASURED WITH THE DIGITAL TESTER WHEN THE COLOR BROADCAST WAS RECEIVED IN GOOD CONDITION AND PICTURE IS NORMAL.

INTERCONNECTION DIAGRAM

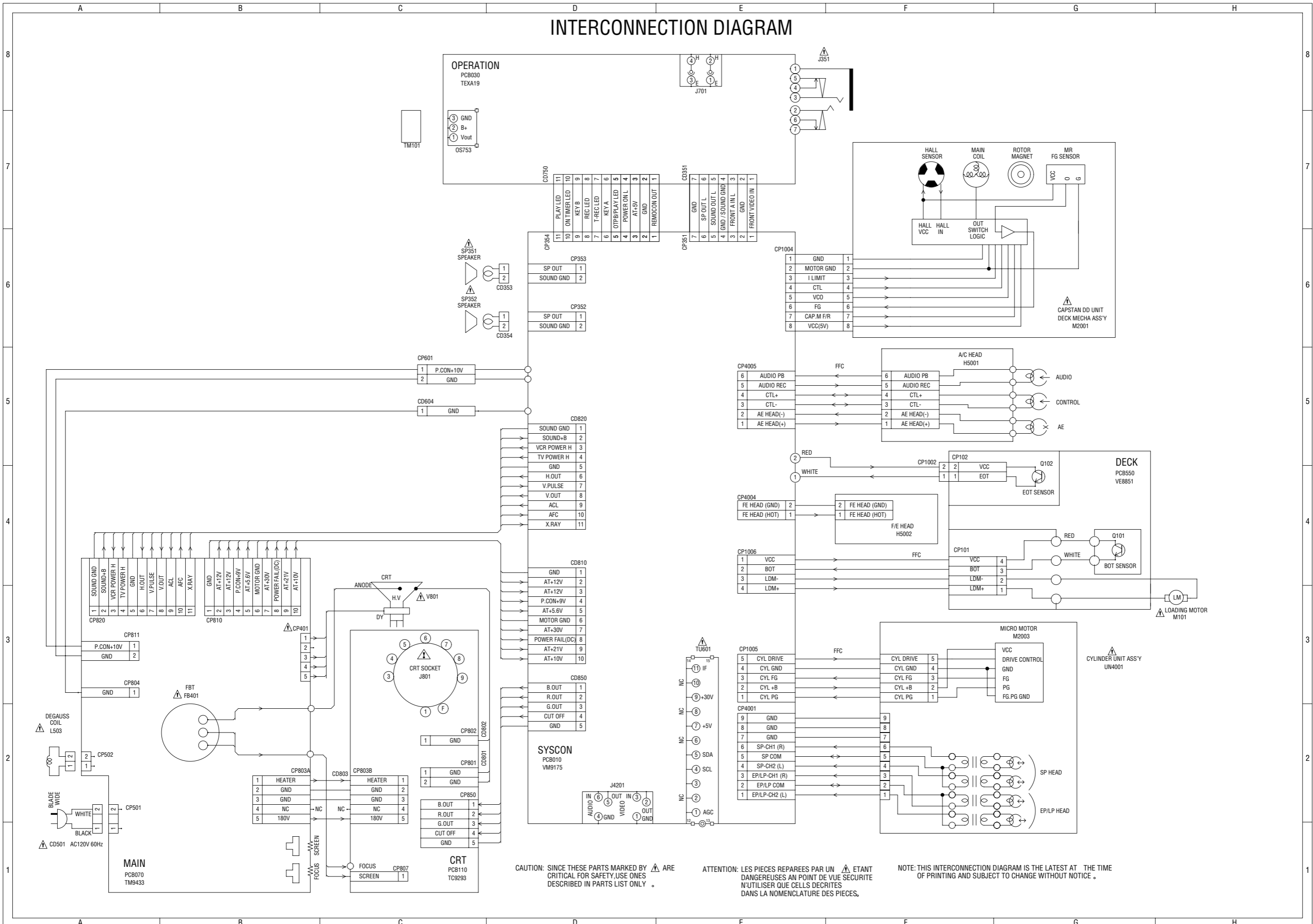

CAUTION: SINCE THESE PARTS MARKED BY ⚠ ARE CRITICAL FOR SAFETY, USE ONES DESCRIBED IN PARTS LIST ONLY.

ATTENTION: LES PIÈCES RÉPARÉES PAR UN ⚠ ÉTANT DANGEREUSES AN POINT DE VUE SECURITE N'UTILISER QUE CELLS DECRITES DANS LA NOMENCLATURE DES PIÈCES.

NOTE: THIS INTERCONNECTION DIAGRAM IS THE LATEST AT THE TIME OF PRINTING AND SUBJECT TO CHANGE WITHOUT NOTICE.

WAVEFORMS

TV POWER

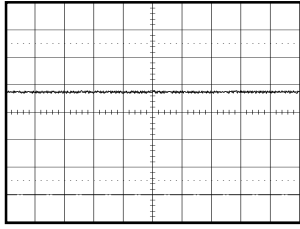

① 5.0V 0.1ms/div

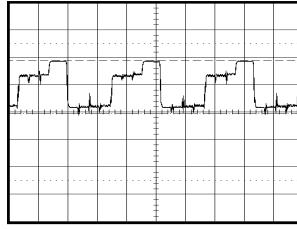

⑥ 50.0V 20μs/div

Y/C/AUDIO/HEAD AMP

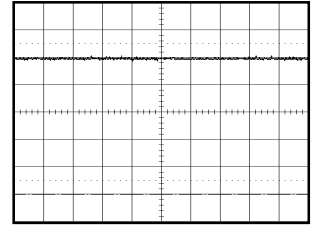

⑪ PB
0.5V 0.5ms/div

DEFLECTION

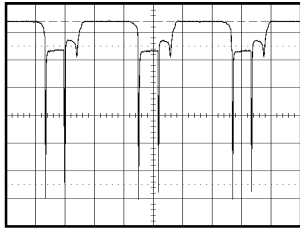

② 2.0V 20μs/div

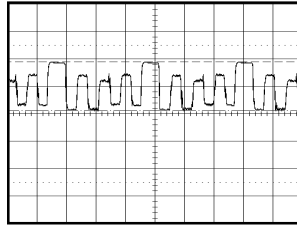

⑦ 50.0V 20μs/div

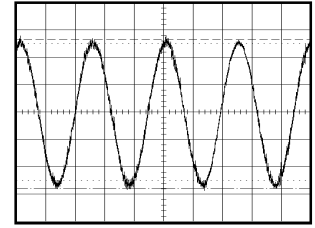

⑫ PB
100mV 1ms/div

DEFLECTION

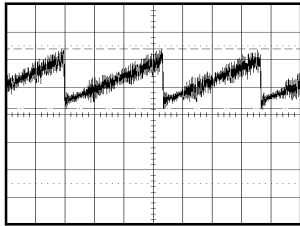

③ 0.5V 5ms/div

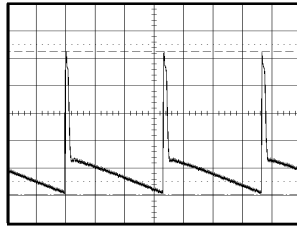

⑧ 10.0V 5ms/div

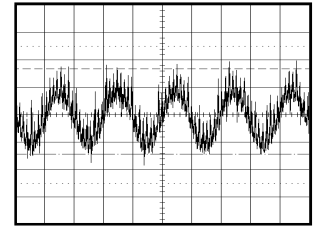

⑬ PB
50mV 0.5ms/div

TV POWER

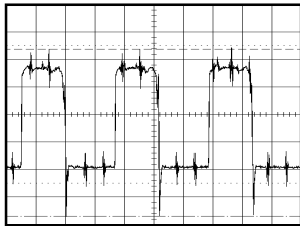

④ 200mV 20μs/div

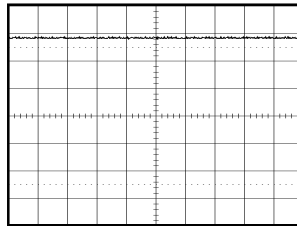

⑨ 20.0V 0.1ms/div

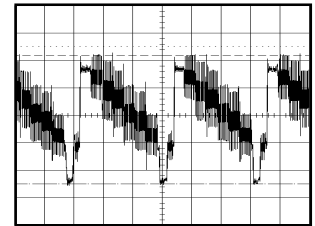

⑭ PB
0.5V 20μs/div

CRT

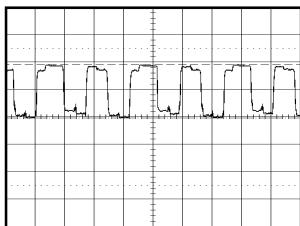

⑤ 50.0V 20μs/div

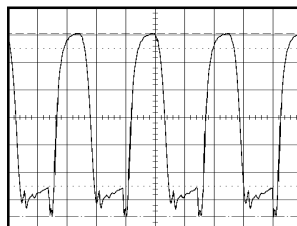

⑩ 0.5V 5μs/div

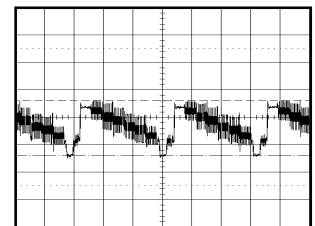

⑮ POWER ON
0.5V 20μs/div

NOTE: The following waveforms were measured at the point of the corresponding balloon number in the schematic diagram.

WAVEFORMS

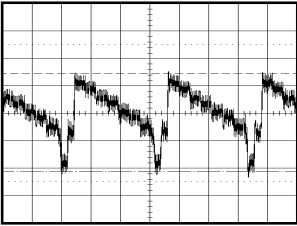

①⑥ REC
100mV 20 μ s/div

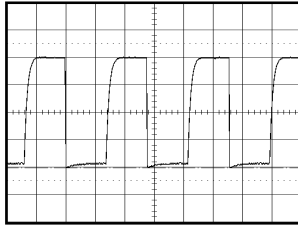

②① PB
1.0V 0.5ms/div

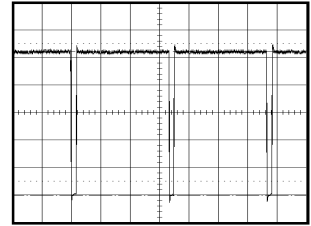

②⑥ POWER ON
0.5V 10ms/div

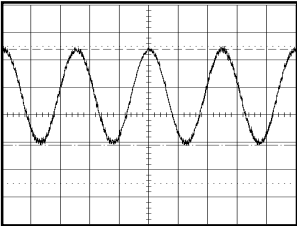

①⑦ POWER ON
0.5V 1ms/div

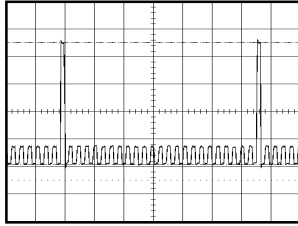

②② PB
1.0V 5ms/div

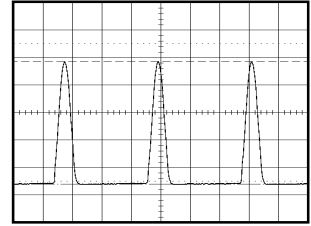

②⑦ POWER ON
20.0V 20 μ s/div

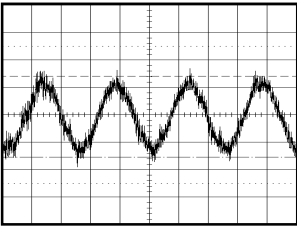

①⑧ POWER ON
50mV 1ms/div

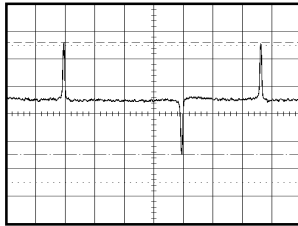

②③ PB
1.0V 5ms/div

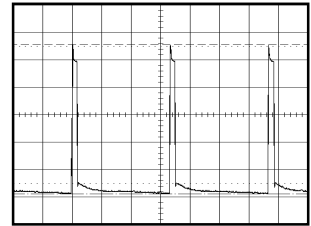

②⑧ POWER ON
5.0V 5ms/div

MICON

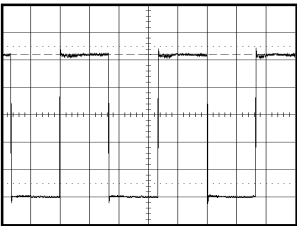

①⑨ PB
1.0V 10ms/div

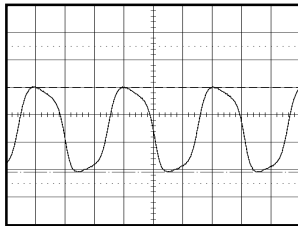

②④ POWER ON
1.0V 10 μ s/div

IN/OUT

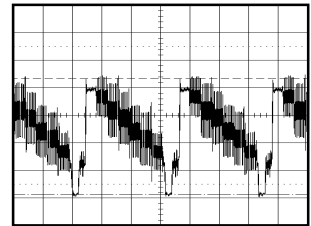

②⑨ POWER ON
0.5V 20 μ s/div

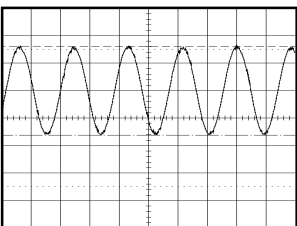

②⑩ PB
0.5V 0.5ms/div

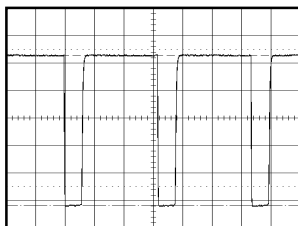

②⑤ POWER ON
1.0V 20 μ s/div

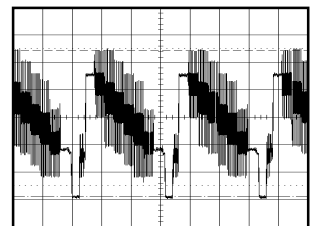

③⑩ POWER ON
200mV 20 μ s/div

NOTE: The following waveforms were measured at the point of the corresponding balloon number in the schematic diagram.

WAVEFORMS

CHROMA/IF

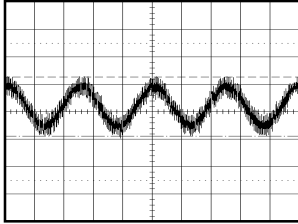

③① POWER ON
0.5V 1ms/div

SOUND AMP

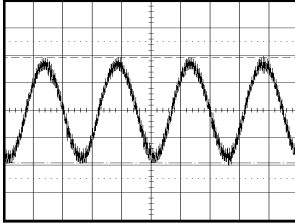

③⑥ POWER ON
200mV 1ms/div

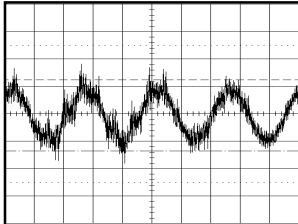

③② POWER ON
50mV 1ms/div

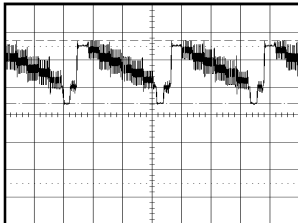

③③ POWER ON
0.5V 20μs/div

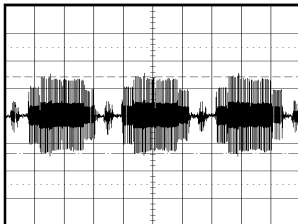

③④ POWER ON
200mV 20μs/div

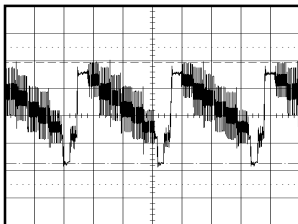

③⑤ POWER ON
10.5V 20μs/div

NOTE: The following waveforms were measured at the point of the corresponding balloon number in the schematic diagram.

MECHANICAL EXPLODED VIEW

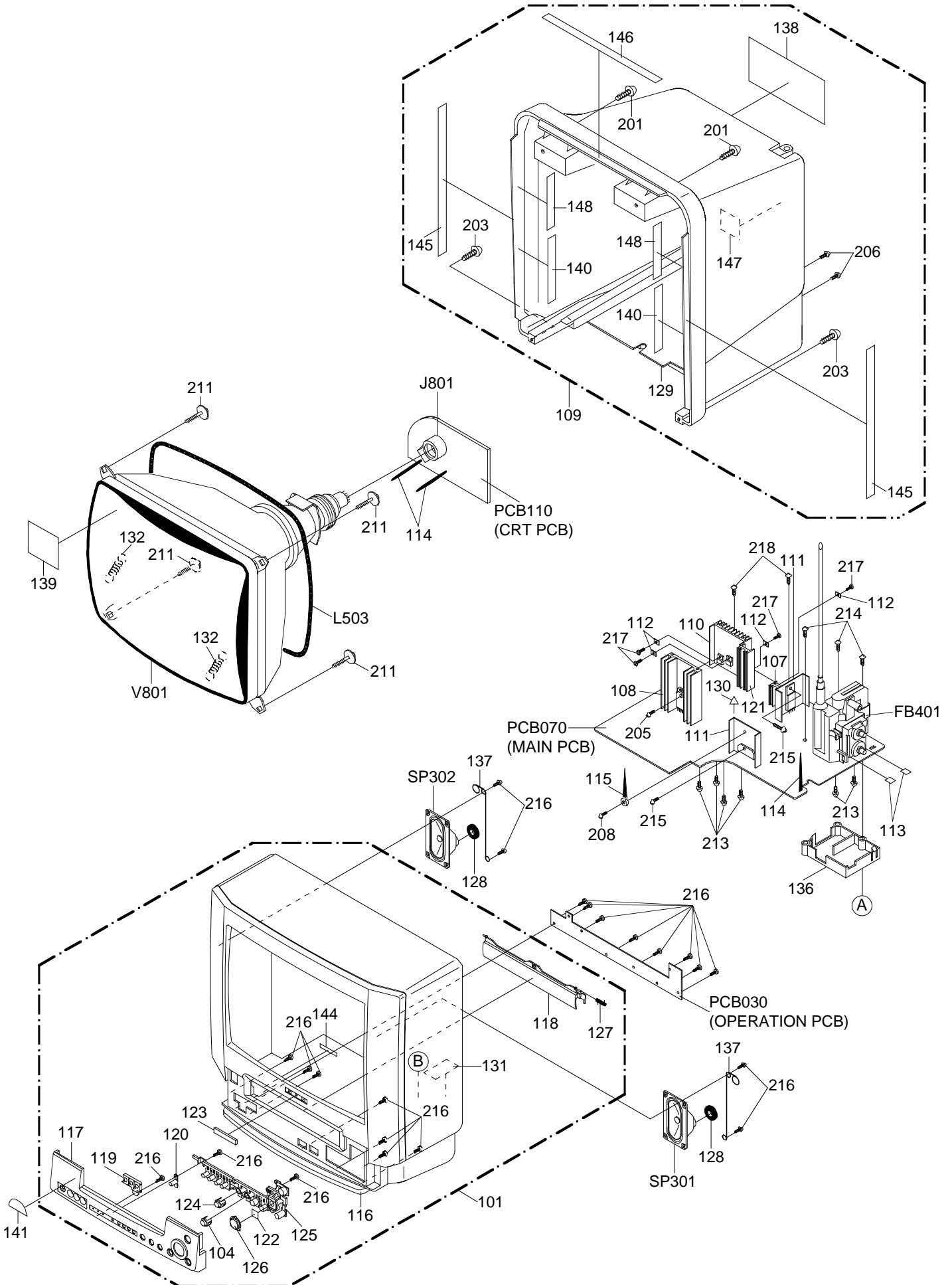

MECHANICAL EXPLODED VIEW

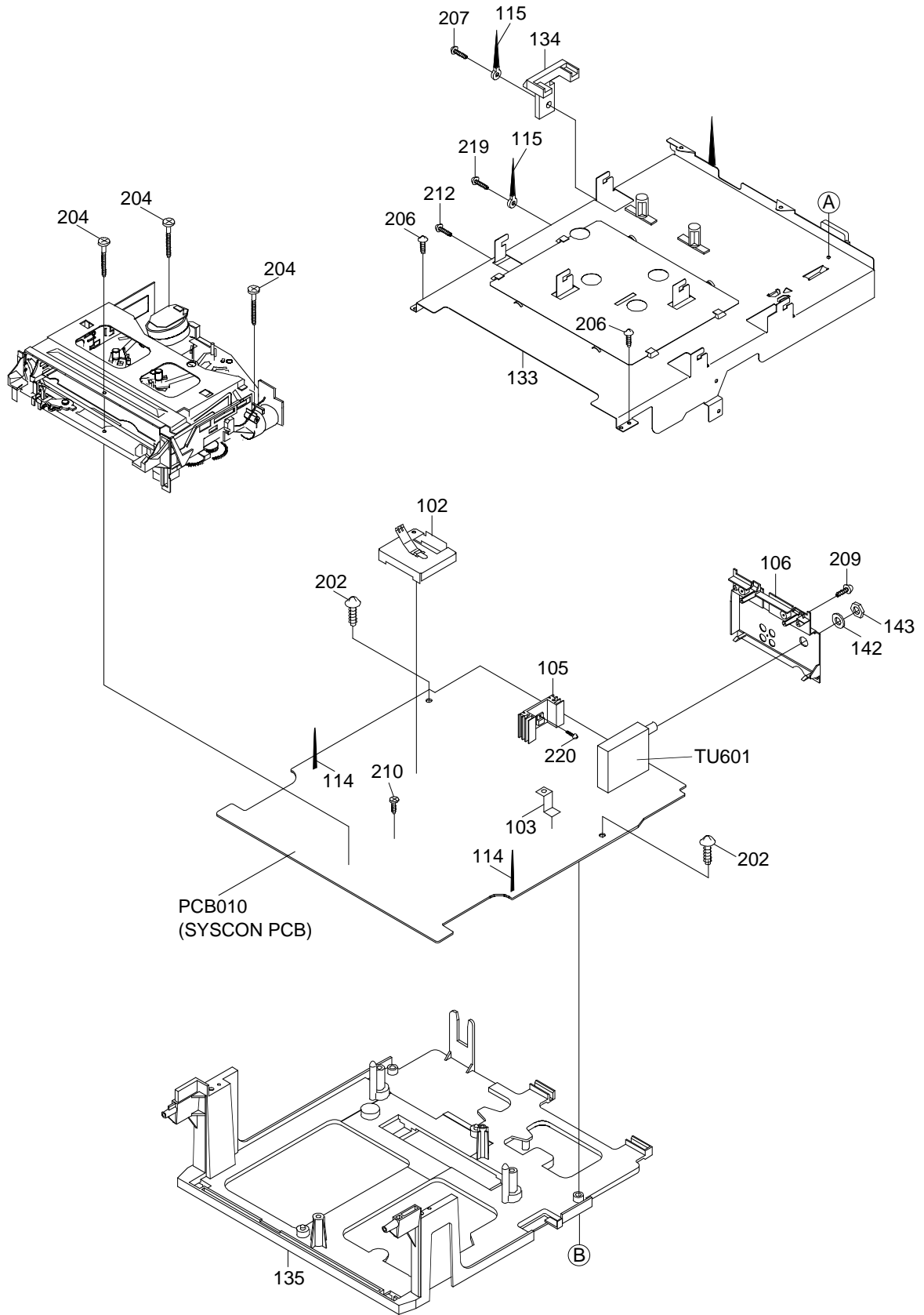

MECHANICAL REPLACEMENT PARTS LIST

REF. NO.	PART NO.	DESCRIPTION	Q'TY	REF. NO.	PART NO.	DESCRIPTION	Q'TY
101	S5-505-1C7-200	CABINET,FRONT ASS'Y	1	140	----	FELT SHEET	2
102	----	SHIELD,CASE HEAD AMP ASS'Y	1	141	----	LABEL,ENEKY STAR	1
103	----	PLATE,EARTH-SYSCON	1	142	S2-A97-A40-770	WASHER 9.7x14xT0.7	1
104	S3-5WP-D06-800	BUTTON,REC	1	143	S3-004-952-070	NUT 3/8 INCH	1
105	----	HEAT SINK	1	144	----	FELT SHEET	1
106	S7-1WP-AA0-100	PLATE,JACK	1	145	----	FELT SHEET	2
107	----	HEAT SINK	1	146	----	FELT SHEET	1
108	----	HEAT SINK	1	147	----	FELT SHEET	1
109	S5-505-1C7-400	CABINET,BACK ASS'Y	1	148	----	FELT SHEET	2
110	----	HEAT SINK	1	201	S1-172-40C-540	SCREW,TAP(B0)BIND 4-35	2
111	----	HEAT SINK	2	202	S1-175-40B-040	SCREW,TAP(B0)TRUSS 4-20	2
112	----	METAL SPACER	4	203	S1-175-40A-640	TAP(B0)4-16	2
113	----	RUBBER,SILCON	2	204	S1-171-40A-240	TAP(B0)V+4-12	3
114	----	COATING CLIP	5	205	S1-0A1-30A-040	SCREW,WASHER(B)M3-10	1
115	----	CORD CLIP UL CO.	3	206	S1-106-30A-240	SCREW,TAP(P)3-12	4
116	----	CABINET,FRONT	1	207	S1-072-308-040	UT2+3-8	1
117	S1-2WP-J06-800	PLATE,FRONT	1	208	S1-0A1-308-040	SCREW,M3x8	1
118	S1-2WP-J06-810	FLAP	1	209	S1-102-30A-020	VT2+3-10	1
119	S1-3WP-A01-110	GLASS,LED	1				
120	S1-3WP-A01-100	GUIDE,REMOCON	1	210	87-741-095-410	SCREW,TAP TITE(P) FLAT 3-8	1
121	----	HEAT SINK	1	211	S1-21F-50B-840	SCREW,TAP 5-28	4
122	----	SHEET,LED	1	212	87-743-073-010	VT2+2.6-6	1
123	S2-344-901-020	BADGE,BRAND	1	213	87-753-095-410	SCREW,TAP 3-8	6
124	S3-5WP-D06-790	BUTTON,OTPB	1	214	S1-0A1-30B-040	SCREW,WASHER(A) M3x20	3
125	S3-5WP-J01-280	BUTTON,FRAME	1	215	S1-0B1-308-040	SCREW/WASHER(B)M3-8	2
126	S3-5WP-D06-860	BUTTON,PLAY	1	216	S1-106-30A-040	UIT+3-10	22
127	S4-3WK-A00-320	SPR,FLAP	1	217	S1-0A1-30A-040	SCREW,WASHER(A) M3x10	4
128	----	RUBBER,SPEAKER	2	218	S1-0A1-306-040	SCREW,WASHER(A)M3-6	2
129	----	CABI,BACK	1	219	S1-076-306-040	BVTT+3-6	1
				220	S1-106-306-040	SCREW,TAP 3-6	1
130	----	SHEET,FUSE	1				
131	----	SHEET,CRT SERVICEMAN	1				
132	----	SPRING,EARTH	2				
133	----	PLATE,DECK SHIELD ASS'Y	1				
134	S6-1WP-A01-510	HOLDER,M/PCB	1				
135	S6-1WP-A01-570	HOLDER,DECK	1				
136	S6-1WP-A01-450	HOLDER,FBT	1				
137	----	WIRE,SPEAKER	2				
138	----	SHEET,RATING	1				
139	----	LABEL,POP	1				

ACCESSORY REPLACEMENT PARTS LIST

REF. NO.	PART NO.	DESCRIPTION	Q'TY
1	S2-5C1-080-270	ANTENNA,ROD	1
2	S7-660-DB0-200	TRANSMITTER(VXC131)	1
3	S5-505-101-000	INSTRUCTION BOOK	1

CHASSIS EXPLODED VIEW (BOTTOM VIEW)

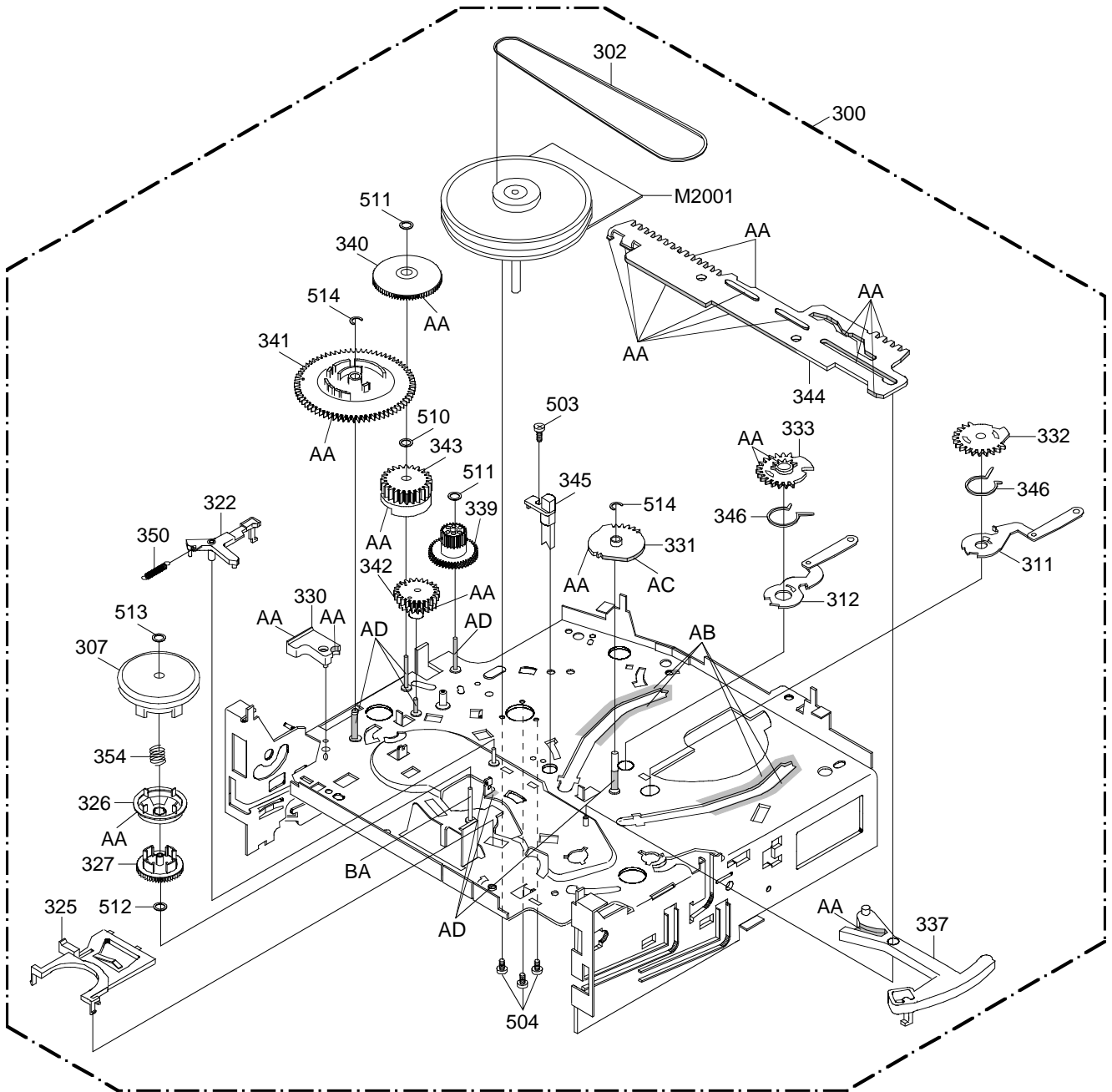

CLASS	PART NO.	MARK
GREASE	G-555G	AA
	G-488M	AB
	FL-721	AC
	MG-33	AD
OIL	KYODO OIL SLIDAS No. 150	BA

NOTE: Applying positions AA, AB, AC, AD and BA for the grease or oil are displayed for this section. Check if the correct grease or oil is applied for each position.

CHASSIS REPLACEMENT PARTS LIST

REF. NO.	PART NO.	DESCRIPTION	Q'TY	REF. NO.	PART NO.	DESCRIPTION	Q'TY
300	----	DECK ASS'Y A55002A420A	1	360	S5-OP9-006-860	TAPE GUIDE R	1
301	S5-OA5-000-220	AHC ASS'Y	1	361	S5-OP9-007-070	COVER,SENSOR L	1
302	S5-OP2-002-700	BELT,CAPSTAN	1	362	S5-OP9-006-880	LEVER,FLAP	1
303	S5-OP9-007-100	LEVER,REC	1	363	S5-OP9-006-900	CASS HOLDER	1
304	S5-OP5-000-830	BASE,AC HEAD	1	364	S5-OP9-006-910	LOCKER,L	1
305	S5-OP8-003-240	SPR,AC HEAD	1	365	S5-OP9-006-920	LOCKER,R	1
306	S5-OA0-003-600	MAIN CHASSIS ASS'Y	1	366	S5-OP9-006-940	SPR,PACK	2
307	S5-OA2-000-810	CLUTCH ASS'Y X	1	367	S5-OP9-006-950	BRACKET,TOP	1
308	S5-OA2-000-730	ARM,IDLER ASS'Y	1	368	----	SPR,CASS EARTH	1
309	S5-OP6-005-530	ARM,S-S BRAKE	1	369	S5-OP6-005-400	DRIVER,WORM	1
310	S5-OA2-000-760	T REEL ASS'Y	1	370	S5-OP6-005-630	BRACKET,MOTOR	1
311	S5-OA3-000-610	LOAD ARM S ASS'Y	1	371	S5-OP6-005-410	WORM	1
312	S5-OA3-000-620	LOAD ARM T ASS'Y	1	501	87-654-075-410	SCREW,TAP 2.6-10	1
313	S5-OA4-001-870	G-ROLLER ASS'Y	2	502	S1-072-268-040	VT2+2.6-8	3
314	S5-OA4-001-880	BASE,INCL S ASS'Y	1	503	87-743-073-010	VT2+2.6-6	3
315	S5-OA4-001-960	BASE,INCL T(S) ASS'Y	1	504	87-743-073-410	SCREW,TAP 2.6-6	3
316	S5-OA4-001-970	P5-3 ARM ASS'Y	1	505	S1-0A1-268-040	SCREW,WASHER(A)M2.6-8	3
317	S5-OA4-002-050	PINCH ROLLER BLOCK	1	506	S1-0B1-264-040	SCREW,WASHER(B)M2.6-4	1
318	S5-OA4-001-750	TENSION ARM ASS'Y	1	507	87-261-035-410	SCREW,PAN M2-6	3
319	S5-OA4-001-760	TENSION BAND ASS'Y	1	508	87-261-032-410	SCREW,PAN M2-3	2
320	S5-OA4-001-780	PINCH ROLLER LEVER ASS'Y	1	509	87-258-091-010	U+M3-3	2
321	S5-OA6-001-820	BRAKE T ASS'Y	1	510	S2-Q31-54C-5N0	PW,3.1-5.4-0.25	1
322	S5-OA6-001-830	CAP BRAKE ARM ASS'Y	1	511	S2-P26-600-5N0	PW(CUT)2.6-6-0.5	3
323	S5-OA9-002-130	LINK ASS'Y	1	512	S2-Q26-471-3N0	PW 2.6-4.7-0.13	3
324	S5-OA9-002-160	LINK LEVER ASS'Y	1	513	S2-P18-450-5N0	PW(CUT)1.8-4.5-0.5	1
325	S5-OP2-002-610	LEVER,CLUTCH	1	514	S3-ETW-300-000	E-RING 3	2
326	S5-OP2-002-620	RING,CLUTCH	1	515	S1-0A1-235-040	SEMS A M2.3-5	2
327	S5-OP2-002-630	GEAR,CLUTCH	1	CP101	----	CONN,PWB SIDE	1
328	S5-OP2-002-710	REEL,S	1	CP102	----	CONN,PWB SIDE 173979-2	1
329	S5-OP2-002-730	STOPPER,REEL S	1	H5001	S5-23D-910-340	HEAD,AC	1
330	S5-OP2-002-740	SPACER,LINK LEVER	1	H5002	S5-43D-020-130	HEAD,FE	1
331	S5-OP3-001-780	GEAR,MAIN LOADING	1	M101	S5-96P-780-010	MOTOR(LOADING)	1
332	S5-OP3-001-790	GEAR,LOADING S	1	M2001	S5-94J-980-080	CAPSTAN DD UNIT EP15BC	1
333	S5-OP3-001-800	GEAR,LOADING T	1	M2003	S5-89V-110-070	MICRO MOTOR	1
334	S5-OP3-001-860	HOLDER,LOADING GEAR	1	PCB550	----	DECK PCB ASS'Y VE8851	1
335	S5-OP4-004-720	ADJUST,TENSION	1	Q101	S0-007-003-200	PHOTO,TR RPT-38PB113	1
336	S5-OP4-004-920	HOLDER,TENSION	1	Q102	S0-007-003-200	PHOTO,TR RPT-38PB113	1
337	S5-OP4-004-900	LEVER,TENSION	1	UN4001	S5-500-2A5-000	CYLINDER UNIT ASS'Y A55002A50C	1
338	S5-OP4-004-750	COVER,P4	1				
339	S5-OP6-005-430	GEAR,JOINT	1				
340	S5-OP6-005-440	GEAR,MIDDLE	1				
341	S5-OP6-005-450	CAM,MAIN	1				
342	S5-OP6-005-460	CAM,P5	1				
343	S5-OP6-005-650	CAM,PINCH ROLLER	1				
344	S5-OP6-005-480	ROD,MAIN	1				
345	S5-OP7-000-350	REFLECTOR,LED	1				
346	S5-OP8-003-180	SPR,LOADING GEAR	2				
347	S5-OP8-003-190	SPR,P5	1				
348	S5-OP8-003-210	SPR,BRAKE T	1				
349	S5-OP8-003-220	SPR,TENSION	1				
350	S5-OP8-003-230	SPR,CAP BRAKE	1				
351	S5-OP8-003-420	SPRING,LOCKER(S)	2				
352	S5-OP8-003-260	SPR,LINK	1				
353	S5-OP8-003-280	SPR,DAMPER	1				
354	S5-OP8-003-300	SPR,RING	1				
355	S5-OP8-003-320	SPR,S-S BRAKE	1				
356	S5-OP9-006-800	OPENER,CASS	1				
357	S5-OP9-006-830	CASS SIDE L	1				
358	S5-OP9-006-840	CASS SIDE R	1				
359	S5-OP9-007-090	TAPE GUIDE L(P,R)	1				

ELECTRICAL REPLACEMENT PARTS LIST

REF.NO.	PART NO.	DESCRIPTION	REF.NO.	PART NO.	DESCRIPTION
SYSCON PCB ASS'Y			*** CAPACITORS ***		
		*** RESISTORS ***	C4071	87-015-695-080	CAP,E 1-50V
R360	S3-118-A01-0J0	RES,M/O 1-2W	C4073	87-010-549-010	CAP,E 47-6.3V
R640	S4-X5T-647-2F0	RES,M 4.7K-1/6W	C4076	87-015-677-010	CAP,E 100-6.3V
△R1005	S6-150-12R-7J0	RES,FUSE 2.7-1W	C4078	87-010-549-010	CAP,E 47-6.3V
R4031	S4-X5T-612-2F0	RES,MF 1.2K-1/6W	C4209	87-015-685-040	CAP,E 10UF-25V
		*** CAPACITORS ***	C4211	87-010-235-080	CAP,E 470-16V
			C4220	87-010-263-010	CAP,E 100-10V
					*** DIODES ***
C352	87-015-695-080	CAP,E 1-50V	D601	S9-7U0-9R1-1B0	ZENER,MTZJ9.1B
C354	87-016-588-080	CAP,E 2200-25V	D603	87-020-465-010	DIODE,1SS133T
C355	S0-2NT-52R-2M0	CAP,E 2.2-50V	D604	87-020-465-010	DIODE,1SS133T
C356	87-015-075-040	CAP,E 10-16V	D605	S2-8T1-1ES-N10	DIODE,11E1N-TA1B2
C357	87-010-560-080	CAP,E 10-50V	D622	S2-8T1-1E1-N10	DIODE,11E1N-TA1B2
C359	87-010-067-010	CAP,E 0.1-50V	D1001	S2-8T1-1E1-N10	DIODE,11E1N-TA1B2
C601	87-015-695-080	CAP,E 1-50V	D1003	S0-106-000-600	LED,SID1050CM
C605	87-010-402-080	CAP,E 2.2-50V	D1004	S9-2T1-120-B00	ZENER,RD12FB-T7
C611	87-010-560-080	CAP,E 10-50V	D1005	S2-8T1-1E1-N10	DIODE,11E1N-TA1B2
C617	87-010-400-080	CAP,E 0.47-50V	D1006	S2-3U1-003-A30	DIODE,SB10-03A3
C618	87-015-677-010	CAP,E 100-6.3V	D1007	S2-8T1-1ES-N10	DIODE,11ES1N-TA1B2
C621	87-010-550-080	CAP,E 1000-6.3V	D1008	S2-8T1-1E1-N10	DIODE,11E1N-TA1B2
C623	87-015-695-080	CAP,E 1-50V	D1010	S2-LXE-658-000	DIODE,1N4005E-G23
C624	87-015-695-080	CAP,E 1-50V	D1011	S2-3U1-003-A30	DIODE,SB10-03A3
C625	87-010-071-080	CAP,E 1-50V	D1014	S9-7U0-5R1-1B0	ZENER,MTZJ5.1B
C626	87-015-075-040	CAP,E 10-16V	D1017	87-020-465-010	DIODE,1SS133T
C633	87-010-112-080	CAP,E 100-16V	D1018	S2-8TE-QS0-400	DIODE,11EQS04N-TA
C634	87-010-380-080	CAP,E 47-16V	D4001	87-020-465-010	DIODE,1SS133T
C638	87-010-235-080	CAP,E 470-16V	D4004	87-017-931-010	ZENER,MTZJ5.6B
C643	87-010-400-080	CAP,E 0.47-50V	D4201	87-017-931-010	ZENER,MTZJ5.6B
C645	87-010-112-080	CAP,E 100-16V	D4202	S2-3U1-003-A30	DIODE,SB10-03A3
C650	87-015-695-080	CAP,E 1-50V	D4207	S3-Z68-V10-000	ZENER,MTZJ6.8B
C652	87-010-400-080	CAP,E 0.47-50V			*** ICS ***
C654	87-010-545-040	CAP,E 0.22-50V	△IC352	S0-FSP-752-300	IC,AN7523
C656	87-A10-189-040	CAP,E 220-10V	IC601	87-A20-790-010	IC,KIA7806P
C659	87-010-402-080	CAP,E 2.2-50V	△IC604	S0-3FE-814-B00	IC,LA76814BM-MPB
C660	87-010-400-080	CAP,E 0.47-50V	IC1001	S5-6F5-704-1A0	IC,QEC7041A
C661	87-010-375-010	CAP,E 330-10V	IC1002	S9-UJ0-T60-0H0	IC,PST600H
C668	87-010-402-080	CAP,E 2.2-50V	△IC1003	S0-7SQ-955-AN0	IC,BA6955AN
C683	87-010-685-080	CAP,E 330-16V	IC1099	S5-505-1C0-150	IC,S-24C04BDP-LA
△C1001	87-010-135-010	CAP,E 100-25V	IC4001	S0-3F3-711-700	IC,LA71170M-MPB
C1003	87-010-550-080	CAP,E 330-10V			*** TRANSISTORS ***
C1004	S0-2LT-422-1M0	CAP,E 220-35V	Q352	89-324-122-080	TR,2SC2412KT
C1015	87-015-680-010	CAP,E 47-10V	Q602	89-110-372-080	TR,2SA1037AK
C1016	87-016-053-080	CAP,E 22-16V	Q605	84-LB2-698-080	TR,2SA733(C)-T
C1018	87-010-404-080	CAP,E 4.7-50V	Q607	87-026-236-080	TR,DTC124EK
C1020	87-015-075-040	CAP,E 10-16V	Q608	89-110-372-080	TR,2SA1037AK
C1021	87-015-683-080	CAP,E 33-16V	Q1001	8Z-JU1-603-010	PHOTO,COUPLER GP1S566
C1032	87-016-088-040	CAP,E 220-6.3V	Q1002	89-324-122-080	TR,2SC2412KT
C1037	87-016-088-040	CAP,E 220-6.3V	Q1003	S0-02G-004-900	PHOTO,COUPLER GP1S94L
C1042	87-010-071-080	CAP,E 1-50V	Q1004	87-026-236-080	TR,DTC124EK
C1043	87-010-560-080	CAP,E 10-50V	Q1005	8Z-JU1-603-010	PHOTO,COUPLER GP1S566
C1056	87-010-371-080	CAP,E 470-6.3V	Q1006	89-324-122-080	TR,2SC2412KT
C1058	87-010-079-080	CAP,E 100-6.3V	Q1008	87-026-236-080	TR,DTC124EK
C4006	87-010-370-080	CAP,E 330-6.3V	Q1009	S0-02G-004-900	PHOTO,COUPLER GP1S94L
C4007	87-015-677-010	CAP,E 100-6.3V	Q1010	87-026-227-080	TR,DTA114E
C4012	87-010-404-080	CAP,E 4.7-50V	Q1011	SD-70D-239-600	TR,2SD2396(J,K)
C4015	S5-0HU-047-0M0	CAP,E 47-6.3V	Q1012	89-324-122-080	TR,2SC2412KT
C4016	87-015-695-080	CAP,E 1-50V	Q1014	87-026-236-080	TR,DTC124EK
C4023	87-015-683-080	CAP,E 33-16V	Q1015	89-324-122-080	TR,2SC2412KT
C4025	87-015-075-040	CAP,E 10-16V	Q1016	89-324-122-080	TR,2SC2412KT
C4027	87-016-053-080	CAP,E 22-16V	Q1017	89-324-122-080	TR,2SC2412KT
C4028	87-010-404-080	CAP,E 4.7-50V	Q1018	89-324-122-080	TR,2SC2412KT
C4035	87-010-402-080	CAP,E 2.2-50V	△Q1019	SB-300-113-4R0	TR,2SB1134R
C4039	87-015-695-080	CAP,E 1-50V	Q1023	89-324-122-080	TR,2SC2412KT
C4040	87-015-695-080	CAP,E 1-50V	Q1024	87-026-287-080	TR,DTC143EKAT146
C4041	87-015-677-010	CAP,E 100-6.3V	Q4001	SC-3T0-333-100	TR,2SC3331(S,T,U)-A
C4046	87-015-695-080	CAP,E 1-50V	Q4002	SC-3T0-333-100	TR,2SC3331(S,T,U)-A
C4048	87-010-403-080	CAP,E 3.3-50V	Q4003	87-026-228-080	TR,DTA124EK
C4051	87-015-695-080	CAP,E 1-50V	Q4004	89-324-122-080	TR,2SC2412KT
C4055	87-010-549-010	CAP,E 47-6.3V	Q4005	89-113-187-080	TR,2SA1318(S,T)
C4058	87-015-695-080	CAP,E 1-50V	Q4006	89-313-172-010	TR,2SC1317
C4062	87-015-075-040	CAP,E 10-16V			
C4063	87-015-695-080	CAP,E 1-50V			
C4067	87-015-683-080	CAP,E 33-16V			
C4068	87-010-403-080	CAP,E 3.3-50V			
C4070	87-015-677-010	CAP,E 100-6.3V			

ELECTRICAL REPLACEMENT PARTS LIST

REF.NO.	PART NO.	DESCRIPTION	REF.NO.	PART NO.	DESCRIPTION
*** TRANSISTORS ***			*** TUNER ***		
Q4007	89-324-122-080	TR,2SC2412KT	△TU601	S1-45K-000-500	TUNER,UHF-VHF TECC1040PG31
Q4009	89-324-122-080	TR,2SC2412KT			
Q4010	89-324-122-080	TR,2SC2412KT			*** OTHERS ***
Q4011	89-110-372-080	TR,2SA1037AK			
Q4012	89-110-372-080	TR,2SA1037AK	CD604	S6-CH0-100-5A0	CORD,CONN CH01005A
Q4013	87-026-239-080	DTC114TKAT14	CD810	S6-CH2-A01-4A0	CORD,CONN CH2A014A
Q4201	87-026-235-010	TR,DTC114EK	CD820	S6-CH2-B02-7A0	CORD,CONN CH2B027A
Q4202	87-026-235-010	TR,DTC114EK	CD850	S6-CH2-508-0A0	CORD CONN CH25080A
Q4204	87-026-235-010	TR,DTC114EK	CP601	S6-CH2-207-1A0	CORD,CONN CH22071A
Q4205	87-026-235-010	TR,DTC114EK	CP1002	S6-CH2-207-6A0	CORD CONN CH22076A
Q4206	87-026-235-010	TR,DTC114EK			OPERATION PCB ASS'Y
Q4207	87-026-235-010	TR,DTC114EK			
Q4210	89-110-372-080	TR,2SA1037AK			*** CAPACITORS ***
Q4212	89-110-372-080	TR,2SA1037AK			
*** COILS ***			C353	87-010-380-080	CAP,E 47-16V
B602	S2-4AT-036-550	CORE,BEADS BL01RN1-A63T6	C354	87-010-380-080	CAP,E 47-16V
B4003	S2-4AT-036-550	CORE,BEADS BL01RN1-A63T6	C755	87-016-088-040	CAP,E 220-6.3V
L102	S2-A6A-8A0-A10	CORE,FERRITE HF57T18.5*10*10			*** DIODES ***
L602	87-003-146-010	COIL,15UH	D791	S0-21M-2Q1-200	LED,EQ-552-F1T
L604	87-003-039-080	COIL,0.56UH	D792	S0-21M-2Q1-200	LED,EQ-552-F1T
L605	87-003-152-010	COIL,100UH	D793	S0-21M-2Q1-200	LED,EQ-552-F1T
L607	87-003-152-010	COIL,100UH	D795	S0-21M-5Q1-500	LED,EM-553-F1T
L608	S2-167-D10-1K0	COIL,100UH	D796	S0-21M-5Q1-500	LED,EM-553-F1T
L610	S3-360-203-880	COIL,V IFT	D797	S0-21M-2Q1-200	LED,EQ-552-F1T
L611	87-005-096-010	COIL,100UH			*** COILS ***
L613	S2-16A-647-0K0	COIL,47UH	B701	S2-4AT-036-550	CORE,BEADS BL01RN1-A63T6
L615	S2-167-D27-0K0	COIL,27UH			
L1001	87-A50-040-010	COIL,2.2UH	L004	S2-A6A-8A0-A10	CORE,FERRITE HF57T18.5*10*10
L4001	S3-262-300-380	COIL,TRAP 2623003			*** JACKS ***
L4002	S2-167-D10-1K0	COIL,100UH	△J351	S6-021-310-120	JACK,RCA 3.5 HSJ2630-0100
L4003	S3-162-600-7S0	COIL,BIAS OSC	J701	S6-021-010-200	JACK,RCA
L4004	S2-167-D10-1K0	COIL,100UH			*** SWITCHES ***
L4005	87-005-096-010	COIL,100UH	SW750	S5-042-01T-310	SW,TACT SKHVBED10
L4006	87-005-096-010	COIL,100UH	SW751	S5-042-01T-310	SW,TACT SKHVBED10
L4007	S2-16A-656-0K0	COIL,56UH	SW791	S5-042-01T-310	SW,TACT SKHVBED10
L4008	S2-16A-612-1K0	COIL,120UH	SW792	S5-042-01T-310	SW,TACT SKHVBED10
L4009	87-005-096-010	COIL,100UH	SW793	S5-042-01T-310	SW,TACT SKHVBED10
L4011	S2-167-D10-1K0	COIL,100UH	SW794	S5-042-01T-310	SW,TACT SKHVBED10
L4012	S2-167-D10-1K0	COIL,100UH	SW795	S5-042-01T-310	SW,TACT SKHVBED10
L4014	87-003-150-010	COIL,68UH	SW796	S5-042-01T-310	SW,TACT SKHVBED10
L4015	87-005-096-010	COIL,100UH	SW797	S5-042-01T-310	SW,TACT SKHVBED10
L4205	87-003-152-010	COIL,100UH	SW798	S5-042-01T-310	SW,TACT SKHVBED10
		*** JACK ***	SW799	S5-042-01T-310	SW,TACT SKHVBED10
J4201	S6-3P0-000-640	PLATE,JACK T6582-ABCC			*** OTHERS ***
		*** SWITCH ***	CD351	S6-CH2-708-6A0	CORD,CONN CH27086A
SW1001	S5-082-210-010	SW,LEAF	CD750	S6-CH2-B02-6A0	CORD,CONN CH2B026A
		*** CONNECTORS ***	OS753	S7-7Q0-000-170	REMOTE RECEIV
CP351	S6-9E2-701-290	CONN PWB SIDE			MAIN PCB ASS'Y
CP354	S6-9E2-B01-290	CONN,PWB SIDE			*** RESISTORS ***
CP603	S6-9E2-601-290	CONN,PWB SIDE			
CP1004	S6-972-805-900	CONN PWB SIDE	△R439	S4-X5T-422-3F0	RES,MF 22K-1/4W
CP1005	S6-9R7-500-280	CONN,PWB SIDE 52045-0545	△R440	S4-X5T-482-2F0	RES,M 8.2K-1/4W
CP1006	S6-9R7-400-280	CONN,52045-0445	△R441	87-025-571-080	RES,M 100K-1/4W
CP4001	S6-972-906-200	CONN PWB SIDE	△R442	87-025-459-080	RES,M 15K-1/4W
CP4004	S6-971-203-200	CONN	△R443	87-025-297-080	RES,M/F 4.7K-1/4W
		*** FILTER ***	△R444	S4-X5T-422-3F0	RES,MF 22K-1/4W
CF601	S0-2E2-45R-710	FLTR,SAW M1958M	△R447	87-A00-100-060	RES,FUSE 68-1/2W
		*** CRYSTAL & CERAMIC OSCILLATORS ***	△R448	SF-F01-02J-B10	RES,M 1K-1W
X604	S0-OCT-3R5-050	X'TAL,HC-49/C	△R449	S5-X2C-E68-2J0	RES,CEMENT 6.8K-7W
X1001	S0-OCT-012-070	X'TAL,HC-49/U-S	△R450	S6-558-14R-7J0	RES,FUSE 4.7-1W
X1002	S0-0D3-2R8-010	X'TAL,32.768K	△R501	S5-X2C-E1R-2J0	RES,CEMENT 1.2-7W
X4001	S0-OCT-3R5-040	X'TAL,HC-49/C			

ELECTRICAL REPLACEMENT PARTS LIST

REF.NO.	PART NO.	DESCRIPTION	REF.NO.	PART NO.	DESCRIPTION
*** RESISTORS ***			*** DIODES ***		
△ R505	87-022-448-090	RES,M/O 22K-3W	D528	S9-4TA-6RA-130	ZENER,HZ6A3L TD
△ R510	S3-U28-B1R-2J0	RES,M 1.2-3W	D529	87-020-465-010	DIODE,1SS133T
△ R512	S3-X18-127-3J0	RES,M 27K	D530	S2-8T1-1E1-N10	DIODE,11E1N-TA1B2
△ R517	S3-X28-AR3-3J0	RES,M 0.33-2W	D531	S2-8T1-1E1-N10	DIODE,11E1N-TA1B2
△ R529	S4-X5T-627-2F0	RES,M 2.7K-1/6W	D532	S2-8T1-1E1-N10	DIODE,11E1N-TA1B2
△ R542	87-A00-091-080	RES,M 0.15-1W	D534	S2-8T1-1E1-N10	DIODE,11E1N-TA1B2
*** CAPACITORS ***			D535	S2-8T1-1ES-N10	DIODE,11ES1N-TA1B2
			D536	S2-8T1-1ES-N10	DIODE,11ES1N-TA1B2
C401	87-016-636-080	CAP,E 4.7-50V	△ IC506	S0-025-004-800	PHOTO,COUPLER TLP621
C403	87-010-047-010	CAP,E 100-50V	△ TH501	SF-20C-3R0-Q00	DEGAUSS ELEMENT PTH451C3R0Q11
C406	S5-EZT-410-1M0	CAP,E 100-35V			*** ICS ***
△ C407	S6-2I0-312-2M0	CAP,E 1200-25V			
C412	S0-JTB-05N-2K0	CAP,390P-500V B	△ IC401	87-A20-128-010	IC,LA7840
C417	S0-JTB-05S-2K0	CAP,CER 560PF-500V	△ IC501	S2-BT0-661-200	IC,STR-F6612
C418	S5-EZT-B01-0M0	CAP,E 1-160V	△ IC502	87-A20-790-010	IC,KIA7806P
△ C421	S5-EZ0-410-2M0	CAP,E 1000-35V	△ IC503	S0-GA9-09R-D00	IC,PQ09RD08
C422	S5-EZT-D01-0M0	CAP,E 1-250V	△ IC504	87-A20-525-010	IC,KIA7812PI
C423	S4-11F-333-4J0	CAP,MPP 0.33-250V	IC505	87-A20-790-010	IC,KIA7806P
△ C424	SA-LRB-22J-010	CAP,MPP 0.0082-1.6KV			*** TRANSISTORS ***
△ C425	S0-34B-N7W-2K0	CAP,CER 820P-2KV BP	△ Q405	SC-3T0-227-100	TR,2SC2271(D,E)-AE
C429	87-012-386-080	CAP,CER 470PF-2KV	△ Q406	SD-UQ0-259-900	TR,2SD2599
△ C431	87-016-373-080	CAP,E 10-250V	△ Q501	SC-3T0-290-900	TR,2SC2909
△ C433	S5-EZT-822-0M0	CAP,E 22-100V	△ Q502	SA-3T1-371-A00	TR,2SA1371
C438	87-010-977-010	CAP,CER 680PF-500V	△ Q503	SC-300-416-000	TR,2SC4160-OEC
C450	S0-34B-N71-3K0	CAP,CER 0.001-2KV	△ Q504	89-318-154-080	TR,2SC1815Y
C505	S2-122-B22-4M0	CAP,0.22-250V E	Q506	87-026-464-080	TR,DTC114TS
△ C507	S5-2SF-C47-1M0	CAP,E 470-200V	Q507	89-309-458-010	TR,2SC945(C)
△ C510	S5-EZT-822-0M0	CAP,E 22-100V	Q513	SN-YTB-030-010	TR,DTC114E
△ C511	S5-EZT-247-1M0	CAP,E 470-16V	Q520	87-026-464-080	TR,DTC114TS
C514	S0-1BB-P7K-3K0	CAP,0.0027-2KV	Q521	87-026-464-080	TR,DTC114TS
C516	87-012-376-010	CAP,CER 470PF-500V			*** COILS ***
C517	S0-34B-N7W-2K0	CAP,CER 820P-2KV BP	B502	S2-4AT-034-820	CORE,BEADS
C518	87-012-376-010	CAP,CER 470PF-500V	B504	S2-4AT-036-550	CORE,BEADS BL01RN1-A63T6
C519	87-012-376-010	CAP,CER 470PF-500V	B505	S2-4DT-035-810	CORE,BEADS LFP3A-M3R2TA
C520	S6-2FT-247-1M0	CAP,E 470-16V			
△ C521	S5-3J0-B22-1M0	CAP,E 220-160V	L401	87-003-143-010	COIL,4.7MH
△ C523	S0-2LT-447-1M0	CAP,E 470-35V	L402	S2-210-000-130	COIL,LINEA ELH5L4112
△ C524	S5-EZT-347-1M0	CAP,E 470-25V	△ L501	S2-9X0-000-360	FILTER,SS28V-15125
△ C526	S5-EZT-147-1M0	CAP,E 470-10V			
C527	S0-34B-N7Q-2K0	CAP,CER 470P-2KV BP	T401	S3-305-Y00-2S0	TRANS,H DRIVE 305Y002S
△ C531	87-010-271-080	CAP,E 1000-16V			*** TRANSFORMERS ***
△ C532	S5-EZT-247-1M0	CAP,E 470-16V	△ FB401	S4-321-301-2R0	TRANS,FLYBACK 3213012R
△ C536	S5-EZT-447-1M0	CAP,E 470-35V	△ T501	S4-813-505-0W0	TRANS,SW 8135050W
△ C537	S5-EZT-54R-7M0	CAP,E 4.7-50V	△ T502	S4-013-600-160	TRANS,POWER AC 0136001
△ C538	S5-EZT-147-1M0	CAP,E 470-10V			*** VARIABLE RESISTORS ***
△ C540	S5-EZT-B10-0M0	CAP,E 10-160V	VR502	S1-263-L2B-TC0	SFR,RH063MCN2R07
△ C541	S6-2DF-B47-0M0	CAP,E 47-160V			*** CONNECTORS ***
*** DIODES ***			△ CP401	S6-9X4-500-290	CONN PWB SIDE B05B-DVS
D401	S2-8T1-1E1-N10	DIODE,11E1N-TA1B2	△ CP501	S6-973-200-390	CORD UX CONNECTOR
△ D408	87-020-407-010	ZENER,HZ27-1L TD	CP810	S6-9E2-A01-290	CONN,PWB SIDE
△ D409	87-027-556-080	ZENER,HZ11B3L TD	CP820	S6-9E2-B01-290	CONN,PWB SIDE
△ D411	S2-LTP-G06-J00	DIODE,RMPG06J			*** FUSES ***
△ D412	S2-LTP-G06-J00	DIODE,RMPG06J	CP803A	S6-7R1-050-190	HOLDER,WIRE 51052-0500
△ D413	S2-LTP-G06-J00	DIODE,RMPG06J	△ F501	S8-1PA-050-030	FUSE,233005-MB000
△ D501	S2-BTR-M11-C00	DIODE,RM11C	F502	S8-0PA-2R5-010	FUSE,23302.5-MB00
△ D502	S2-BTR-M11-C00	DIODE,RM11C	FH501	S6-710-T00-060	HOLDER,FUSE EYF-52B
△ D503	S2-BTR-M11-C00	DIODE,RM11C	FH502	S6-710-T00-060	HOLDER,FUSE EYF-52B
△ D504	S2-BTR-M11-C00	DIODE,RM11C	FH503	S6-710-T00-060	HOLDER,FUSE EYF-52B
△ D505	S2-8T2-1DQ-N90	DIODE,21DQ09N-TA2B	FH504	S6-710-T00-060	HOLDER,FUSE EYF-52B
D506	S2-LTP-G06-J00	DIODE,RMPG06J			
△ D508	S2-8T2-1DQ-N90	DIODE,21DQ09N-TA2B			
△ D509	S2-8T2-1DQ-N90	DIODE,21DQ09N-TA2B			
△ D510	S2-BTR-U2A-M00	DIODE,RU2AM V1			
△ D512	S2-8T2-1DQ-N90	DIODE,21DQ09N-TA2B			
△ D515	87-027-661-010	ZENER,HZ30-1L TD			
D516	87-020-465-010	DIODE,1SS133T			
D518	87-020-465-010	DIODE,1SS133T			
△ D519	S2-8T2-1DQ-N90	DIODE,21DQ09N-TA2B			
D521	87-020-465-010	DIODE,1SS133T			
△ D523	87-020-465-010	DIODE,1SS133T			
D524	S2-8T1-1E1-N10	DIODE,11E1N-TA1B2			
D527	S2-8T1-1E1-N10	DIODE,11E1N-TA1B2			

ELECTRICAL REPLACEMENT PARTS LIST

REF.NO.	PART NO.	DESCRIPTION
		*** RELAY ***
△RY501	S5-60Q-102-010	RELAY,SDT-S-109LMR
		*** OTHERS ***
EL002	S2-412-030-1A0	EYE LET XRY20X30BD
△ICP502	S8-3PC-040-020	MICRO FUSE 251004
△ICP503	S8-3PC-050-020	MICRO FUSE,251005
△ICP504	S8-3PC-050-020	MICRO FUSE,251005
△ICP505	S8-3PC-030-020	MICRO FUSE,251003
		CRT PCB ASS'Y
		*** RESISTORS ***
△R802	87-A00-164-090	RES,M 12K-2W
△R805	87-A00-164-090	RES,M 12K-2W
△R810	87-A00-164-090	RES,M 12K-2W
		*** CAPACITORS ***
C801	S0-34B-N71-3K0	CAP,CER 0.001-2KV
C820	87-016-322-080	CAP,E 1-250V
		*** TRANSISTORS ***
△Q804	SC-3F0-421-700	TR,2SC4217(D,E)
△Q805	SC-3F0-421-700	TR,2SC4217(D,E)
△Q806	SC-3F0-421-700	TR,2SC4217(D,E)
		*** CONNECTOR ***
CP850	S6-9E2-501-290	CONN,PWB SIDE
		*** FUSE ***
CP803B	S6-7R1-050-190	HOLDER,WIRE 51052-0500
		*** CRT SOCKET ***
△J801	S6-6X1-200-140	SOCKET,CRT HPS320
		AND OTHERS
		*** CONNECTOR ***
CD801	S6-8M8-202-5A0	CORD CONN 8M82025
		*** OTHER ***
CD802	S6-CH0-101-0A0	CORD,CONN CH01010A
		*** COIL ***
△L503	S2-8R1-400-230	COIL,DEGAUSS 8R140023
		*** AC CORD ***
△CD501	S2-0R6-149-180	CORD,AC 0R614918
		*** OTHERS ***
CD353	S6-CH1-243-7A0	CORD,CONN CH12437A
CD354	S6-CH1-243-8A0	CORD,CONN CH12438A
△SP351	S7-0C5-330-080	SPEAKER,810-47-171
△SP352	S7-0C5-330-080	SPEAKER,810-47-171
△V801	S9-8Y1-404-970	CRT W/DY A34JXV70X28N45

アイワ株式会社 〒110-8710 東京都台東区池之端1-2-11 ☎03(3827)3111 (代表)
AIWA CO.,LTD. 2-11, IKENOHATA 1-CHOME, TAITO-KU, TOKYO 110, JAPAN TEL:03 (3827) 3111